



⚠ Read this manual carefully before operating this vehicle.

OWNER'S MANUAL

EXFITER

T150

B15-F8199-E1

 **Read this manual carefully before operating this vehicle. This manual should stay with this vehicle if it is sold.**

Welcome to the Yamaha world of motorcycling!

As the owner of the T150, you are benefiting from Yamaha's vast experience and newest technology regarding the design and manufacture of high-quality products, which have earned Yamaha a reputation for dependability.

Please take the time to read this manual thoroughly, so as to enjoy all advantages of your T150. The Owner's Manual does not only instruct you in how to operate, inspect and maintain your motorcycle, but also in how to safeguard yourself and others from trouble and injury.

In addition, the many tips given in this manual will help keep your motorcycle in the best possible condition. If you have any further questions, do not hesitate to contact your Yamaha dealer.

The Yamaha team wishes you many safe and pleasant rides. So, remember to put safety first!

Yamaha continually seeks advancements in product design and quality. Therefore, while this manual contains the most current product information available at the time of printing, there may be minor discrepancies between your motorcycle and this manual. If there is any question concerning this manual, please consult a Yamaha dealer.



 **WARNING**

Please read this manual carefully and completely before operating this motorcycle.

IMPORTANT MANUAL INFORMATION

EAU10134

Particularly important information is distinguished in this manual by the following notations:

	This is the safety alert symbol. It is used to alert you to potential personal injury hazards. Obey all safety messages that follow this symbol to avoid possible injury or death.
	A WARNING indicates a hazardous situation which, if not avoided, could result in death or serious injury.
	A NOTICE indicates special precautions that must be taken to avoid damage to the vehicle or other property.
TIP	A TIP provides key information to make procedures easier or clearer.

*Product and specifications are subject to change without notice.

IMPORTANT MANUAL INFORMATION

EALV0011

**T150
OWNER'S MANUAL
©2017 by Yamaha Motor Vietnam Co.,
Ltd.
1st edition, July 2017
All rights reserved.
Any reprinting or unauthorized use
without the written permission of
Yamaha Motor Vietnam Co., Ltd.
is expressly prohibited.
Printed in Vietnam.**

TABLE OF CONTENTS

LOCATION OF IMPORTANT

LABELS 1-1

SAFETY INFORMATION

Further safe-riding points 2-5

Helmets 2-6

DESCRIPTION

Left view 3-1

Right view 3-2

Controls and instruments 3-3

INSTRUMENT AND CONTROL

FUNCTIONS 4-1

Main switch/steering lock 4-1

Keyhole cover 4-2

Indicator lights and warning
lights 4-3

Multi-function meter unit 4-4

Handlebar switches 4-7

Clutch lever 4-8

Shift pedal 4-8

Brake lever 4-8

Brake pedal 4-9

Fuel tank cap 4-9

Fuel 4-10

Catalytic converter 4-11

Kickstarter 4-12

Seat 4-12

Helmet holders 4-13

Storage compartment 4-13

Sidestand 4-14

Starting circuit cut-off system 4-14

FOR YOUR SAFETY –

PRE-OPERATION CHECKS 5-1

OPERATION AND IMPORTANT

RIDING POINTS 6-1

..... 6-1

Starting the engine 6-2

Shifting 6-2

Tips for reducing fuel
consumption 6-3

Engine break-in 6-3

Parking 6-4

General note 6-5

PERIODIC MAINTENANCE AND

ADJUSTMENT 7-1

Owner's tool kit 7-1

Periodic maintenance chart for
the emission control system 7-2

General maintenance and
lubrication chart 7-3

Removing and installing the
cowling and panels 7-7

Checking the spark plug 7-8

Engine oil and oil filter element 7-10

Coolant 7-12

Cleaning the air filter element 7-14

Adjusting the engine idling

speed 7-15

Adjusting the throttle grip

free play 7-16

Valve clearance 7-16

Tires 7-17

Cast wheels 7-18

Adjusting the clutch lever

free play 7-19

Checking the brake lever

free play 7-20

Checking the shift pedal 7-20

Brake light switches 7-21

Checking the front and rear

brake pads 7-21

Checking the brake fluid level 7-22

Changing the brake fluid 7-23

Drive chain slack 7-23

Cleaning and lubricating the

drive chain 7-25

Checking and lubricating the

cables 7-25

Checking and lubricating the

throttle grip and cable 7-25

Checking and lubricating the

brake and clutch levers 7-26

Checking and lubricating the

brake pedal 7-26

Checking and lubricating the

centerstand and sidestand 7-27

TABLE OF CONTENTS

Lubricating the swingarm pivots	7-27	INDEX	11-1
Checking the front fork.....	7-28		
Checking the steering	7-28		
Checking the wheel bearings	7-29		
Battery	7-29		
Replacing the fuses.....	7-30		
Replacing the headlight bulb.....	7-31		
Auxiliary light	7-32		
Tail/brake light.....	7-32		
Replacing a front turn signal light bulb	7-33		
Replacing a rear turn signal light bulb	7-33		
Replacing the license plate light bulb	7-34		
Front wheel.....	7-35		
Rear wheel.....	7-35		
Troubleshooting	7-37		
Troubleshooting charts	7-38		
MOTORCYCLE CARE AND STORAGE	8-1		
Matte color caution	8-1		
Care.....	8-1		
Storage.....	8-3		
SPECIFICATIONS	9-1		
CONSUMER INFORMATION	10-1		
Identification numbers.....	10-1		

LOCATION OF IMPORTANT LABELS

EAU10385

1

Read and understand all of the labels on your vehicle. They contain important information for safe and proper operation of your vehicle. Never remove any labels from your vehicle. If a label becomes difficult to read or comes off, a replacement label is available from your Yamaha dealer.

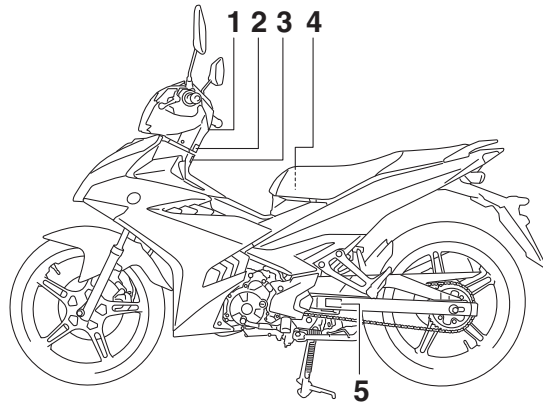

1



2



3



4



5

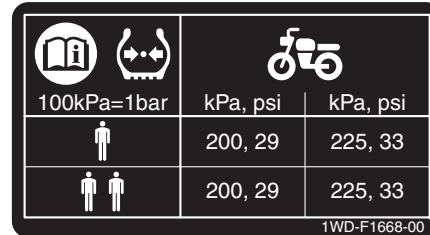

EAU1028B

2

Be a Responsible Owner

As the vehicle's owner, you are responsible for the safe and proper operation of your motorcycle.

Motorcycles are single-track vehicles. Their safe use and operation are dependent upon the use of proper riding techniques as well as the expertise of the operator. Every operator should know the following requirements before riding this motorcycle.

He or she should:

- Obtain thorough instructions from a competent source on all aspects of motorcycle operation.
- Observe the warnings and maintenance requirements in this Owner's Manual.
- Obtain qualified training in safe and proper riding techniques.
- Obtain professional technical service as indicated in this Owner's Manual and/or when made necessary by mechanical conditions.

- Never operate a motorcycle without proper training or instruction. Take a training course. Beginners should receive training from a certified instructor. Contact an authorized motorcycle dealer to find out about the training courses nearest you.

Safe Riding

Perform the pre-operation checks each time you use the vehicle to make sure it is in safe operating condition. Failure to inspect or maintain the vehicle properly increases the possibility of an accident or equipment damage. See page 5-1 for a list of pre-operation checks.

- This motorcycle is designed to carry the operator and a passenger.
- The failure of motorists to detect and recognize motorcycles in traffic is the predominating cause of automobile/motorcycle accidents. Many accidents have been caused by an automobile driver who did not see the motorcycle. Making yourself conspicuous ap-

pears to be very effective in reducing the chance of this type of accident.

Therefore:

- Wear a brightly colored jacket.
- Use extra caution when you are approaching and passing through intersections, since intersections are the most likely places for motorcycle accidents to occur.
- Ride where other motorists can see you. Avoid riding in another motorist's blind spot.
- Never maintain a motorcycle without proper knowledge. Contact an authorized motorcycle dealer to inform you on basic motorcycle maintenance. Certain maintenance can only be carried out by certified staff.



- Many accidents involve inexperienced operators. In fact, many operators who have been involved in accidents do not even have a current motorcycle license.
 - Make sure that you are qualified and that you only lend your motorcycle to other qualified operators.
 - Know your skills and limits. Staying within your limits may help you to avoid an accident.
 - We recommend that you practice riding your motorcycle where there is no traffic until you have become thoroughly familiar with the motorcycle and all of its controls.
- Many accidents have been caused by error of the motorcycle operator. A typical error made by the operator is veering wide on a turn due to excessive speed or undercornering (insufficient lean angle for the speed).
 - Always obey the speed limit and never travel faster than warranted by road and traffic conditions.
 - Always signal before turning or changing lanes. Make sure that other motorists can see you.
- The posture of the operator and passenger is important for proper control.
 - The operator should keep both hands on the handlebar and both feet on the operator footrests during operation to maintain control of the motorcycle.
 - The passenger should always hold onto the operator, the seat strap or grab bar, if equipped, with both hands and keep both feet on the passenger footrests. Never carry a passenger unless he or she can firmly place both feet on the passenger footrests.
- Never ride under the influence of alcohol or other drugs.
- This motorcycle is designed for on-road use only. It is not suitable for off-road use.

Protective Apparel

The majority of fatalities from motorcycle accidents are the result of head injuries. The use of a safety helmet is the single most critical factor in the prevention or reduction of head injuries.

- Always wear an approved helmet.
- Wear a face shield or goggles. Wind in your unprotected eyes could contribute to an impairment of vision that could delay seeing a hazard.
- The use of a jacket, heavy boots, trousers, gloves, etc., is effective in preventing or reducing abrasions or lacerations.
- Never wear loose-fitting clothes, otherwise they could catch on the control levers, footrests, or wheels and cause injury or an accident.
- Always wear protective clothing that covers your legs, ankles, and feet. The engine or exhaust system become very hot during or after operation and can cause burns.
- A passenger should also observe the above precautions.

SAFETY INFORMATION

2

Avoid Carbon Monoxide Poisoning

All engine exhaust contains carbon monoxide, a deadly gas. Breathing carbon monoxide can cause headaches, dizziness, drowsiness, nausea, confusion, and eventually death.

Carbon Monoxide is a colorless, odorless, tasteless gas which may be present even if you do not see or smell any engine exhaust. Deadly levels of carbon monoxide can collect rapidly and you can quickly be overcome and unable to save yourself. Also, deadly levels of carbon monoxide can linger for hours or days in enclosed or poorly ventilated areas. If you experience any symptoms of carbon monoxide poisoning, leave the area immediately, get fresh air, and **SEEK MEDICAL TREATMENT.**

- Do not run engine indoors. Even if you try to ventilate engine exhaust with fans or open windows and doors, carbon monoxide can rapidly reach dangerous levels.
- Do not run engine in poorly ventilated or partially enclosed areas such as barns, garages, or carports.

- Do not run engine outdoors where engine exhaust can be drawn into a building through openings such as windows and doors.

Loading

Adding accessories or cargo to your motorcycle can adversely affect stability and handling if the weight distribution of the motorcycle is changed. To avoid the possibility of an accident, use extreme caution when adding cargo or accessories to your motorcycle. Use extra care when riding a motorcycle that has added cargo or accessories. Here, along with the information about accessories below, are some general guidelines to follow if loading cargo to your motorcycle:

The total weight of the operator, passenger, accessories and cargo must not exceed the maximum load limit.

Operation of an overloaded vehicle could cause an accident.

<p>Maximum load: 151 kg (333 lb)</p>

When loading within this weight limit, keep the following in mind:

- Cargo and accessory weight should be kept as low and close to the motorcycle as possible. Securely pack your heaviest items as close to the center of the vehicle as possible and make sure to distribute the weight as evenly as possible on both sides of the motorcycle to minimize imbalance or instability.
- Shifting weights can create a sudden imbalance. Make sure that accessories and cargo are securely attached to the motorcycle before riding. Check accessory mounts and cargo restraints frequently.
- Properly adjust the suspension for your load (suspension-adjustable models only), and check the condition and pressure of your tires.
- Never attach any large or heavy items to the handlebar, front fork, or front fender. These items, including such cargo as sleeping bags, duffel bags, or

tents, can create unstable handling or a slow steering response.

- **This vehicle is not designed to pull a trailer or to be attached to a sidecar.**

Genuine Yamaha Accessories

Choosing accessories for your vehicle is an important decision. Genuine Yamaha accessories, which are available only from a Yamaha dealer, have been designed, tested, and approved by Yamaha for use on your vehicle.

Many companies with no connection to Yamaha manufacture parts and accessories or offer other modifications for Yamaha vehicles. Yamaha is not in a position to test the products that these aftermarket companies produce. Therefore, Yamaha can neither endorse nor recommend the use of accessories not sold by Yamaha or modifications not specifically recommended by Yamaha, even if sold and installed by a Yamaha dealer.

Aftermarket Parts, Accessories, and Modifications

While you may find aftermarket products similar in design and quality to genuine Yamaha accessories, recognize that some aftermarket accessories or modifications are not suitable because of potential safety hazards to you or others. Installing aftermarket products or having other modifications performed to your vehicle that change any of the vehicle's design or operation characteristics can put you and others at greater risk of serious injury or death. You are responsible for injuries related to changes in the vehicle.

Keep the following guidelines in mind, as well as those provided under "Loading" when mounting accessories.

- Never install accessories or carry cargo that would impair the performance of your motorcycle. Carefully inspect the accessory before using it to make sure that it does not in any way reduce ground clearance or cornering clearance, limit suspension travel,

steering travel or control operation, or obscure lights or reflectors.

- Accessories fitted to the handlebar or the front fork area can create instability due to improper weight distribution or aerodynamic changes. If accessories are added to the handlebar or front fork area, they must be as lightweight as possible and should be kept to a minimum.
- Bulky or large accessories may seriously affect the stability of the motorcycle due to aerodynamic effects. Wind may attempt to lift the motorcycle, or the motorcycle may become unstable in cross winds. These accessories may also cause instability when passing or being passed by large vehicles.
- Certain accessories can displace the operator from his or her normal riding position. This improper position limits the freedom of movement of the

SAFETY INFORMATION

2

operator and may limit control ability, therefore, such accessories are not recommended.

- Use caution when adding electrical accessories. If electrical accessories exceed the capacity of the motorcycle's electrical system, an electric failure could result, which could cause a dangerous loss of lights or engine power.

Aftermarket Tires and Rims

The tires and rims that came with your motorcycle were designed to match the performance capabilities and to provide the best combination of handling, braking, and comfort. Other tires, rims, sizes, and combinations may not be appropriate. Refer to page 7-17 for tire specifications and more information on replacing your tires.

Transporting the Motorcycle

Be sure to observe following instructions before transporting the motorcycle in another vehicle.

- Remove all loose items from the motorcycle.

- Check that the fuel cock (if equipped) is in the "OFF" position and that there are no fuel leaks.
- Point the front wheel straight ahead on the trailer or in the truck bed, and choke it in a rail to prevent movement.
- Shift the transmission in gear (for models with a manual transmission).
- Secure the motorcycle with tie-downs or suitable straps that are attached to solid parts of the motorcycle, such as the frame or upper front fork triple clamp (and not, for example, to rubber-mounted handlebars or turn signals, or parts that could break). Choose the location for the straps carefully so the straps will not rub against painted surfaces during transport.
- The suspension should be compressed somewhat by the tie-downs, if possible, so that the motorcycle will not bounce excessively during transport.

Further safe-riding points

EAU57610

- Be sure to signal clearly when making turns.
- Braking can be extremely difficult on a wet road. Avoid hard braking, because the motorcycle could slide. Apply the brakes slowly when stopping on a wet surface.
- Slow down as you approach a corner or turn. Once you have completed a turn, accelerate slowly.
- Be careful when passing parked cars. A driver might not see you and open a door in your path.
- Railroad crossings, streetcar rails, iron plates on road construction sites, and manhole covers become extremely slippery when wet. Slow down and cross them with caution. Keep the motorcycle upright, otherwise it could slide out from under you.
- The brake pads or linings could get wet when you wash the motorcycle. After washing the motorcycle, check the brakes before riding.

- Always wear a helmet, gloves, trousers (tapered around the cuff and ankle so they do not flap), and a brightly colored jacket.
- Do not carry too much luggage on the motorcycle. An overloaded motorcycle is unstable. Use a strong cord to secure any luggage to the carrier (if equipped). A loose load will affect the stability of the motorcycle and could divert your attention from the road. (See page 2-3.)

Helmets

Operating this vehicle without an approved motorcycle helmet increases your chances of a severe head injury or death in the event of an accident. The majority of fatalities from motorcycle or scooter accidents are the result of head injuries. The use of a safety helmet is the single most critical factor in the prevention or reduction of head injuries.

Always select an approved motorcycle helmet

Pay attention to the following when choosing a motorcycle helmet.

- The helmet must meet the safety standard “TIS”.
- The helmet size must match the size of the rider’s head.
- Never subject a helmet to heavy shocks.

Wearing the helmet correctly

Always connect the chin strap. In the case of an accident, the helmet has a much less chance of coming off if the chin strap is connected.

EAUU0033

Correct usage



ZAUU0003

Wrong usage



ZAUU0007

Types of helmets and their usage

- Half-type: use only for riding at low speeds

SAFETY INFORMATION

2

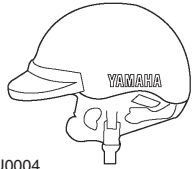

ZAUU0004



ZAUU0006

- Full-type: use only for riding at low to mid-range speeds

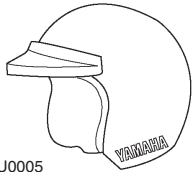

ZAUU0005

- Full-face-type: use for riding at mid-range to high speeds

Left view

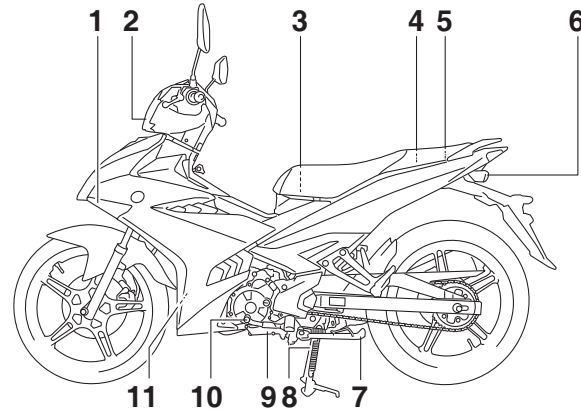

1. Front turn signal light (page 7-33)
2. Headlight (page 7-31)
3. Air filter element (page 7-14)
4. Battery (page 7-29)
5. Owner's tool kit (page 7-1)
6. Rear turn signal light (page 7-33/7-32)
7. Sidestand (page 4-14)
8. Centerstand (page 7-27)

9. Engine oil drain bolt (page 7-10)
10. Shift pedal (page 4-8)
11. Coolant reservoir (page 7-12)

DESCRIPTION

EAU10421

Right view

3

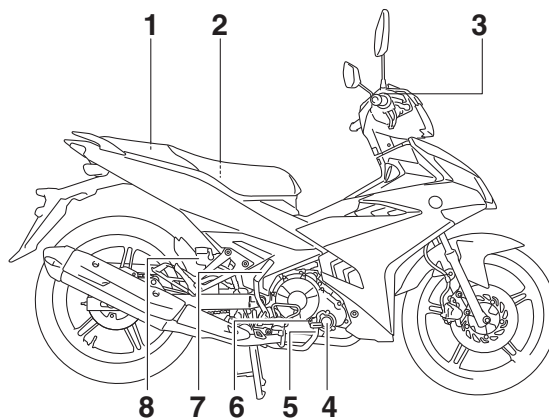

1. Fuses (page 7-30)
2. Fuel tank cap (page 4-9)
3. Front brake fluid reservoir (page 7-22)
4. Engine oil filter element (page 7-10)
5. Brake pedal (page 4-9)
6. Dipstick (page 7-10)
7. Kickstarter (page 4-12)
8. Rear brake fluid reservoir (page 7-22)

Controls and instruments

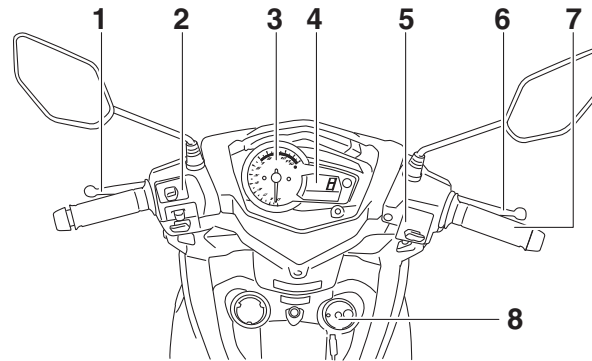

1. Clutch lever (page 4-8)
2. Left handlebar switches (page 4-7)
3. Tachometer
4. Multi-function display (page 4-4)
5. Right handlebar switch (page 4-7)
6. Brake lever (page 4-8)
7. Throttle grip (page 7-16)
8. Main switch/steering lock (page 4-1)

INSTRUMENT AND CONTROL FUNCTIONS

Main switch/steering lock

EAUJ0351

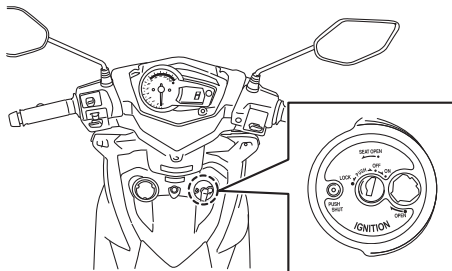

4

The main switch/steering lock controls the ignition and lighting systems, and is used to lock the steering, and is used to open the seat also. The various main switch positions are described below.

TIP

The main switch is equipped with a keyhole cover. (See page 4-2 for keyhole cover opening and closing procedures.)

ON

EAU65810

All electrical circuits are supplied with power, and the engine can be started. The key cannot be removed.

TIP

- The meter lighting, taillight, license plate light and auxiliary light come on automatically when the key is turned to “ON”.
- The fuel pump can be heard when the key is turned to “ON”.

OFF

EAUJ1131

All electrical systems are off. The key can be removed.

LOCK

EAUJ1042

The steering is locked, and all electrical systems are off. The key can be removed.

To lock the steering

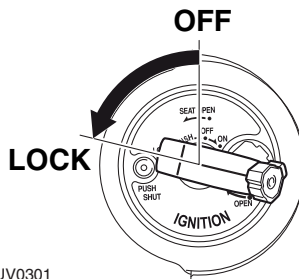

ZAUJ0301

4-1

1. Turn the handlebars all the way to the left.
2. Push the key in from the “OFF” position, and then turn it to “LOCK” while still pushing it.
3. Remove the key.

To unlock the steering

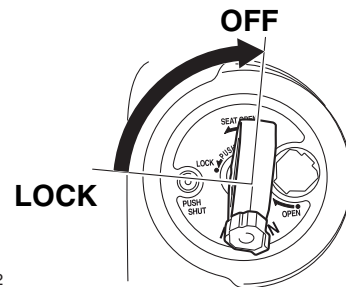

ZAUJ0302

Push the key in, and then turn it to “OFF” while still pushing it.

EWAJ0042

⚠ WARNING

- **Never turn the key to “OFF” or “LOCK” while the vehicle is moving; otherwise, the electrical systems will be switched off, which may result in loss of control or an accident.**

INSTRUMENT AND CONTROL FUNCTIONS

- If the vehicle turns over, and after placing it upright, ensure that there is no fuel leakage. If fuel is leaking, have a Yamaha dealer check the vehicle.

Keyhole cover

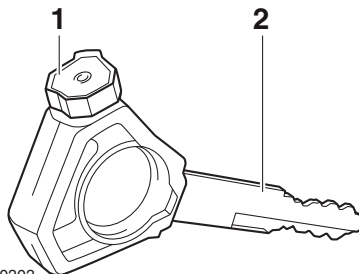

ZAUU0303

1. Key head
2. Ignition key

To open the keyhole cover

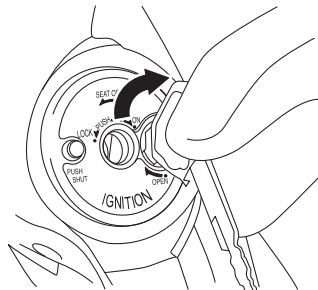

Insert the key head into the keyhole cover receptacle as shown, and then turn the key to the right to open the cover.

EAUU0822

To close the keyhole cover

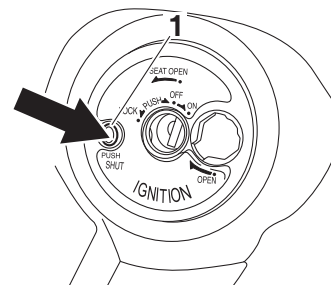

1. Push.

Press the “PUSH SHUT” button to close the keyhole cover.

INSTRUMENT AND CONTROL FUNCTIONS

Indicator lights and warning lights

EAU49398

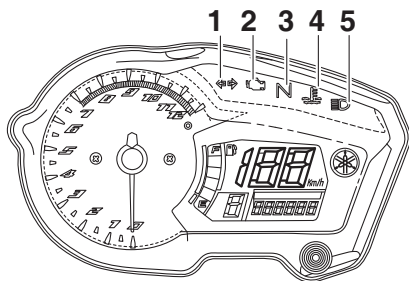

1. Turn signal indicator light “↔”
2. Engine trouble warning light “🔧”
3. Neutral indicator light “N”
4. Coolant temperature warning light “🌡️”
5. High beam indicator light “≡〇”

Turn signal indicator light “↔”

EAU11022

This indicator light flashes when a turn signal light is flashing.

Neutral indicator light “N”

EAU11061

This indicator light comes on when the transmission is in the neutral position.

High beam indicator light “≡〇”

EAU11081

This indicator light comes on when the high beam of the headlight is switched on.

Coolant temperature warning light “🌡️”

EAU11447

This warning light comes on if the engine overheats. If this occurs, stop the engine immediately and allow the engine to cool.

The electrical circuit of the warning light can be checked by turning the key to “ON”. The warning light should come on for a few seconds, and then go off.

If the warning light does not come on initially when the key is turned to “ON”, or if the warning light remains on, have a Yamaha dealer check the electrical circuit.

NOTICE

ECA10022

Do not continue to operate the engine if it is overheating.

TIP

- For radiator-fan-equipped vehicles, the radiator fan(s) automatically switch on or off according to the coolant temperature in the radiator.
- If the engine overheats, see page 7-39 for further instructions.

Engine trouble warning light “🔧”

EAU11506

This warning light comes on or flashes if a problem is detected in the electrical circuit monitoring the engine. If this occurs, have a Yamaha dealer check the self-diagnosis system.

The electrical circuit of the warning light can be checked by turning the key to “ON”. The warning light should come on for a few seconds, and then go off.

If the warning light does not come on initially when the key is turned to “ON”, or if the warning light remains on, have a Yamaha dealer check the electrical circuit.

INSTRUMENT AND CONTROL FUNCTIONS

fuel level is very low, and the tank should be refueled as soon as possible.

TIP

Do not use up all of the fuel in the fuel tank.

ECAV0041

NOTICE

When the fuel indicator has dropped to only one block, refuel as soon as possible, as the movement of fuel when going up or downhill or when turning may lead to the engine not getting any fuel, resulting in engine stop.

Transmission gear display

The display shows the selected gear. The neutral position is indicated by “-” and by the neutral indicator light.

Multi-function display

The multi-function display contains:

- “ODO” – odometer
- “TRIP1” – tripmeter 1
- “TRIP2” – tripmeter 2
- “F/ECO” – instantaneous fuel economy

- “AVE F/ECO” – average fuel economy
- “AVE SPEED” – average speed
- a welcome screen
- a self-diagnosis device

Push the “SELECT” button to switch the display between “ODO”, “TRIP1”, “TRIP2”, “F/ECO”, “AVE F/ECO”, and “AVE SPEED” in the following order:

ODO → TRIP1 → TRIP2 → F/ECO → AVE F/ECO → AVE SPEED → ODO

“ODO” – odometer

The odometer shows the total distance traveled by the vehicle. It cannot be reset.

“TRIP1” & “TRIP2” – tripmeters

The tripmeters show the total distance traveled since they were last reset.

To reset a tripmeter, push the “SELECT” button for one second.

“F/ECO” – instantaneous fuel economy

Shows the current fuel economy (fuel consumption) when the vehicle is traveling 10 km/h or more.

There are two display modes: “km/L” and “L/100km”. To switch the instantaneous fuel economy display between “km/L” and “L/100km”, push the “SELECT” button for one second.

- “km/L”: The distance that can be traveled on 1.0 L of fuel under current riding conditions.
- “L/100km”: The amount of fuel necessary to travel 100 km under current riding conditions.

TIP

- When traveling at speeds under 10 km/h, “_ _ _” will be displayed.
- The instantaneous fuel economy function should be used for general reference only. Be aware of the amount of fuel remaining in the tank. Check the fuel gauge from time to time.

“AVE F/ECO” – average fuel economy

Shows the average fuel economy (fuel consumption) since it was last reset.

There are two display modes: “AVE_ _ _ km/L” and “AVE_ _ _ L/100km”. To switch the average fuel economy dis-

INSTRUMENT AND CONTROL FUNCTIONS

play between “AVE_ _ _ km/L” and “AVE_ _ _ L/100km”, push the “SELECT” button for one second.

- “AVE_ _ _ km/L”: The average distance that can be traveled on 1.0 L of fuel.
- “AVE_ _ _ L/100km”: The average amount of fuel necessary to travel 100 km under current riding conditions.

To reset the average fuel economy display, push the “SELECT” button for one second.

TIP

- After resetting the average fuel economy display, “_ _ _” will be displayed until the vehicle has traveled 1 km.

ECA15474

NOTICE

If there is a malfunction, “- _ -” will be continuously displayed. Have a Yamaha dealer check the vehicle.

“AVE SPEED” – average speed

Shows the vehicle's average travelling speed since it was last reset.

To reset the average speed display, push the “SELECT” button until the average speed flashes, and then push the button again.

Welcome screen

The welcome screen greets the rider when the key is turned to “ON” with the messages “Hi Buddy” and “Ready to GO”. The user name “Buddy” is set as the factory default, but it can be set to your name.

To set the user name

1. Turn the key to “OFF”.
2. Push and hold the “SELECT” button.
3. Turn the key to “ON”, and then release “SELECT” button after four seconds.
4. When the first character starts flashing, push the “SELECT” button to change the character in the following order.

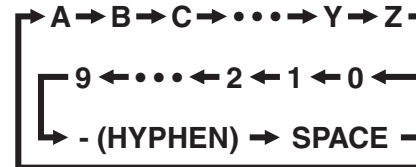

5. Push the “SELECT” button for one second to confirm the selected character. The second character will start flashing. Repeat this process for all six characters. After the sixth character is set, all characters will flash twice and the setting mode will automatically end.

Self-diagnosis device

This model is equipped with a self-diagnosis device for various electrical circuits.

If a problem is detected in any of those circuits, the engine trouble warning light will come on and the display will indicate an error code.

INSTRUMENT AND CONTROL FUNCTIONS

If the display indicates any error codes, note the code number, and then have a Yamaha dealer check the vehicle.

ECA11171

NOTICE

To prevent engine damage, be sure to consult a Yamaha dealer as soon as possible if this occurs.



4

Handlebar switches

EAU1234H

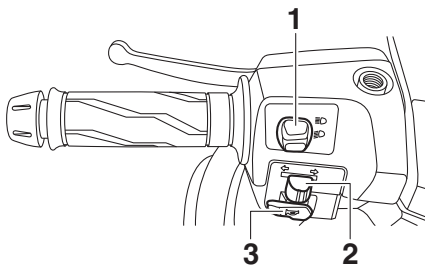
Left



1. Dimmer switch “/”
2. Turn signal switch “/”
3. Horn switch “”

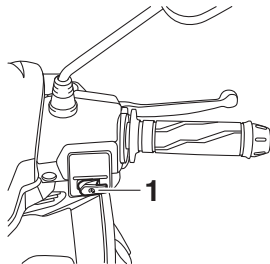

Right



1. Start switch “”



Dimmer switch “/”

EAU12401

Set this switch to “” for the high beam and to “” for the low beam.

Turn signal switch “/”

EAU12461

To signal a right-hand turn, push this switch to “”. To signal a left-hand turn, push this switch to “”. When released, the switch returns to the center position. To cancel the turn signal lights, push the switch in after it has returned to the center position.

Horn switch “”

EAU12501

Press this switch to sound the horn.

Start switch “”

EAU12713

Push this switch to crank the engine with the starter. See page 6-2 for starting instructions prior to starting the engine.

INSTRUMENT AND CONTROL FUNCTIONS

Clutch lever

EAU31641

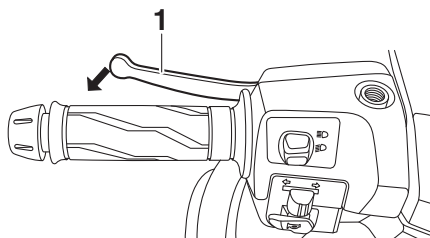

1. Clutch lever

The clutch lever is located at the left handlebar grip. To disengage the clutch, pull the lever toward the handlebar grip. To engage the clutch, release the lever. The lever should be pulled rapidly and released slowly for smooth clutch operation.

The clutch lever is equipped with a clutch switch, which is part of the starting circuit cut-off system. (See page 4-14.)

Shift pedal

EAU12872

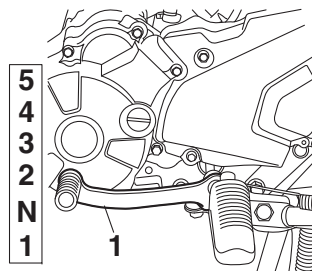

1. Shift pedal

The shift pedal is located on the left side of the motorcycle and is used in combination with the clutch lever when shifting the gears of the 5-speed constant-mesh transmission equipped on this motorcycle.

Brake lever

EAU12892

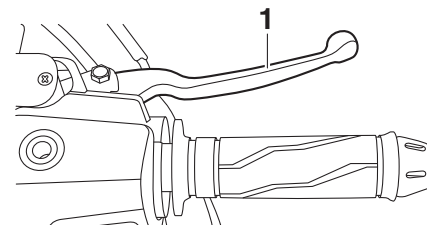

1. Brake lever

The brake lever is located on the right side of the handlebar. To apply the front brake, pull the lever toward the throttle grip.

INSTRUMENT AND CONTROL FUNCTIONS

EAU12944

Brake pedal

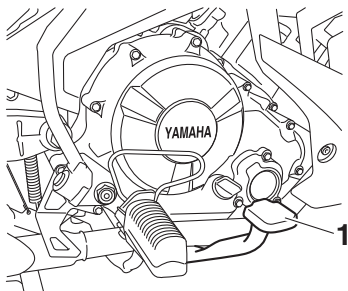

1. Brake pedal

The brake pedal is located on the right side of the motorcycle. To apply the rear brake, press down on the brake pedal.

EAU37473

Fuel tank cap

To remove the fuel tank cap

1. Open the seat. (See page 4-12.)
2. Turn the fuel tank cap counter-clockwise and pull it off.

To install the fuel tank cap

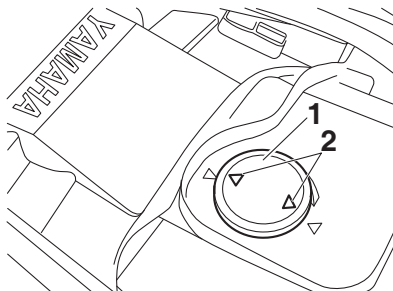

1. Fuel tank cap
2. “△” mark

1. Insert the fuel tank cap into the tank opening and turn it clockwise until the “△” marks on the cap and tank are aligned.
2. Close the seat.

EWA11092



Make sure that the fuel tank cap is properly closed after filling fuel. Leaking fuel is a fire hazard.

INSTRUMENT AND CONTROL FUNCTIONS

Fuel

Make sure there is sufficient gasoline in the tank.

EAU13233

EWA10882

WARNING

Gasoline and gasoline vapors are extremely flammable. To avoid fires and explosions and to reduce the risk of injury when refueling, follow these instructions.

1. Before refueling, turn off the engine and be sure that no one is sitting on the vehicle. Never refuel while smoking, or while in the vicinity of sparks, open flames, or other sources of ignition such as the pilot lights of water heaters and clothes dryers.
2. Do not overfill the fuel tank.

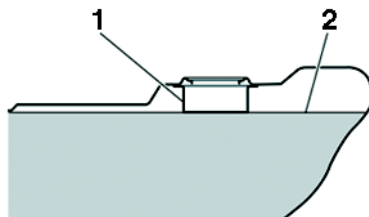

1. Fuel tank filler tube
2. Maximum fuel level
3. Wipe up any spilled fuel immediately. **NOTICE: Immediately wipe off spilled fuel with a clean, dry, soft cloth, since fuel may deteriorate painted surfaces or plastic parts.** [ECA110072]
4. Be sure to securely close the fuel tank cap.

WARNING

Gasoline is poisonous and can cause injury or death. Handle gasoline with care. Never siphon gasoline by mouth. If you should swallow some gasoline or inhale a lot of gasoline vapor, or get some gasoline in your eyes, see your doctor immedi-

ately. If gasoline spills on your skin, wash with soap and water. If gasoline spills on your clothing, change your clothes.

EAUU0045

Recommended fuel:

Regular unleaded gasoline (Gasohol (E10) acceptable)

Fuel tank capacity:

4.2 L (1.11 US gal, 0.92 Imp.gal)

4

ECA11401

NOTICE

Use only unleaded gasoline. The use of leaded gasoline will cause severe damage to internal engine parts, such as the valves and piston rings, as well as to the exhaust system.

Gasohol

There are two types of gasohol: gasohol containing ethanol and that containing methanol. Gasohol containing ethanol can be used if the ethanol content does not exceed 10% (E10). Gasohol containing methanol is not

INSTRUMENT AND CONTROL FUNCTIONS

recommended by Yamaha because it can cause damage to the fuel system or vehicle performance problems.

EAU13434

ECA10702

Catalytic converter

This model is equipped with a catalytic converter in the exhaust system.

EWA10863

WARNING

The exhaust system is hot after operation. To prevent a fire hazard or burns:

- Do not park the vehicle near possible fire hazards such as grass or other materials that easily burn.
 - Park the vehicle in a place where pedestrians or children are not likely to touch the hot exhaust system.
 - Make sure that the exhaust system has cooled down before doing any maintenance work.
 - Do not allow the engine to idle more than a few minutes. Long idling can cause a build-up of heat.
-

NOTICE

Use only unleaded gasoline. The use of leaded gasoline will cause unreparable damage to the catalytic converter.

INSTRUMENT AND CONTROL FUNCTIONS

Kickstarter

EAUE0861

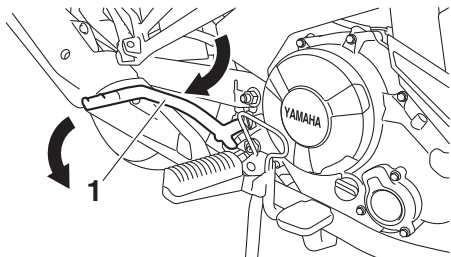

1. Kickstarter

To start the engine, fold the right footrest inward, and then fold out the kickstarter lever. Move it down lightly with your foot until the gears engage, and then push it down smoothly but forcefully. Fold the footrest outward to its original position.

This model is equipped with a primary kickstarter, allowing the engine to be started in any gear if the clutch is disengaged. However, shifting the transmission into the neutral position before starting is recommended.

Seat

EAUU0371

To open the seat

1. Place the motorcycle on the centerstand.
2. Insert the key into the main switch, and then turn it counterclockwise to "OPEN".

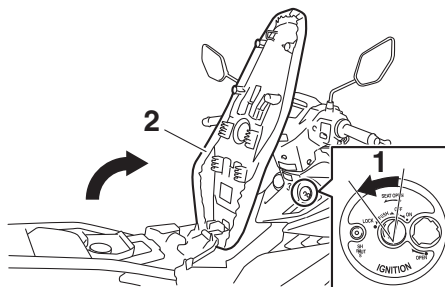

1. Seat lock
2. Seat

TIP

Do not push inward when turning the key.

3. Fold the seat up.

To close the seat

1. Fold the seat down, and then push it down to lock it in place.
2. Remove the key from the main switch if the motorcycle will be left unattended.

TIP

Make sure that the seat is properly secured before riding.

INSTRUMENT AND CONTROL FUNCTIONS

Helmet holders

EAU37482

To release a helmet from a helmet holder

Open the seat, remove the helmet from the helmet holder, and then close the seat.

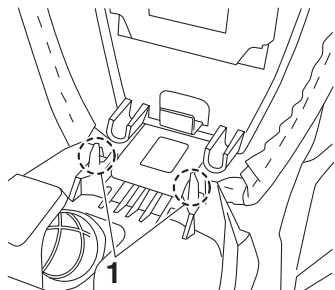

1. Helmet holder

The helmet holders are located under the seat.

To secure a helmet to a helmet holder

1. Open the seat. (See page 4-12.)
2. Attach a helmet to a helmet holder, and then securely close the seat. **WARNING! Never ride with a helmet attached to the helmet holder, since the helmet may hit objects, causing loss of control and possibly an accident.** [EWA10162]

Storage compartment

EAU37892

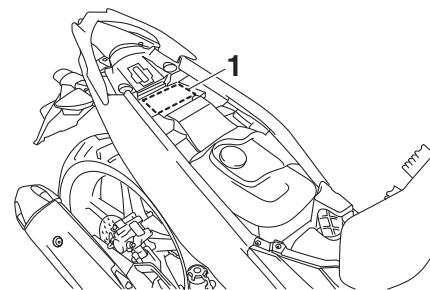

1. Storage compartment

The storage compartment is located under the seat. (See page 4-12.)

When storing the Owner's Manual or other documents in the storage compartment, be sure to wrap them in a plastic bag so that they will not get wet. When washing the vehicle, be careful not to let any water enter the storage compartment.

Sidestand

EAU37491

The sidestand is located on the left side of the frame. Raise the sidestand or lower it with your foot while holding the vehicle upright.

EWA14191



The vehicle must not be ridden with the sidestand down, or if the sidestand cannot be properly moved up (or does not stay up), otherwise the sidestand could contact the ground and distract the operator, resulting in a possible loss of control.

Starting circuit cut-off system

EAUU0633

The starting circuit cut-off system (comprising the clutch switch and the neutral switch) prevents starting when the transmission is in gear and the clutch lever is not pulled.

Periodically check the operation of the starting circuit cut-off system according to the following procedure.

TIP

This check is most reliable if performed with a warmed-up engine.

INSTRUMENT AND CONTROL FUNCTIONS

4

With the engine turned off:
1. Turn the key to the on position.
2. Shift the transmission into the neutral position.
3. Push the start switch.
Does the engine start?

YES

NO

4. Turn the engine off.
5. Shift the transmission into gear.
6. Keep the clutch lever pulled.
7. Push the start switch.
Does the engine start?

YES

NO

The system is OK. **The motorcycle can be ridden.**



If a malfunction is noted, have a Yamaha dealer check the system before riding.

The neutral switch may not be working correctly.
The motorcycle should not be ridden until checked by a Yamaha dealer.

The clutch switch may not be working correctly.
The motorcycle should not be ridden until checked by a Yamaha dealer.

FOR YOUR SAFETY – PRE-OPERATION CHECKS

EAU15599

Inspect your vehicle each time you use it to make sure the vehicle is in safe operating condition. Always follow the inspection and maintenance procedures and schedules described in the Owner's Manual.

EWA11152

WARNING

Failure to inspect or maintain the vehicle properly increases the possibility of an accident or equipment damage. Do not operate the vehicle if you find any problem. If a problem cannot be corrected by the procedures provided in this manual, have the vehicle inspected by a Yamaha dealer.

Before using this vehicle, check the following points:

ITEM	CHECKS	PAGE
Fuel	<ul style="list-style-type: none">• Refuel if necessary.• Check fuel line for leakage.	4-10
Engine oil	<ul style="list-style-type: none">• Check oil level in engine.• If necessary, add recommended oil to specified level.• Check vehicle for oil leakage.	7-10
Coolant	<ul style="list-style-type: none">• Check coolant level in reservoir.• If necessary, add recommended coolant to specified level.• Check cooling system for leakage.	7-12
Front brake	<ul style="list-style-type: none">• Check operation.• If soft or spongy, have Yamaha dealer bleed hydraulic system.• Check brake pads for wear.• Replace if necessary.• Check fluid level in reservoir.• If necessary, add specified brake fluid to specified level.• Check hydraulic system for leakage.	7-21, 7-22

FOR YOUR SAFETY – PRE-OPERATION CHECKS

ITEM	CHECKS	PAGE
Rear brake	<ul style="list-style-type: none"> • Check operation. • If soft or spongy, have Yamaha dealer bleed hydraulic system. • Check brake pads for wear. • Replace if necessary. • Check fluid level in reservoir. • If necessary, add specified brake fluid to specified level. • Check hydraulic system for leakage. 	7-21, 7-22
Clutch	<ul style="list-style-type: none"> • Check operation. • Lubricate cable if necessary. • Check lever free play. • Adjust if necessary. 	7-19
Throttle grip	<ul style="list-style-type: none"> • Make sure that operation is smooth. • Check throttle grip free play. • If necessary, have Yamaha dealer adjust throttle grip free play and lubricate cable and grip housing. 	7-16, 7-25
Control cables	<ul style="list-style-type: none"> • Make sure that operation is smooth. • Lubricate if necessary. 	7-25
Drive chain	<ul style="list-style-type: none"> • Check chain slack. • Adjust if necessary. • Check chain condition. • Lubricate if necessary. 	7-23, 7-25
Wheels and tires	<ul style="list-style-type: none"> • Check for damage. • Check tire condition and tread depth. • Check air pressure. • Correct if necessary. 	7-17, 7-18
Shift pedal	<ul style="list-style-type: none"> • Make sure that operation is smooth. • Correct if necessary. 	7-20
Brake pedal	<ul style="list-style-type: none"> • Make sure that operation is smooth. • Lubricate pedal pivoting point if necessary. 	7-26
Brake and clutch levers	<ul style="list-style-type: none"> • Make sure that operation is smooth. • Lubricate lever pivoting points if necessary. 	7-26

FOR YOUR SAFETY – PRE-OPERATION CHECKS

ITEM	CHECKS	PAGE
Centerstand, sidestand	<ul style="list-style-type: none">• Make sure that operation is smooth.• Lubricate pivots if necessary.	7-27
Chassis fasteners	<ul style="list-style-type: none">• Make sure that all nuts, bolts and screws are properly tightened.• Tighten if necessary.	—
Instruments, lights, signals and switches	<ul style="list-style-type: none">• Check operation.• Correct if necessary.	—

OPERATION AND IMPORTANT RIDING POINTS

EAU15952

Read the Owner's Manual carefully to become familiar with all controls. If there is a control or function you do not understand, ask your Yamaha dealer.

EWA10272

WARNING

Failure to familiarize yourself with the controls can lead to loss of control, which could cause an accident or injury.

EAUU1062

TIP

- This model is equipped with a lean angle sensor to stop the engine in case the vehicle tilts more than 65°. To restart the engine, turn the key to "OFF" and then to "ON". Failing to do so will prevent the engine from starting.
 - The engine cannot be started if the battery voltage is less than 11.50 volts or the battery is not installed.
-

EAUN0073

ECAN0072

NOTICE

Do not ride through deep water, otherwise the engine may be damaged. Avoid puddles because they may be deeper than expected.

OPERATION AND IMPORTANT RIDING POINTS

Starting the engine

EAU65820

In order for the starting circuit cut-off system to enable starting, one of the following conditions must be met:

- The transmission is in the neutral position.
- The transmission is in gear with the clutch lever pulled.

See page 4-14 for more information.

1. Turn the key to "ON". The engine trouble warning light should come on for a few seconds, then go off.

NOTICE: If the warning light does not go off, have a Yamaha dealer check its electrical circuit.

[ECAT1121]

2. Shift the transmission into the neutral position. The neutral indicator light should come on. If not, ask a Yamaha dealer to check the electrical circuit.
3. Start the engine by pushing the start switch. If the engine fails to start, try again with the throttle grip open 1/4 turn (10 mm). Each starting attempt should be as short as possible to preserve the

battery. Do not crank the engine more than 10 seconds on any one attempt.

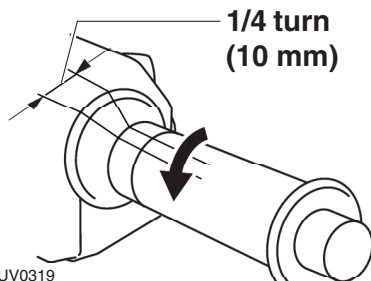

NOTICE

For maximum engine life, never accelerate hard when the engine is cold!

Shifting

EAU16673

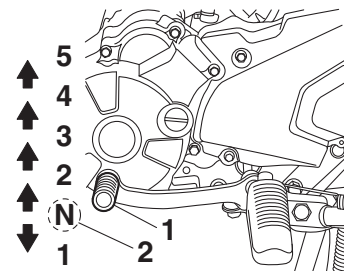

1. Shift pedal
2. Neutral position

Shifting gears lets you control the amount of engine power available for starting off, accelerating, climbing hills, etc.

The gear positions are shown in the illustration.

TIP

To shift the transmission into the neutral position, press the shift pedal down repeatedly until it reaches the end of its travel, and then slightly raise it.

OPERATION AND IMPORTANT RIDING POINTS

6

NOTICE

ECA10261

- Even with the transmission in the neutral position, do not coast for long periods of time with the engine off, and do not tow the motorcycle for long distances. The transmission is properly lubricated only when the engine is running. Inadequate lubrication may damage the transmission.
 - Always use the clutch while changing gears to avoid damaging the engine, transmission, and drive train, which are not designed to withstand the shock of forced shifting.
-

Tips for reducing fuel consumption

EAU16811

Fuel consumption depends largely on your riding style. Consider the following tips to reduce fuel consumption:

- Shift up swiftly, and avoid high engine speeds during acceleration.
- Do not rev the engine while shifting down, and avoid high engine speeds with no load on the engine.
- Turn the engine off instead of letting it idle for an extended length of time (e.g., in traffic jams, at traffic lights or at railroad crossings).

EAU16842

Engine break-in

There is never a more important period in the life of your engine than the period between 0 and 1600 km (1000 mi). For this reason, you should read the following material carefully.

Since the engine is brand new, do not put an excessive load on it for the first 1600 km (1000 mi). The various parts in the engine wear and polish themselves to the correct operating clearances. During this period, prolonged full-throttle operation or any condition that might result in engine overheating must be avoided.

EAU17103

0–1000 km (0–600 mi)

Avoid prolonged operation above 5000 r/min. **NOTICE: After 1000 km (600 mi) of operation, the engine oil must be changed, and the oil filter element replaced.** [ECA11152]

1000–1600 km (600–1000 mi)

Avoid prolonged operation above 7500 r/min.

OPERATION AND IMPORTANT RIDING POINTS

1600 km (1000 mi) and beyond

The vehicle can now be operated normally.

ECA10311

NOTICE

- Keep the engine speed out of the tachometer red zone.
 - If any engine trouble should occur during the engine break-in period, immediately have a Yamaha dealer check the vehicle.
-

EAU17214

Parking

When parking, stop the engine, and then remove the key from the main switch.

EWA10312

⚠ WARNING

- Since the engine and exhaust system can become very hot, park in a place where pedestrians or children are not likely to touch them and be burned.
 - Do not park on a slope or on soft ground, otherwise the vehicle may overturn, increasing the risk of a fuel leak and fire.
 - Do not park near grass or other flammable materials which might catch fire.
-

OPERATION AND IMPORTANT RIDING POINTS

EAUU1241

General note

Much can be gained from the correct use and maintenance of a motorcycle.

1. THE CUSTOMERS CAN USE THE FULLEST POTENTIAL OF YAMAHA MOTORCYCLES

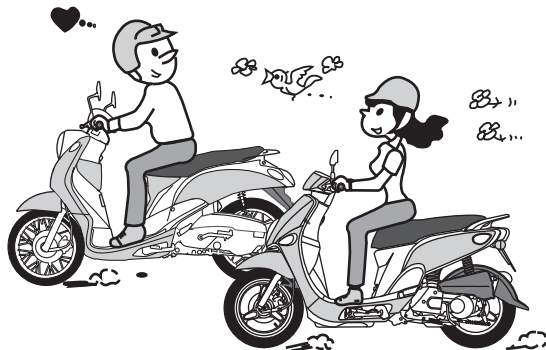

ZAUU0736

2. A MOTORCYCLE CAN KEEP ITS PERFORMANCE CAPABILITY FOR A LONGER TIME

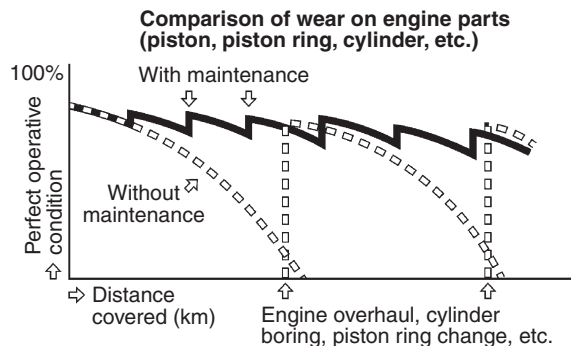

OPERATION AND IMPORTANT RIDING POINTS

3. FUEL COST AND REPAIR EXPENSES CAN BE KEPT TO A MINIMUM

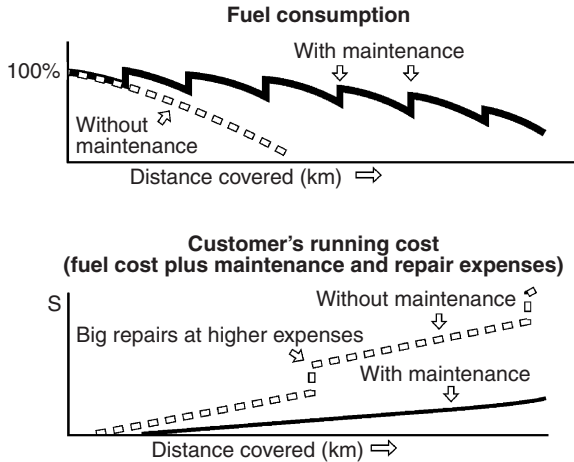

ZAUU0737

4. A MOTORCYCLE CAN DEMAND A HIGH PRICE WHEN IT IS TRADED IN AS A USED PRODUCT

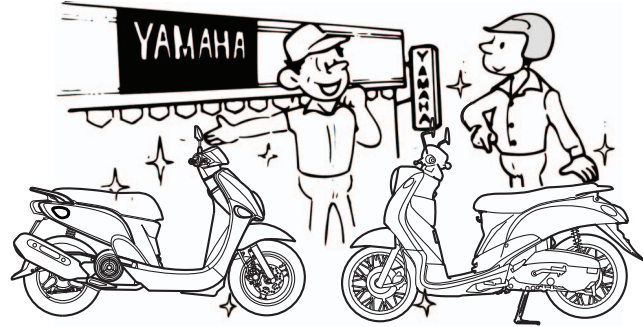

PERIODIC MAINTENANCE AND ADJUSTMENT

EAU17245

Periodic inspection, adjustment, and lubrication will keep your vehicle in the safest and most efficient condition possible. Safety is an obligation of the vehicle owner/operator. The most important points of vehicle inspection, adjustment, and lubrication are explained on the following pages.

The intervals given in the periodic maintenance charts should be simply considered as a general guide under normal riding conditions. However, depending on the weather, terrain, geographical location, and individual use, the maintenance intervals may need to be shortened.

WARNING

EWA10322

Failure to properly maintain the vehicle or performing maintenance activities incorrectly may increase your risk of injury or death during service or while using the vehicle. If you are not familiar with vehicle service, have a Yamaha dealer perform service.

EWA15123

WARNING

Turn off the engine when performing maintenance unless otherwise specified.

- **A running engine has moving parts that can catch on body parts or clothing and electrical parts that can cause shocks or fires.**
- **Running the engine while servicing can lead to eye injury, burns, fire, or carbon monoxide poisoning – possibly leading to death. See page 2-3 for more information about carbon monoxide.**

EWA15461

WARNING

Brake discs, calipers, drums, and linings can become very hot during use. To avoid possible burns, let brake components cool before touching them.

EAU17382

Owner's tool kit

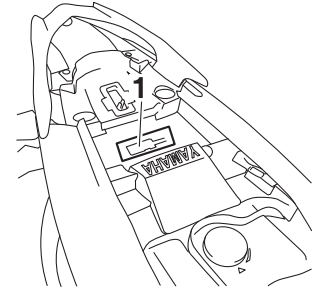

1. Owner's tool kit

The owner's tool kit is located under the seat. (See page 4-12.)

The service information included in this manual and the tools provided in the owner's tool kit are intended to assist you in the performance of preventive maintenance and minor repairs. However, additional tools such as a torque wrench may be necessary to perform certain maintenance work correctly.

TIP

If you do not have the tools or experience required for a particular job, have a Yamaha dealer perform it for you.

PERIODIC MAINTENANCE AND ADJUSTMENT

EAUJ0621

- TIP**
- The annual checks must be performed every year, except if a kilometer-based maintenance is performed instead.
 - From 20000 km, repeat the maintenance intervals starting from 4000 km.
 - Items marked with an asterisk should be performed by a Yamaha dealer as they require special tools, data and technical skills.

EAU5561

Periodic maintenance chart for the emission control system

NO.	ITEM	CHECK OR MAINTENANCE JOB	ODOMETER READING (whichever comes first)					ANNUAL CHECK
			1000 km or 2 months	4000 km or 6 months	8000 km or 10 months	12000 km or 14 months	16000 km or 18 months	
1	* Fuel line	<ul style="list-style-type: none"> • Check fuel hose for cracks or damage. 		√	√	√	√	√
2	* Fuel filter	<ul style="list-style-type: none"> • Check condition. • Replace if necessary. 	Every 12000 km (7500 mi)					
3	Spark plug	<ul style="list-style-type: none"> • Check condition. • Clean and regap. 		√	√	√	√	
		<ul style="list-style-type: none"> • Replace. 	Every 8000 km (5000 mi)					
4	* Valves	<ul style="list-style-type: none"> • Check valve clearance. • Adjust if necessary. 			√		√	
5	* Fuel injection	<ul style="list-style-type: none"> • Check engine idle speed. 	√	√	√	√	√	√
6	* Exhaust system	<ul style="list-style-type: none"> • Check for leakage. • Tighten if necessary. • Replace gasket(s) if necessary. 		√	√	√	√	√

PERIODIC MAINTENANCE AND ADJUSTMENT

EAU55575

General maintenance and lubrication chart

NO.	ITEM	CHECK OR MAINTENANCE JOB	ODOMETER READING (whichever comes first)					ANNUAL CHECK
			1000 km or 2 months	4000 km or 6 months	8000 km or 10 months	12000 km or 14 months	16000 km or 18 months	
1	Air filter element	• Clean.	√	√	√	√	√	√
		• Replace.	Every 12000 km (7500 mi)					
2	* Battery	• Check voltage. • Charge if necessary.	√	√	√	√	√	√
3	Clutch	• Check operation. • Adjust.	√	√	√	√	√	
4	* Front brake	• Check operation, fluid level and vehicle for fluid leakage.	√	√	√	√	√	√
		• Replace brake pads.	Whenever worn to the limit					
5	* Rear brake	• Check operation, fluid level and vehicle for fluid leakage.	√	√	√	√	√	√
		• Replace brake pads.	Whenever worn to the limit					
6	* Brake hose	• Check for cracks or damage. • Check for correct routing and clamping.		√	√	√	√	√
		• Replace.	Every 4 years					
7	* Brake fluid	• Replace.	Every 2 years					
8	* Wheels	• Check runout and for damage. • Replace if necessary.		√	√	√	√	

7

PERIODIC MAINTENANCE AND ADJUSTMENT

NO.	ITEM	CHECK OR MAINTENANCE JOB	ODOMETER READING (whichever comes first)					ANNUAL CHECK
			1000 km or 2 months	4000 km or 6 months	8000 km or 10 months	12000 km or 14 months	16000 km or 18 months	
9	* Tires	<ul style="list-style-type: none"> • Check tread depth and for damage. • Replace if necessary. • Check air pressure. • Correct if necessary. 		√	√	√	√	√
10	* Wheel bearings	<ul style="list-style-type: none"> • Check bearings for looseness or damage. 		√	√	√	√	
11	* Swingarm	<ul style="list-style-type: none"> • Check operation and for excessive play. 		√	√	√	√	
		<ul style="list-style-type: none"> • Lubricate with lithium-soap-based grease. 	Every 24000 km (15000 mi)					
12	Drive chain	<ul style="list-style-type: none"> • Check chain slack, alignment and condition. • Adjust and lubricate chain with a special O-ring chain lubricant thoroughly. 	Every 1000 km (600 mi) and after washing the motorcycle, riding in the rain or riding in wet areas					
13	* Steering bearings	<ul style="list-style-type: none"> • Check bearing play and steering for roughness. 	√	√	√	√	√	
		<ul style="list-style-type: none"> • Lubricate with lithium-soap-based grease. 	Every 24000 km (15000 mi)					
14	* Chassis fasteners	<ul style="list-style-type: none"> • Make sure that all nuts, bolts and screws are properly tightened. 		√	√	√	√	√
15	Brake lever pivot shaft	<ul style="list-style-type: none"> • Lubricate with silicone grease. 		√	√	√	√	√
16	Brake pedal pivot shaft	<ul style="list-style-type: none"> • Lubricate with silicone grease. 		√	√	√	√	√

PERIODIC MAINTENANCE AND ADJUSTMENT

NO.	ITEM	CHECK OR MAINTENANCE JOB	ODOMETER READING (whichever comes first)					ANNUAL CHECK
			1000 km or 2 months	4000 km or 6 months	8000 km or 10 months	12000 km or 14 months	16000 km or 18 months	
17	Clutch lever pivot shaft	<ul style="list-style-type: none"> Lubricate with lithium-soap-based grease. 		√	√	√	√	√
18	Shift pedal pivot shaft	<ul style="list-style-type: none"> Lubricate with lithium-soap-based grease. 		√	√	√	√	√
19	Sidestand, center-stand	<ul style="list-style-type: none"> Check operation. Lubricate with lithium-soap-based grease. 		√	√	√	√	√
20 *	Front fork	<ul style="list-style-type: none"> Check operation and for oil leakage. 		√	√	√	√	
21 *	Shock absorber assembly	<ul style="list-style-type: none"> Check operation and shock absorber for oil leakage. 		√	√	√	√	
22	Engine oil	<ul style="list-style-type: none"> Change. Check oil level and vehicle for oil leakage. 	√	√	√	√	√	√
23	Engine oil filter element	<ul style="list-style-type: none"> Replace. 	√		√		√	
24 *	Cooling system	<ul style="list-style-type: none"> Check coolant level and vehicle for coolant leakage. 		√	√	√	√	√
		<ul style="list-style-type: none"> Change with Yamaha genuine coolant. 	Every 3 years					
25 *	Front and rear brake switches	<ul style="list-style-type: none"> Check operation. 	√	√	√	√	√	√
26	Moving parts and cables	<ul style="list-style-type: none"> Lubricate. 		√	√	√	√	√

PERIODIC MAINTENANCE AND ADJUSTMENT

NO.	ITEM	CHECK OR MAINTENANCE JOB	ODOMETER READING (whichever comes first)					ANNUAL CHECK
			1000 km or 2 months	4000 km or 6 months	8000 km or 10 months	12000 km or 14 months	16000 km or 18 months	
27	*	Throttle grip		√	√	√	√	√
28	*	Lights, signals and switches	√	√	√	√	√	√

EAU18662

TIP

- The air filter needs more frequent service if you are riding in unusually wet or dusty areas.
- Hydraulic brake service
 - Regularly check and, if necessary, correct the brake fluid level.
 - Every two years replace the internal components of the brake master cylinder and caliper, and change the brake fluid.
 - Replace the brake hoses every four years and if cracked or damaged.

PERIODIC MAINTENANCE AND ADJUSTMENT

EAU18724

Removing and installing the cowling and panels

The cowling and panels shown need to be removed to perform some of the maintenance jobs described in this chapter. Refer to this section each time the cowling or a panel needs to be removed and installed.

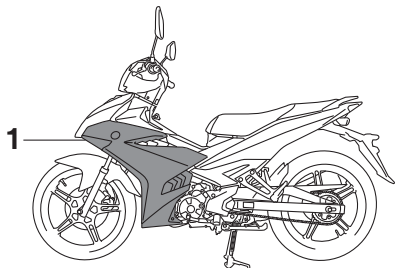

1. Panel A

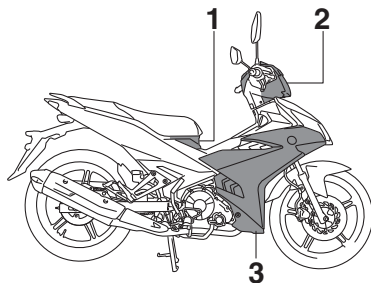

1. Panel C
2. Cowling A
3. Panel B

Cowling A

To remove the cowling

Remove the screws, and then take the cowling off.

EAU18791

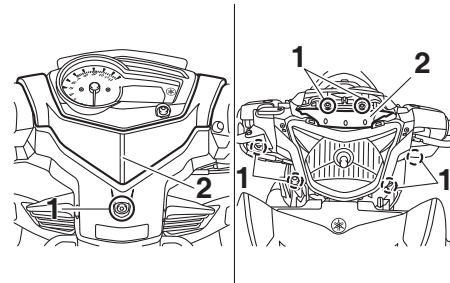

1. Screw
2. Cowling A

To install the cowling

Place the cowling in the original position, and then install the screws.

EAU0521

Panels A and B

To remove a panel

Remove the screws, and then pull the panel off as shown.

PERIODIC MAINTENANCE AND ADJUSTMENT

EAUT1837

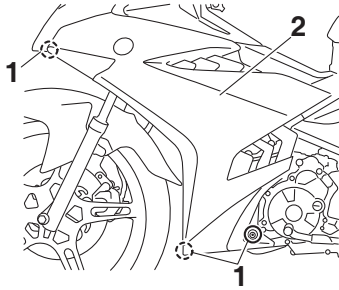

1. Screw
2. Panel A

To install a panel

Place the panel in the original position, and then install the screws.

Panel C

To remove the panel

1. Open the seat. (See page 4-12.)
2. Remove the screws, and then pull the panel off as shown.

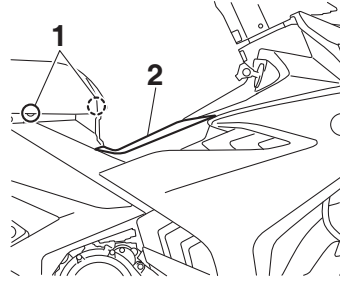

1. Screw
2. Panel C

To install the panel

1. Place the panel in the original position, and then install the screws.
2. Close the seat.

Checking the spark plug

The spark plug is an important engine component, which is easy to check. Since heat and deposits will cause any spark plug to slowly erode, the spark plug should be removed and checked in accordance with the periodic maintenance and lubrication chart. In addition, the condition of the spark plug can reveal the condition of the engine.

To remove the spark plug

1. Place the vehicle on the center-stand.
2. Remove panel B. (See page 7-7.)
3. Remove the spark plug cap.

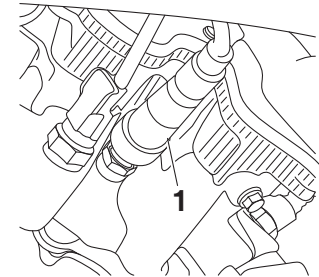

1. Spark plug cap

PERIODIC MAINTENANCE AND ADJUSTMENT

4. Remove the spark plug as shown, with the spark plug wrench included in the owner's tool kit.

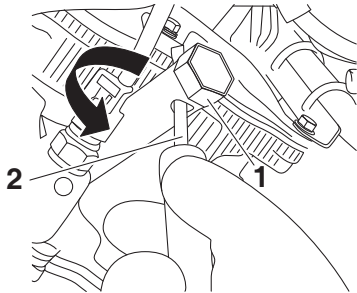

1. Spark plug wrench
2. Screwdriver

7

To check the spark plug

1. Check that the porcelain insulator around the center electrode of the spark plug is a medium-to-light tan (the ideal color when the vehicle is ridden normally).

TIP

If the spark plug shows a distinctly different color, the engine could be operating improperly. Do not attempt to

diagnose such problems yourself. Instead, have a Yamaha dealer check the vehicle.

2. Check the spark plug for electrode erosion and excessive carbon or other deposits, and replace it if necessary.

Specified spark plug:
NGK/CR8E

3. Measure the spark plug gap with a wire thickness gauge and, if necessary, adjust the gap to specification.

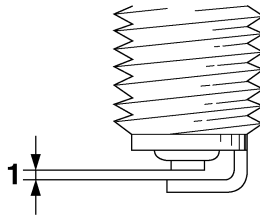

1. Spark plug gap

Spark plug gap:
0.7–0.8 mm (0.031–0.031 in)

To install the spark plug

1. Clean the surface of the spark plug gasket and its mating surface, and then wipe off any grime from the spark plug threads.
2. Install the spark plug with the spark plug wrench, and then tighten it to the specified torque.

Tightening torque:

Spark plug:
13 Nm (1.3 m·kgf, 9.4 ft·lbf)

TIP

If a torque wrench is not available when installing a spark plug, a good estimate of the correct torque is 1/4–1/2 turn past finger tight. However, the spark plug should be tightened to the specified torque as soon as possible.

3. Install the spark plug cap.
4. Install the panel.

PERIODIC MAINTENANCE AND ADJUSTMENT

Engine oil and oil filter element

EAU37574

The engine oil level should be checked before each ride. In addition, the oil must be changed and the oil filter element replaced at the intervals specified in the periodic maintenance and lubrication chart.

To check the engine oil level

1. Place the vehicle on the center-stand. A slight tilt to the side can result in a false reading.
2. Start the engine, warm it up for several minutes, and then turn it off.
3. Wait a few minutes until the oil settles, remove the oil filler cap, wipe the dipstick clean, insert it back into the oil filler hole (without screwing it in), and then remove it again to check the oil level.

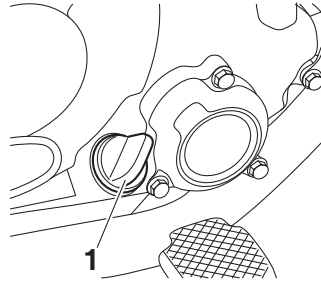

1. Engine oil filler cap

TIP

The engine oil should be between the minimum and maximum level marks.

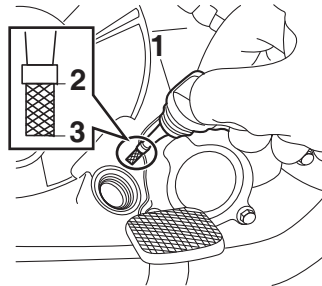

1. Engine oil dipstick
2. Maximum level mark
3. Tip of the engine oil dipstick

4. If the engine oil is at or below the minimum level mark, add sufficient oil of the recommended type to raise it to the correct level.
5. Insert the dipstick into the oil filler hole, and then tighten the oil filler cap.

To change the engine oil (with or without oil filter element replacement)

1. Start the engine, warm it up for several minutes, and then turn it off.
2. Place an oil pan under the engine to collect the used oil.
3. Remove the engine oil filler cap and drain bolt along with the O-ring, compression spring, and engine oil strainer, to drain the oil from the crankcase. **NOTICE:** When removing the engine oil drain bolt, the O-ring, compression spring, and oil strainer will fall out. Take care not to lose these parts. [ECA11002]

PERIODIC MAINTENANCE AND ADJUSTMENT

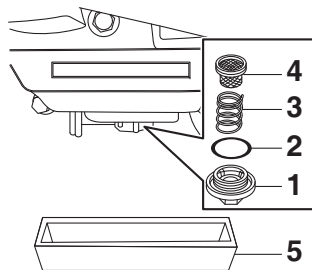

1. Engine oil drain bolt
2. O-ring
3. Compression spring
4. Strainer
5. Oil pan

7

TIP _____
Check the O-ring for damage and replace it if necessary.

4. Clean the engine oil strainer with solvent.

TIP _____
Skip steps 5–7 if the oil filter element is not being replaced.

5. Remove the oil filter element cover by removing the bolts.

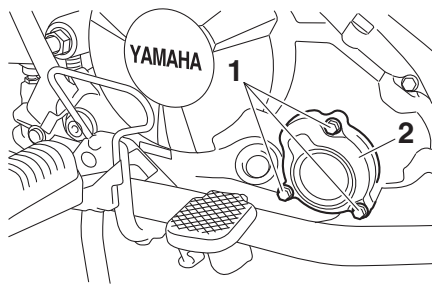

1. Bolt
2. Oil filter element cover

6. Remove and replace the oil filter element and O-ring.

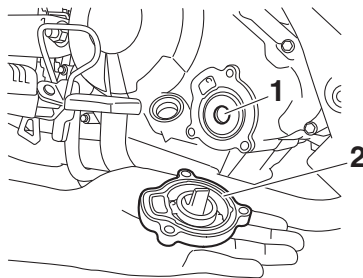

1. Oil filter element
2. O-ring

7. Install the oil filter element cover by installing the bolts, then tightening them to the specified torque.

Tightening torque:

Oil filter element cover bolt:
10 Nm (1.0 m·kgf, 7.2 ft·lbf)

TIP _____

Make sure that the O-ring is properly seated.

8. Install the engine oil strainer, compression spring, O-ring and engine oil drain bolt, and then tighten the drain bolt to the specified torque. **NOTICE: Before installing the engine oil drain bolt, do not forget to install the O-ring, compression spring, and oil strainer in position.** [ECA10422]

Tightening torque:

Engine oil drain bolt:
32 Nm (3.2 m·kgf, 23 ft·lbf)

PERIODIC MAINTENANCE AND ADJUSTMENT

9. Refill with the specified amount of the recommended engine oil, and then install and tighten the oil filler cap.

Recommended engine oil:

See page 9-1.

Oil quantity:

With oil filter element replacement:

1.00 L (1.06 US qt, 0.88 Imp.qt)

Without oil filter element replacement:

0.95 L (1.00 US qt, 0.84 Imp.qt)

TIP

Be sure to wipe off spilled oil on any parts after the engine and exhaust system have cooled down.

ECA11621

NOTICE

- In order to prevent clutch slippage (since the engine oil also lubricates the clutch), do not mix any chemical additives. Do not use oils with a diesel specification of “CD” or oils of a higher quality than specified. In

addition, do not use oils labeled “ENERGY CONSERVING II” or higher.

- Make sure that no foreign material enters the crankcase.

10. Start the engine, and then let it idle for several minutes while checking it for oil leakage. If oil is leaking, immediately turn the engine off and check for the cause.
11. Turn the engine off, and then check the oil level and correct it if necessary.

Coolant

EAU20071

The coolant level should be checked before each ride. In addition, the coolant must be changed at the intervals specified in the periodic maintenance and lubrication chart.

To check the coolant level

EAU40047

1. Place the vehicle on the centerstand.

TIP

- The coolant level must be checked on a cold engine since the level varies with engine temperature.
- Make sure that the vehicle is positioned straight up when checking the coolant level. A slight tilt to the side can result in an incorrect reading.

2. Check the coolant level in the coolant reservoir.

TIP

The coolant should be between the minimum and maximum level marks.

PERIODIC MAINTENANCE AND ADJUSTMENT

EAU33032

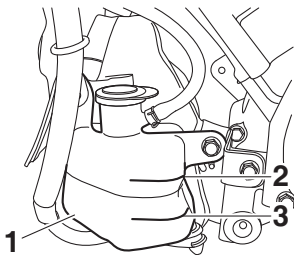

1. Coolant reservoir
2. Maximum level mark
3. Minimum level mark

If water has been used instead of coolant, replace it with coolant as soon as possible, otherwise the cooling system will not be protected against frost and corrosion. If water has been added to the coolant, have a Yamaha dealer check the anti-freeze content of the coolant as soon as possible, otherwise the effectiveness of the coolant will be reduced. [ECA10473]

Changing the coolant

The coolant must be changed at the intervals specified in the periodic maintenance and lubrication chart. Have a Yamaha dealer change the coolant. **WARNING!** Never attempt to remove the radiator cap when the engine is hot. [EWA10382]

3. If the coolant is at or below the minimum level mark, remove panel A to access the coolant reservoir. (See page 7-7.)
4. Remove the coolant reservoir cap, add coolant to the maximum level mark, and then install the reservoir cap. **WARNING!** Remove only the coolant reservoir cap. Never attempt to remove the radiator cap when the engine is hot.

[EWA15162]

NOTICE: If coolant is not available, use distilled water or soft tap water instead. Do not use hard water or salt water since it is harmful to the engine.

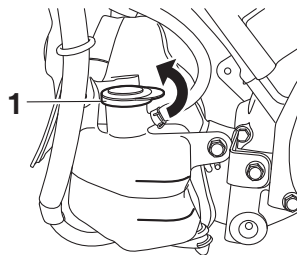

1. Coolant reservoir cap

Coolant reservoir capacity (up to the maximum level mark):
0.28 L (0.30 US qt, 0.25 Imp.qt)

5. Install the panel.

PERIODIC MAINTENANCE AND ADJUSTMENT

EAU65831

Cleaning the air filter element

The air filter element should be cleaned at the intervals specified in the periodic maintenance and lubrication chart. Clean the air filter element more frequently if you are riding in unusually wet or dusty areas.

1. Remove panel C. (See page 7-7.)
2. Remove the seat by pulling the seat pin out as shown.

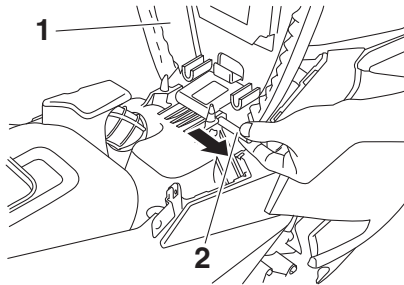

1. Seat
2. Pin

3. Remove the air filter case cover by removing the screws and bolts, and then pull the air filter element out.

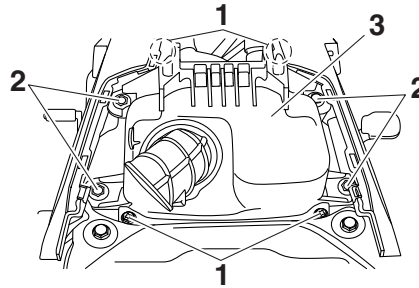

1. Screw
2. Bolt
3. Air filter case cover

4. Lightly tap the air filter element to remove the most of the dust and dirt, and then blow the remaining dirt out with compressed air as shown. If the air filter element is damaged, replace it.

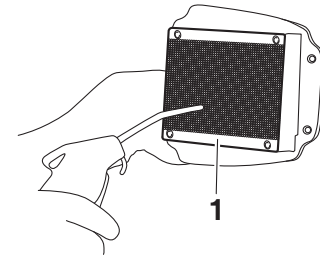

1. Air filter element

5. Insert the air filter element into the air filter case. **NOTICE: Make sure that the air filter element is properly seated in the air filter case. The engine should never be operated without the air filter element installed, otherwise the piston(s) and/or cylinder(s) may become excessively worn.**

[ECA10482]

6. Install the air filter case cover by installing the screws and bolts.

TIP

If dust or water collects in the air filter check hose, remove the clamp, and then remove the plug to drain the hose.

PERIODIC MAINTENANCE AND ADJUSTMENT

7. Install the seat by installing the seat pin.
8. Install the panel.

EAU34302

Adjusting the engine idling speed

The engine idling speed must be checked and, if necessary, adjusted as follows at the intervals specified in the periodic maintenance and lubrication chart.

The engine should be warm before making this adjustment.

Check the engine idling speed and, if necessary, adjust it to specification by turning the idle adjusting screw. To increase the engine idling speed, turn the screw in direction (a). To decrease the engine idling speed, turn the screw in direction (b).

Engine idling speed:
1300–1500 r/min

TIP

If the specified idling speed cannot be obtained as described above, have a Yamaha dealer make the adjustment.

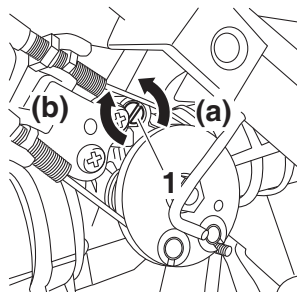

1. Idle adjusting screw

EAU48433

Adjusting the throttle grip free play

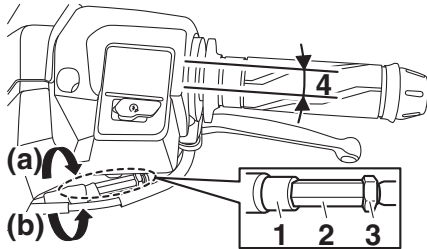

1. Rubber cover
2. Throttle grip free play adjusting nut
3. Locknut
4. Throttle grip free play

The throttle grip free play should measure 3.0–7.0 mm (0.12–0.28 in) at the inner edge of the throttle grip. Periodically check the throttle grip free play and, if necessary, adjust it as follows.

TIP

The engine idling speed must be correctly adjusted before checking and adjusting the throttle grip free play.

1. Slide the rubber cover back.
2. Loosen the locknut.

3. To increase the throttle grip free play, turn the adjusting nut in direction (a). To decrease the throttle grip free play, turn the adjusting nut in direction (b).
4. Tighten the locknut and then slide the rubber cover to its original position.

Valve clearance

EAU21402

The valve clearance changes with use, resulting in improper air-fuel mixture and/or engine noise. To prevent this from occurring, the valve clearance must be adjusted by a Yamaha dealer at the intervals specified in the periodic maintenance and lubrication chart.

PERIODIC MAINTENANCE AND ADJUSTMENT

EAUJ0511

Tires

Tires are the only contact between the vehicle and the road. Safety in all conditions of riding depends on a relatively small area of road contact. Therefore, it is essential to maintain the tires in good condition at all times and replace them at the appropriate time with the specified tires.

Tire air pressure

The tire air pressure should be checked and, if necessary, adjusted before each ride.

EWA10504



WARNING

Operation of this vehicle with improper tire pressure may cause severe injury or death from loss of control.

- The tire air pressure must be checked and adjusted on cold tires (i.e., when the temperature of the tires equals the ambient temperature).
- The tire air pressure must be adjusted in accordance with the riding speed and with the total

weight of rider, passenger, cargo, and accessories approved for this model.

Tire air pressure (measured on cold tires):

- Front (1 person):
200 kPa (2.00 kgf/cm², 29 psi)
- Rear (1 person):
225 kPa (2.25 kgf/cm², 33 psi)
- Front (2 persons):
200 kPa (2.00 kgf/cm², 29 psi)
- Rear (2 persons):
225 kPa (2.25 kgf/cm², 33 psi)

Maximum load*:

151 kg (333 lb)

* Total weight of rider, passenger, cargo and accessories

EWA10512



Never overload your vehicle. Operation of an overloaded vehicle could cause an accident.

Tire inspection

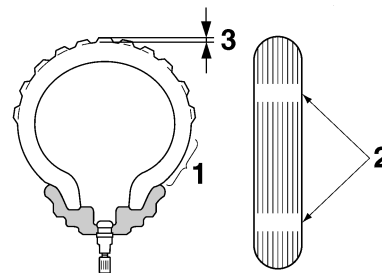

1. Tire sidewall
2. Tire wear indicator
3. Tire tread depth

The tires must be checked before each ride. If a tire tread shows crosswise lines (minimum tread depth), if the tire has a nail or glass fragments in it, or if the sidewall is cracked, contact a Yamaha dealer immediately and have the tire replaced.

Minimum tire tread depth (front and rear):

1.0 mm (0.04 in)

PERIODIC MAINTENANCE AND ADJUSTMENT

EWA10523

EWA10462

EAU21963

WARNING

- It is dangerous to ride with a worn-out tire. When a tire tread begins to show crosswise lines, have a Yamaha dealer replace the tire immediately. Brakes, tires and related wheel parts replacement should also be left to a Yamaha dealer.
- Ride at moderate speeds after changing a tire since the tire surface must first be “broken in” for it to develop its optimal characteristics.

Tire information

This model is equipped with tubeless tires and tire air valves.

Tires age, even if they have not been used or have only been used occasionally. Cracking of the tread and sidewall rubber, sometimes accompanied by carcass deformation, is an evidence of ageing. Old and aged tires shall be checked by tire specialists to ascertain their suitability for further use.

WARNING

The front and rear tires should be of the same make and design, otherwise the handling characteristics of the vehicle may be different, which could lead to an accident.

After extensive tests, only the tires listed below have been approved for this model by Yamaha.

Front tire:

Size:

70/90-17M/C 38P

Manufacturer/model:
IRC/NF67

Rear tire:

Size:

120/70-17M/C 58P

Manufacturer/model:
IRC/NF67

Cast wheels

To maximize the performance, durability, and safe operation of your vehicle, note the following points regarding the specified wheels.

- The wheel rims should be checked for cracks, bends, warpage or other damage before each ride. If any damage is found, have a Yamaha dealer replace the wheel. Do not attempt even the smallest repair to the wheel. A deformed or cracked wheel must be replaced.
- The wheel should be balanced whenever either the tire or wheel has been changed or replaced. An unbalanced wheel can result in poor performance, adverse handling characteristics, and a shortened tire life.

PERIODIC MAINTENANCE AND ADJUSTMENT

Adjusting the clutch lever free play

EAU65840

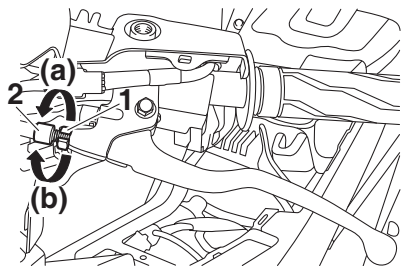

1. Locknut
2. Clutch lever free play adjusting bolt

7

The clutch lever free play should measure 8.0–12.0 mm (0.31–0.47 in) as shown. Periodically check the clutch lever free play and, if necessary, adjust it as follows.

1. Remove cowling A. (See page 7-7.)
2. Loosen the locknut.
3. To increase the clutch lever free play, turn the clutch lever free play adjusting bolt in direction (a). To decrease the clutch lever free play, turn the adjusting bolt in direction (b).

TIP _____
If the specified clutch lever free play could be obtained as described above, skip steps 4–7.

4. Fully turn the adjusting bolt at the clutch lever in direction (a) to loosen the clutch cable.
5. Loosen the locknut at the crankcase.

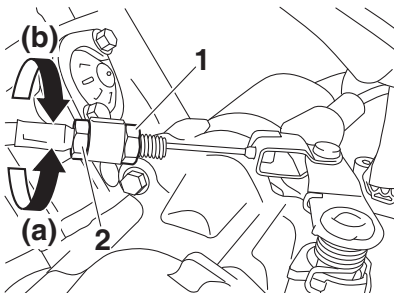

1. Locknut
2. Clutch lever free play adjusting nut

6. To increase the clutch lever free play, turn the clutch lever free play adjusting nut in direction (a). To decrease the clutch lever free play, turn the adjusting nut in direction (b).

7. Tighten the locknut at the crankcase.
8. Tighten the locknut at the clutch lever.
9. Install the cowling.

PERIODIC MAINTENANCE AND ADJUSTMENT

Checking the brake lever free play

EAU37914

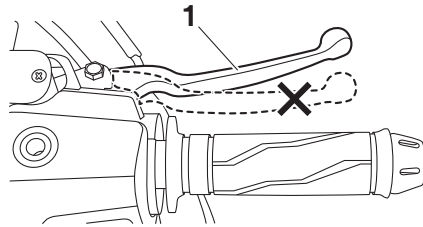

1. Front brake lever

There should be no free play at the brake lever end. If there is free play, have a Yamaha dealer inspect the brake system.

EWA14212

! WARNING

A soft or spongy feeling in the brake lever can indicate the presence of air in the hydraulic system. If there is air in the hydraulic system, have a Yamaha dealer bleed the system before operating the vehicle. Air in the hydraulic system will diminish the

braking performance, which may result in loss of control and an accident.

Checking the shift pedal

EAU44821

The operation of the shift pedal should be checked before each ride. If operation is not smooth, have a Yamaha dealer check the vehicle.

PERIODIC MAINTENANCE AND ADJUSTMENT

Brake light switches

EAU22274

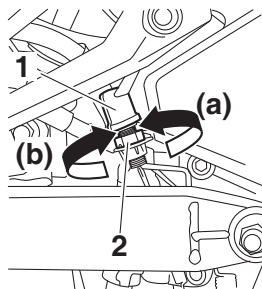

1. Rear brake light switch
2. Rear brake light switch adjusting nut

The brake light, which is activated by the brake pedal and brake lever, should come on just before braking takes effect. If necessary, adjust the rear brake light switch as follows, but the front brake light switch should be adjusted by a Yamaha dealer.

Turn the rear brake light switch adjusting nut while holding the rear brake light switch in place. To make the brake light come on earlier, turn the adjusting nut in direction (a). To make the brake light come on later, turn the adjusting nut in direction (b).

Checking the front and rear brake pads

EAU22393

The front and rear brake pads must be checked for wear at the intervals specified in the periodic maintenance and lubrication chart.

Front brake pads

EAU22432

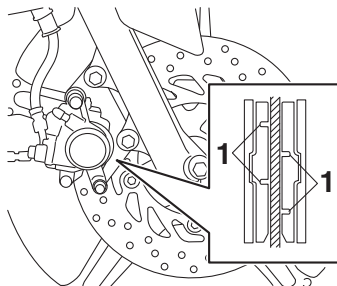

1. Brake pad wear indicator groove

Each front brake pad is provided with wear indicator grooves, which allow you to check the brake pad wear without having to disassemble the brake. To check the brake pad wear, check the wear indicator grooves. If a brake pad has worn to the point that the wear

indicator grooves have almost disappeared, have a Yamaha dealer replace the brake pads as a set.

Rear brake pads

EAU22501

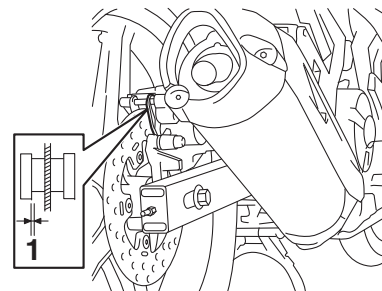

1. Lining thickness

Check each rear brake pad for damage and measure the lining thickness. If a brake pad is damaged or if the lining thickness is less than 1.5 mm (0.06 in), have a Yamaha dealer replace the brake pads as a set.

PERIODIC MAINTENANCE AND ADJUSTMENT

Checking the brake fluid level ^{EAUW0530}

Before riding, check that the brake fluid is above the minimum level mark. Check the brake fluid level with the top of the reservoir level. Replenish the brake fluid if necessary.

Front brake

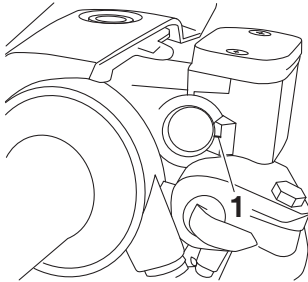

1. Minimum level mark

Rear brake

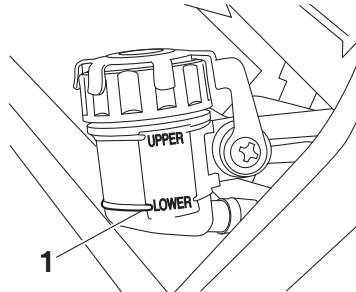

1. Minimum level mark

Specified brake fluid:
DOT 3 or DOT 4

EWA15981

! WARNING

Improper maintenance can result in loss of braking ability. Observe these precautions:

- Insufficient brake fluid may allow air to enter the brake system, reducing braking performance.
- Clean the filler cap before removing. Use only DOT 3 or DOT 4 brake fluid from a sealed container.

- Use only the specified brake fluid; otherwise, the rubber seals may deteriorate, causing leakage.
- Refill with the same type of brake fluid. Adding a brake fluid other than DOT 3 or DOT 4 may result in a harmful chemical reaction.
- Be careful that water does not enter the brake fluid reservoir when refilling. Water will significantly lower the boiling point of the fluid and may result in vapor lock.

NOTICE

Brake fluid may damage painted surfaces or plastic parts. Always clean up spilled fluid immediately.

As the brake pads wear, it is normal for the brake fluid level to gradually go down. A low brake fluid level may indicate worn brake pads and/or brake system leakage; therefore, be sure to check the brake pads for wear and the brake system for leakage. If the brake

ECA17641

PERIODIC MAINTENANCE AND ADJUSTMENT

fluid level goes down suddenly, have a Yamaha dealer check the cause before further riding.

Changing the brake fluid

EAU22724

Have a Yamaha dealer change the brake fluid at the intervals specified in the periodic maintenance and lubrication chart. In addition, have the oil seals of the brake master cylinder and caliper as well as the brake hose replaced at the intervals listed below or whenever they are damaged or leaking.

- Oil seals: Replace every two years.
- Brake hose: Replace every four years.

Drive chain slack

EAU22762

The drive chain slack should be checked before each ride and adjusted if necessary.

To check the drive chain slack

EAU22796

1. Place the motorcycle on the centerstand.
2. Shift the transmission into the neutral position.
3. Measure the drive chain slack as shown.

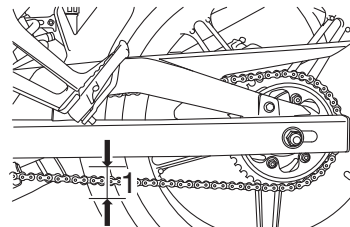

1. Drive chain slack

Drive chain slack:
20.0–30.0 mm (0.79–1.18 in)

4. If the drive chain slack is incorrect, adjust it as follows.

PERIODIC MAINTENANCE AND ADJUSTMENT

EAU66611

To adjust the drive chain slack

Consult a Yamaha dealer before adjusting the drive chain slack.

1. Loosen the locknut at each end of the swingarm, and then loosen the axle nut and the brake caliper bracket bolt.
2. To tighten the drive chain, turn the drive chain slack adjusting nut at each end of the swingarm in direction (a). To loosen the drive chain, turn the adjusting nut at each end of the swingarm in direction (b), and then push the rear wheel forward. **NOTICE: Improper drive chain slack will overload the engine as well as other vital parts of the motorcycle and can lead to chain slippage or breakage. To prevent this from occurring, keep the drive chain slack within the specified limits.** [ECA10572]

TIP

Using the alignment marks on each drive chain puller, make sure that both chain pullers are in the same position for proper wheel alignment.

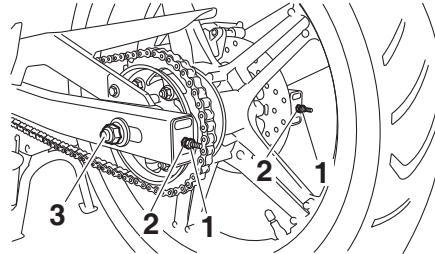

1. Locknut
2. Drive chain slack adjusting nut
3. Axle nut

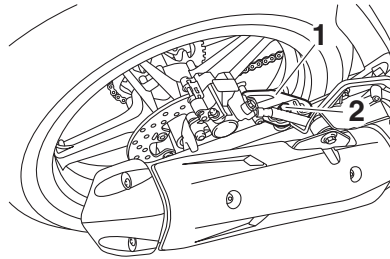

1. Brake caliper bracket
2. Brake caliper bracket bolt

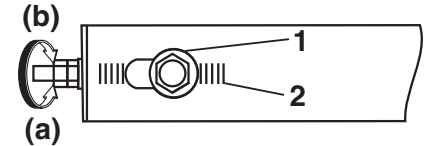

ZAUN0630

1. Washer
2. Alignment marks

3. Tighten the axle nut, the brake caliper bracket bolt, and then tighten the locknuts to the specified torques.

Tightening torques:

Axle nut:

90 Nm (9.0 m·kgf, 65 ft·lbf)

Brake caliper bracket:

39 Nm (3.9 m·kgf, 28 ft·lbf)

Locknut:

7 Nm (0.7 m·kgf, 5.1 ft·lbf)

4. Make sure that the drive chain pullers are in the same position, the drive chain slack is correct, and the drive chain moves smoothly.

PERIODIC MAINTENANCE AND ADJUSTMENT

Cleaning and lubricating the drive chain

EAU23018

The drive chain must be cleaned and lubricated at the intervals specified in the periodic maintenance and lubrication chart, otherwise it will quickly wear out, especially when riding in dusty or wet areas. Service the drive chain as follows.

ECA10584

NOTICE

The drive chain must be lubricated after washing the motorcycle, riding in the rain or riding in wet areas.

1. Remove all dirt and mud from the drive chain with a brush or cloth.

TIP

For a thorough cleaning, have a Yamaha dealer remove the drive chain and soak it in solvent.

2. Spray Yamaha chain lubricant or other suitable chain lubricant on the entire chain, making sure that all side plates and rollers have been sufficiently oiled.

Checking and lubricating the cables

EAU23098

The operation of all control cables and the condition of the cables should be checked before each ride, and the cables and cable ends should be lubricated if necessary. If a cable is damaged or does not move smoothly, have a Yamaha dealer check or replace it. **WARNING! Damage to the outer housing of cables may result in internal rusting and cause interference with cable movement. Replace damaged cables as soon as possible to prevent unsafe conditions.** [EWA10712]

Recommended lubricant:

Yamaha cable lubricant or other suitable cable lubricant

Checking and lubricating the throttle grip and cable

EAU23115

The operation of the throttle grip should be checked before each ride. In addition, the cable should be lubricated by a Yamaha dealer at the intervals specified in the periodic maintenance chart.

The throttle cable is equipped with a rubber cover. Make sure that the cover is securely installed. Even though the cover is installed correctly, it does not completely protect the cable from water entry. Therefore, use care not to pour water directly onto the cover or cable when washing the vehicle. If the cable or cover becomes dirty, wipe clean with a moist cloth.

PERIODIC MAINTENANCE AND ADJUSTMENT

Checking and lubricating the brake and clutch levers EAU23144

The operation of the brake and clutch levers should be checked before each ride, and the lever pivots should be lubricated if necessary.

Brake lever

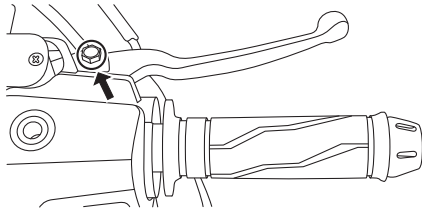

Clutch lever

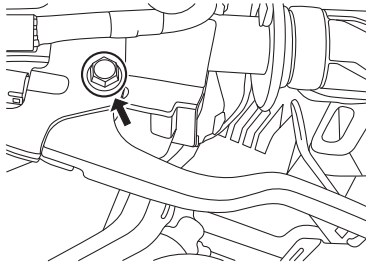

Recommended lubricants:

Brake lever:

Silicone grease

Clutch lever:

Lithium-soap-based grease

Checking and lubricating the brake pedal EAU23185

The operation of the brake pedal should be checked before each ride, and the pedal pivot should be lubricated if necessary.

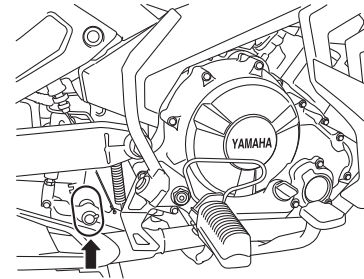

Recommended lubricant:

Lithium-soap-based grease

PERIODIC MAINTENANCE AND ADJUSTMENT

Checking and lubricating the centerstand and sidestand

EAU23215

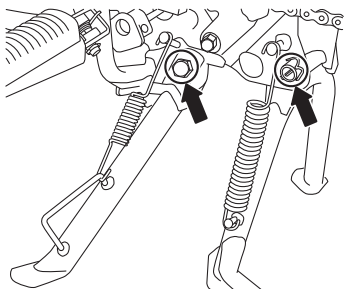

The operation of the centerstand and sidestand should be checked before each ride, and the pivots and metal-to-metal contact surfaces should be lubricated if necessary.

EWA10742

WARNING

If the centerstand or sidestand does not move up and down smoothly, have a Yamaha dealer check or repair it. Otherwise, the centerstand or sidestand could contact the ground and distract the operator, resulting in a possible loss of control.

Recommended lubricant:
Lithium-soap-based grease

Lubricating the swingarm pivots

EAUM1653

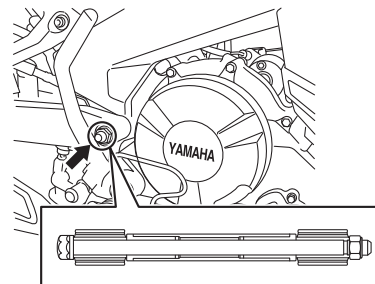

The swingarm pivots must be lubricated by a Yamaha dealer at the intervals specified in the periodic maintenance and lubrication chart.

Recommended lubricant:
Lithium-soap-based grease

EAU23273

Checking the front fork

The condition and operation of the front fork must be checked as follows at the intervals specified in the periodic maintenance and lubrication chart.

To check the condition

Check the inner tubes for scratches, damage and excessive oil leakage.

To check the operation

1. Place the vehicle on a level surface and hold it in an upright position. **WARNING! To avoid injury, securely support the vehicle so there is no danger of it falling over.** [EWA10752]
2. While applying the front brake, push down hard on the handlebars several times to check if the front fork compresses and rebounds smoothly.

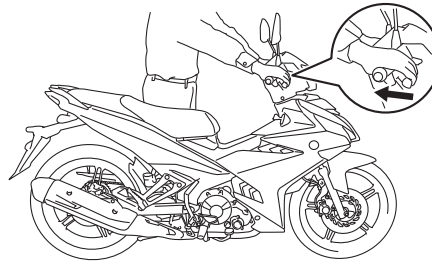

ECA10591

NOTICE

If any damage is found or the front fork does not operate smoothly, have a Yamaha dealer check or repair it.

EAU45512

Checking the steering

Worn or loose steering bearings may cause danger. Therefore, the operation of the steering must be checked as follows at the intervals specified in the periodic maintenance and lubrication chart.

1. Place the vehicle on the centerstand. **WARNING! To avoid injury, securely support the vehicle so there is no danger of it falling over.** [EWA10752]
2. Hold the lower ends of the front fork legs and try to move them forward and backward. If any free play can be felt, have a Yamaha dealer check or repair the steering.

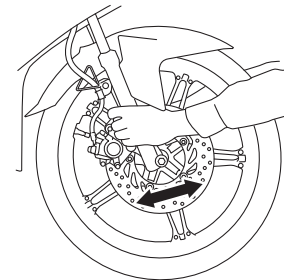

PERIODIC MAINTENANCE AND ADJUSTMENT

Checking the wheel bearings

EAU23292

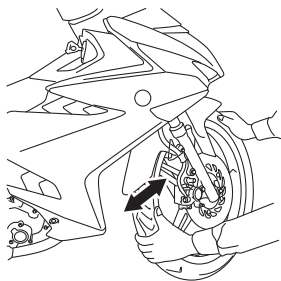

The front and rear wheel bearings must be checked at the intervals specified in the periodic maintenance and lubrication chart. If there is play in the wheel hub or if the wheel does not turn smoothly, have a Yamaha dealer check the wheel bearings.

7

Battery

EAU65852

The battery is located under the seat. (See page 4-12.)

This model is equipped with a VRLA (Valve Regulated Lead Acid) battery. There is no need to check the electrolyte or to add distilled water. However, the battery lead connections need to be checked and, if necessary, tightened.

EWA10761

⚠ WARNING

- **Electrolyte is poisonous and dangerous since it contains sulfuric acid, which causes severe burns. Avoid any contact with skin, eyes or clothing and always shield your eyes when working near batteries. In case of contact, administer the following FIRST AID.**

- **EXTERNAL:** Flush with plenty of water.
- **INTERNAL:** Drink large quantities of water or milk and immediately call a physician.

- **EYES:** Flush with water for 15 minutes and seek prompt medical attention.
- **Batteries produce explosive hydrogen gas. Therefore, keep sparks, flames, cigarettes, etc., away from the battery and provide sufficient ventilation when charging it in an enclosed space.**
- **KEEP THIS AND ALL BATTERIES OUT OF THE REACH OF CHILDREN.**

EWA16091

⚠ WARNING

Remove the battery cover by removing the bolts and the quick fastener screws before servicing the battery. The cover material can conduct electricity. If the cover has not been removed, touching the cover and the battery positive terminal at the same time with a tool will cause a short circuit and sparks.

PERIODIC MAINTENANCE AND ADJUSTMENT

EAU62442

To charge the battery

Have a Yamaha dealer charge the battery as soon as possible if it seems to have discharged. Keep in mind that the battery tends to discharge more quickly if the vehicle is equipped with optional electrical accessories.

ECA16522

NOTICE

To charge a VRLA (Valve Regulated Lead Acid) battery, a special (constant-voltage) battery charger is required. Using a conventional battery charger will damage the battery.

To store the battery

1. If the vehicle will not be used for more than one month, remove the battery, fully charge it, and then place it in a cool, dry place. **NOTICE: When removing the battery, be sure the key is turned to "OFF", then disconnect the negative lead before disconnecting the positive lead.**

[ECA16303]

2. If the battery will be stored for more than two months, check it at least once a month and fully charge it if necessary.
3. Fully charge the battery before installation. **NOTICE: When installing the battery, be sure the key is turned to "OFF", then connect the positive lead before connecting the negative lead.** [ECA16841]
4. After installation, make sure that the battery leads are properly connected to the battery terminals.

ECA16531

NOTICE

Always keep the battery charged. Storing a discharged battery can cause permanent battery damage.

Replacing the fuses

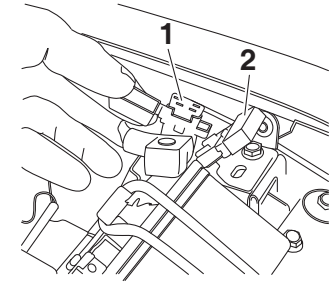

1. Main fuse
2. Sub fuse

The fuse holder is located under the seat. (See page 4-12.)

If a fuse is blown, replace it as follows.

1. Turn the key to "OFF" and turn off all electrical circuits.
2. Remove the blown fuse, and then install a new fuse of the specified amperage. **WARNING! Do not use a fuse of a higher amperage rating than recommended to avoid causing extensive damage to the electrical system and possibly a fire.** [EWA15132]

PERIODIC MAINTENANCE AND ADJUSTMENT

Specified fuses:

- Main fuse:
15.0 A
Sub fuse:
7.5 A

- Turn the key to “ON” and turn on the electrical circuits to check if the devices operate.
- If the fuse immediately blows again, have a Yamaha dealer check the electrical system.

Replacing the headlight bulb

EAU53354

ECA10671

NOTICE

It is advisable to have a Yamaha dealer perform this job.

This model is equipped with a halogen bulb headlight. If the headlight bulb burns out, replace it as follows.

ECA10651

NOTICE

Take care not to damage the following parts:

- **Headlight bulb**

Do not touch the glass part of the headlight bulb to keep it free from oil, otherwise the transparency of the glass, the luminosity of the bulb, and the bulb life will be adversely affected. Thoroughly clean off any dirt and fingerprints on the headlight bulb using a cloth moistened with alcohol or thinner.

- **Headlight lens**

Do not affix any type of tinted film or stickers to the headlight lens.

Do not use a headlight bulb of a wattage higher than specified.

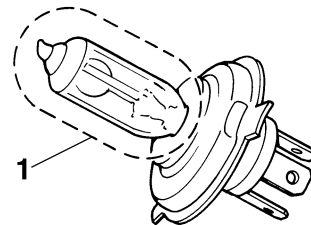

- Do not touch the glass part of the bulb.
 - Place the vehicle on the center-stand.
 - Remove cowling A. (See page 7-7.)
 - Disconnect the headlight coupler, and then remove the headlight bulb cover.
 - Unhook the headlight bulb holder, and then remove the burnt-out bulb.

PERIODIC MAINTENANCE AND ADJUSTMENT

EAU44941

EAU24182

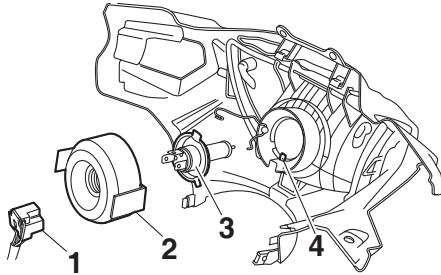

1. Headlight coupler
2. Headlight bulb cover
3. Headlight bulb
4. Headlight bulb holder

5. Place a new headlight bulb into position, and then secure it with the bulb holder.
6. Install the headlight bulb cover, and then connect the coupler.
7. Install the cowling.
8. Have a Yamaha dealer adjust the headlight beam if necessary.

Auxiliary light

This model is equipped with an LED-type auxiliary light.

If the auxiliary light does not come on, have a Yamaha dealer check it.

Tail/brake light

This model is equipped with an LED-type tail/brake light.

If the tail/brake light does not come on, have a Yamaha dealer check it.

PERIODIC MAINTENANCE AND ADJUSTMENT

Replacing a front turn signal light bulb

EAUJ0560

ECA10671

NOTICE

It is advisable to have a Yamaha dealer perform this job.

1. Place the vehicle on the center-stand.
2. Remove panel A and B. (See page 7-7.)
3. Remove the turn signal light bulb socket (together with the bulb) by turning it counterclockwise.

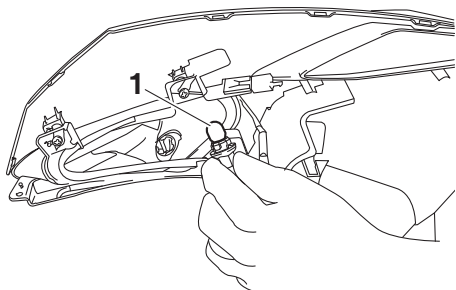

1. Turn signal light bulb
4. Remove the burnt out bulb by pulling it out.
5. Insert a new bulb into the socket.

6. Install the socket (together with the bulb) by turning it clockwise.
7. Install the panels.

Replacing a rear turn signal light bulb

EAUJ1121

1. Remove the rear turn signal lens by removing the screw.

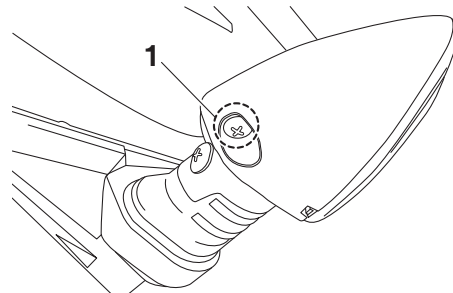

1. Screw

2. Remove the burnt-out bulb by pulling it out.

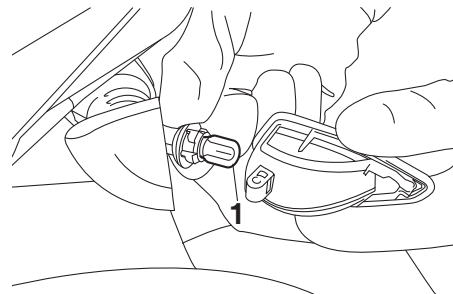

1. Turn signal light bulb

PERIODIC MAINTENANCE AND ADJUSTMENT

3. Insert a new bulb into the socket by pushing it in.

ECAU0081

NOTICE

If a turn signal light bulb of different wattage than recommended is used, the turn signal light flashing may be affected.

4. Install the lens by installing the screw. **NOTICE: Do not over-tighten the screw, otherwise the lens may break.** [ECA11192]

Replacing the license plate light bulb

EAU24314

1. Remove the license plate light unit by removing the screws.

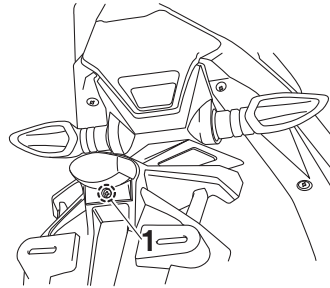

1. Screw

2. Remove the license plate light bulb socket (together with the bulb) by pulling it out.

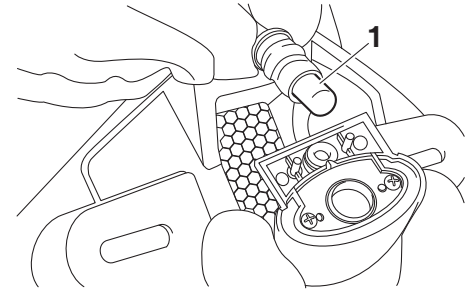

1. License plate light bulb

3. Remove the burnt-out bulb by pulling it out.
4. Insert a new bulb into the socket.
5. Install the socket (together with the bulb) by pushing it in.
6. Install the license plate light unit by installing the screws.

PERIODIC MAINTENANCE AND ADJUSTMENT

Front wheel

EAU24361

wheel and brake disc have been removed, otherwise the brake pads will be forced shut. [ECA11073]

EAU60841

To remove the front wheel

EWA10822



WARNING

To avoid injury, securely support the vehicle so there is no danger of it falling over.

1. Place the motorcycle on the centerstand.
2. Remove the axle nut.

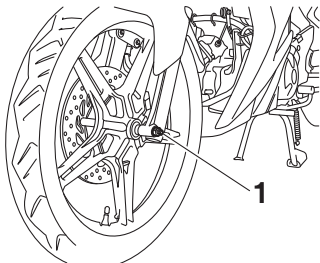

1. Axle nut

3. Pull the wheel axle out, and then remove the wheel. **NOTICE: Do not apply the brake after the**

To install the front wheel

1. Lift the wheel up between the fork legs.
2. Insert the wheel axle, and then install the axle nut.
3. Take the motorcycle off the centerstand so that the front wheel is on the ground.
4. Tighten the axle nut to the specified torque.

Tightening torque:

Axle nut:
40 Nm (4.0 m·kgf, 29 ft·lbf)

TIP

When tightening the axle nut, hold the wheel axle with a wrench to keep it from turning.

5. While applying the front brake, push down hard on the handlebars several times to check if the front fork compresses and rebounds smoothly.

Rear wheel

EAU25081

EAU66621

To remove the rear wheel

EWA10822



WARNING

To avoid injury, securely support the vehicle so there is no danger of it falling over.

1. Loosen the locknut and drive chain slack adjusting nut on each side of the swingarm.
2. Loosen the axle nut and the brake caliper bracket bolt.

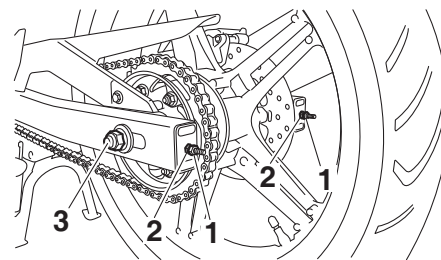

1. Locknut
2. Drive chain slack adjusting nut
3. Axle nut

PERIODIC MAINTENANCE AND ADJUSTMENT

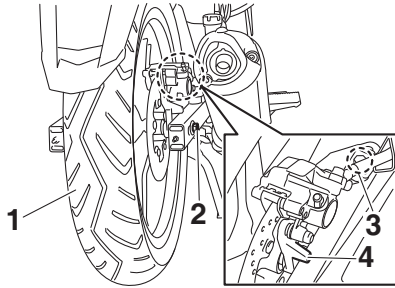

1. Rear wheel
2. Wheel axle
3. Brake caliper bracket bolt
4. Brake caliper bracket

3. Place the motorcycle on the centerstand.
4. Remove the axle nut.
5. Push the wheel forward, and then remove the drive chain from the rear sprocket.

TIP _____
The drive chain does not need to be disassembled in order to remove and install the rear wheel.

6. While supporting the brake caliper and slightly lifting the wheel, pull the wheel axle out.

TIP _____
A rubber mallet may be useful to tap the wheel axle out.

7. Remove the wheel. **NOTICE: Do not apply the brake after the wheel and brake disc have been removed, otherwise the brake pads will be forced shut.** [ECA11073]

To install the rear wheel

1. Install the wheel and the brake caliper bracket by inserting the wheel axle from the right-hand side.

TIP _____

- Make sure that the slot in the brake caliper bracket is fit over the retainer on the swingarm.
- Make sure that there is enough space between the brake pads before installing the wheel.

2. Install the drive chain onto the rear sprocket.
3. Install the axle nut.
4. Adjust the drive chain slack. (See page 7-23.)

5. Take the motorcycle off the centerstand so that the rear wheel is on the ground, and then put the sidestand down.
6. Tighten the axle nut, the brake caliper bracket bolt, and then tighten the locknuts to the specified torques.

Tightening torques:

Axle nut:

90 Nm (9.0 m·kgf, 65 ft·lbf)

Brake caliper bracket bolt:

39 Nm (3.9 m·kgf, 28 ft·lbf)

Locknut:

7 Nm (0.7 m·kgf, 5.1 ft·lbf)

PERIODIC MAINTENANCE AND ADJUSTMENT

EAU25872

Troubleshooting

Although Yamaha motorcycles receive a thorough inspection before shipment from the factory, trouble may occur during operation. Any problem in the fuel, compression, or ignition systems, for example, can cause poor starting and loss of power.

The following troubleshooting charts represent quick and easy procedures for checking these vital systems yourself. However, should your motorcycle require any repair, take it to a Yamaha dealer, whose skilled technicians have the necessary tools, experience, and know-how to service the motorcycle properly.

Use only genuine Yamaha replacement parts. Imitation parts may look like Yamaha parts, but they are often inferior, have a shorter service life and can lead to expensive repair bills.

EWA15142

WARNING

When checking the fuel system, do not smoke, and make sure there are no open flames or sparks in the area, including pilot lights from water

heaters or furnaces. Gasoline or gasoline vapors can ignite or explode, causing severe injury or property damage.

Troubleshooting charts

Starting problems or poor engine performance

1. Fuel

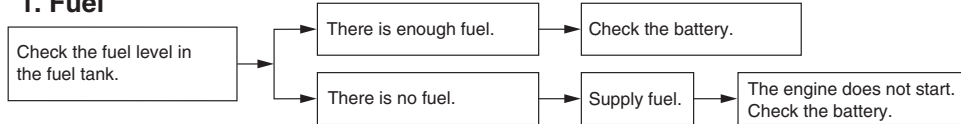

2. Battery

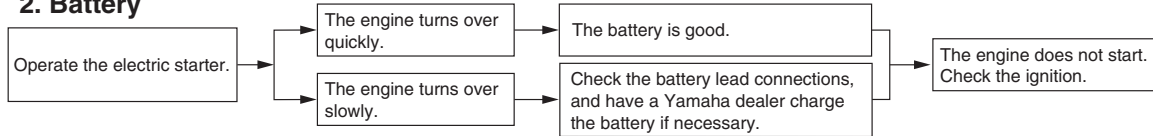

3. Ignition

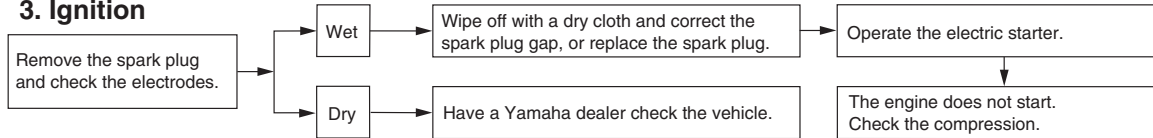

4. Compression

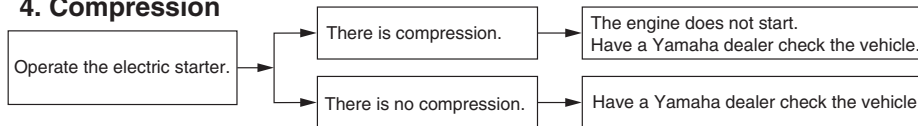

PERIODIC MAINTENANCE AND ADJUSTMENT

Engine overheating

EWA10401

⚠ WARNING

- Do not remove the radiator cap when the engine and radiator are hot. Scalding hot fluid and steam may be blown out under pressure, which could cause serious injury. Be sure to wait until the engine has cooled.
- After removing the radiator cap retaining bolt, place a thick rag, like a towel, over the radiator cap, and then slowly rotate the cap counterclockwise to the detent to allow any residual pressure to escape. When the hissing sound has stopped, press down on the cap while turning it counterclockwise, and then remove the cap.

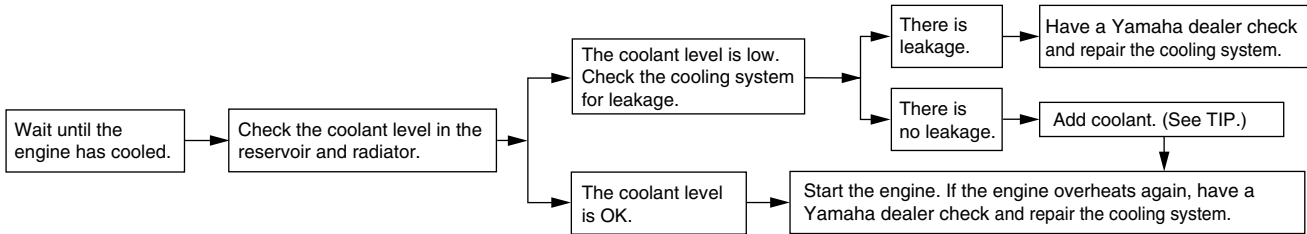

TIP

If coolant is not available, tap water can be temporarily used instead, provided that it is changed to the recommended coolant as soon as possible.

Matte color caution

EAU37834

NOTICE

Some models are equipped with matte colored finished parts. Be sure to consult a Yamaha dealer for advice on what products to use before cleaning the vehicle. Using a brush, harsh chemical products or cleaning compounds when cleaning these parts will scratch or damage their surface. Wax also should not be applied to any matte colored finished parts.

ECA15193

Care

EAUW0065

While the open design of a motorcycle reveals the attractiveness of the technology, it also makes it more vulnerable. Rust and corrosion can develop even if high-quality components are used. A rusty exhaust pipe may go unnoticed on a car, however, it detracts from the overall appearance of a motorcycle. Frequent and proper care does not only comply with the terms of the warranty, but it will also keep your motorcycle looking good, extend its life and optimize its performance.

Before cleaning

1. Cover the muffler outlet with a plastic bag after the engine has cooled down.
2. Make sure that all caps and covers as well as all electrical couplers and connectors, including the spark plug cap, are tightly installed.
3. Remove extremely stubborn dirt, like oil burnt onto the crankcase, with a degreasing agent and a brush, but never apply such prod-

ucts onto seals, gaskets, sprockets, the drive chain and wheel axles. Always rinse the dirt and degreaser off with water.

Cleaning

ECA10773

NOTICE

- **Avoid using strong acidic wheel cleaners, especially on spoked wheels. If such products are used on hard-to-remove dirt, do not leave the cleaner on the affected area any longer than instructed. Also, thoroughly rinse the area off with water, immediately dry it, and then apply a corrosion protection spray.**
- **Improper cleaning can damage plastic parts (such as cowlings, panels, windshields, headlight lenses, meter lenses, etc.) and the mufflers. Use only a soft, clean cloth or sponge with water to clean plastic. However, if the plastic parts cannot be thoroughly cleaned with water, diluted mild detergent with water may be used. Be sure to rinse**

MOTORCYCLE CARE AND STORAGE

off any detergent residue using plenty of water, as it is harmful to plastic parts.

- Do not use any harsh chemical products on plastic parts. Be sure to avoid using cloths or sponges which have been in contact with strong or abrasive cleaning products, solvent or thinner, fuel (gasoline), rust removers or inhibitors, brake fluid, antifreeze or electrolyte.
- Do not use high-pressure washers or steam-jet cleaners since they cause water seepage and deterioration in the following areas: seals (of wheel and swing-arm bearings, fork and brakes), electric components (couplers, connectors, instruments, switches and lights), breather hoses and vents.
- For motorcycles equipped with a windshield: Do not use strong cleaners or hard sponges as they will cause dulling or scratching. Some cleaning compounds for plastic may leave scratches on the wind-

shield. Test the product on a small hidden part of the windshield to make sure that it does not leave any marks. If the windshield is scratched, use a quality plastic polishing compound after washing.

After normal use

Remove dirt with warm water, a mild detergent, and a soft, clean sponge, and then rinse thoroughly with clean water. Use a toothbrush or bottlebrush for hard-to-reach areas. Stubborn dirt and insects will come off more easily if the area is covered with a wet cloth for a few minutes before cleaning.

After riding in the rain or near the sea

Since sea salt is extremely corrosive carry out the following steps after each ride in the rain or near the sea.

1. Clean the motorcycle with cold water and a mild detergent, after the engine has cooled down.
NOTICE: Do not use warm water since it increases the corrosive action of the salt. [ECA10792]

2. Apply a corrosion protection spray on all metal, including chrome- and nickel-plated, surfaces to prevent corrosion.

After cleaning

1. Dry the motorcycle with a chamois or an absorbing cloth.
2. Immediately dry the drive chain and lubricate it to prevent it from rusting.
3. Use a chrome polish to shine chrome, aluminum and stainless-steel parts, including the exhaust system. (Even the thermally induced discoloring of stainless-steel exhaust systems can be removed through polishing.)
4. To prevent corrosion, it is recommended to apply a corrosion protection spray on all metal, including chrome- and nickel-plated, surfaces.
5. Use spray oil as a universal cleaner to remove any remaining dirt.
6. Touch up minor paint damage caused by stones, etc.
7. Wax all painted surfaces.

8. Let the motorcycle dry completely before storing or covering it.

EWA11132

WARNING

Contaminants on the brakes or tires can cause loss of control.

- **Make sure that there is no oil or wax on the brakes or tires.**
- **If necessary, clean the brake discs and brake linings with a regular brake disc cleaner or acetone, and wash the tires with warm water and a mild detergent. Before riding at higher speeds, test the motorcycle's braking performance and cornering behavior.**

ECA10801

NOTICE

- **Apply spray oil and wax sparingly and make sure to wipe off any excess.**
- **Never apply oil or wax to any rubber and plastic parts, but treat them with a suitable care product.**

- **Avoid using abrasive polishing compounds as they will wear away the paint.**

TIP

- Consult a Yamaha dealer for advice on what products to use.
- Washing, rainy weather or humid climates can cause the headlight lens to fog. Turning the headlight on for a short period of time will help remove the moisture from the lens.

Storage

Short-term

Always store your motorcycle in a cool, dry place and, if necessary, protect it against dust with a porous cover. Be sure the engine and the exhaust system are cool before covering the motorcycle.

ECA10811

NOTICE

- **Storing the motorcycle in a poorly ventilated room or covering it with a tarp, while it is still wet, will allow water and humidity to seep in and cause rust.**
- **To prevent corrosion, avoid damp cellars, stables (because of the presence of ammonia) and areas where strong chemicals are stored.**

Long-term

Before storing your motorcycle for several months:

1. Follow all the instructions in the "Care" section of this chapter.

MOTORCYCLE CARE AND STORAGE

2. Fill up the fuel tank and add fuel stabilizer (if available) to prevent the fuel tank from rusting and the fuel from deteriorating.
3. Perform the following steps to protect the cylinder, piston rings, etc. from corrosion.
 - a. Remove the spark plug cap and spark plug.
 - b. Pour a teaspoonful of engine oil into the spark plug bore.
 - c. Install the spark plug cap onto the spark plug, and then place the spark plug on the cylinder head so that the electrodes are grounded. (This will limit sparking during the next step.)
 - d. Turn the engine over several times with the starter. (This will coat the cylinder wall with oil.)
WARNING! To prevent damage or injury from sparking, make sure to ground the spark plug electrodes while turning the engine over.
 - e. Remove the spark plug cap from the spark plug, and then install the spark plug and the spark plug cap.
4. Lubricate all control cables and the pivoting points of all levers and pedals as well as of the side-stand/centerstand.
5. Check and, if necessary, correct the tire air pressure, and then lift the motorcycle so that both of its wheels are off the ground. Alternatively, turn the wheels a little every month in order to prevent the tires from becoming degraded in one spot.
6. Cover the muffler outlet with a plastic bag to prevent moisture from entering it.
7. Remove the battery and fully charge it. Store it in a cool, dry place and charge it once a month. Do not store the battery in an excessively cold or warm place [less than 0 °C (30 °F) or more than 30 °C (90 °F)]. For more information on storing the battery, see page 7-29.

[EWA10952]

TIP

Make any necessary repairs before storing the motorcycle.

Dimensions:

- Overall length:
1970 mm (77.6 in)
- Overall width:
670 mm (26.4 in)
- Overall height:
1080 mm (42.5 in)
- Seat height:
780 mm (30.7 in)
- Wheelbase:
1290 mm (50.8 in)
- Ground clearance:
135 mm (5.31 in)
- Minimum turning radius:
1990 mm (78.3 in)

Weight:

- Curb weight:
116 kg (256 lb)

Engine:

- Engine type:
Liquid cooled 4-stroke, SOHC
- Cylinder arrangement:
Single cylinder
- Displacement:
149 cm³
- Bore × stroke:
57.0 × 58.7 mm (2.24 × 2.31 in)
- Compression ratio:
10.4 : 1
- Starting system:
Electric starter and kickstarter
- Lubrication system:
Wet sump

Engine oil:

- Recommended brand:
YAMALUBE
- Type:
SAE 10W-40 or 20W-40

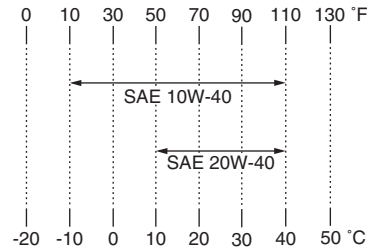

Engine oil quantity:

- Without oil filter element replacement:
0.95 L (1.00 US qt, 0.84 Imp.qt)
- With oil filter element replacement:
1.00 L (1.06 US qt, 0.88 Imp.qt)

Coolant quantity:

- Coolant reservoir (up to the maximum level mark):
0.28 L (0.30 US qt, 0.25 Imp.qt)
- Radiator (including all routes):
0.48 L (0.51 US qt, 0.42 Imp.qt)

Air filter:

- Air filter element:
Dry element

Fuel:

- Recommended fuel:
Regular unleaded gasoline (Gasohol (E10) acceptable)
- Fuel tank capacity:
4.2 L (1.11 US gal, 0.92 Imp.gal)

Spark plug(s):

- Manufacturer/model:
NGK/CR8E
- Spark plug gap:
0.7–0.8 mm (0.031–0.031 in)

Clutch:

- Clutch type:
Wet, multiple-disc

Transmission:

- Primary reduction ratio:
3.042 (73/24)
- Final drive:
Chain
- Secondary reduction ratio:
3.000 (42/14)
- Transmission type:
Constant mesh 5-speed
- Operation:
Left foot operation
- Gear ratio:
1st:
2.833 (34/12)
2nd:
1.875 (30/16)
3rd:
1.429 (30/21)
4th:
1.143 (24/21)

SPECIFICATIONS

5th:
0.957 (22/23)

Chassis:

Frame type:
Backbone
Caster angle:
26.00 °
Trail:
81 mm (3.2 in)

Front tire:

Type:
Tubeless
Size:
70/90-17M/C 38P
Manufacturer/model:
IRC/NF67

Rear tire:

Type:
Tubeless
Size:
120/70-17M/C 58P
Manufacturer/model:
IRC/NF67

Loading:

Maximum load:
151 kg (333 lb)
(Total weight of rider, passenger, cargo
and accessories)

Tire air pressure (measured on cold tires):

Front (1 person):
200 kPa (2.00 kgf/cm², 29 psi)
Rear (1 person):
225 kPa (2.25 kgf/cm², 33 psi)

Front (2 persons):
200 kPa (2.00 kgf/cm², 29 psi)

Rear (2 persons):
225 kPa (2.25 kgf/cm², 33 psi)

Front wheel:

Wheel type:
Cast wheel
Rim size:
17M/C x MT1.85

Rear wheel:

Wheel type:
Cast wheel
Rim size:
17M/C x MT3.50

Front brake:

Type:
Single disc brake
Operation:
Right hand operation
Specified brake fluid:
DOT 3 or 4

Rear brake:

Type:
Single disc brake
Operation:
Right foot operation
Specified brake fluid:
DOT 3 or 4

Front suspension:

Type:
Telescopic fork
Spring/shock absorber type:
Coil spring/oil damper

Wheel travel:
100 mm (3.9 in)

Rear suspension:

Type:
Swingarm
Spring/shock absorber type:
Coil spring/oil damper
Wheel travel:
91 mm (3.6 in)

Electrical system:

Ignition system:
TCI
Charging system:
AC magneto

Battery:

Model:
GTZ4V
Voltage, capacity:
12 V, 3.0 Ah

Headlight:

Bulb type:
Halogen bulb

Bulb voltage, wattage × quantity:

Headlight:
12 V, 35.0 W/35.0 W × 1
Tail/brake light:
LED
Front turn signal light:
12 V, 10.0 W × 2
Rear turn signal light:
12 V, 10.0 W × 2
Auxiliary light:
LED

Meter lighting:

LED

Neutral indicator light:

LED

High beam indicator light:

LED

Turn signal indicator light:

LED

Coolant temperature warning light:

LED

Engine trouble warning light:

LED

Fuses:

Main fuse:

15.0 A

Sub fuse:

7.5 A

CONSUMER INFORMATION

EAU26364

Identification numbers

Record the vehicle identification number and the engine serial number in the spaces provided below for assistance when ordering spare parts from a Yamaha dealer or for reference in case the vehicle is stolen.

VEHICLE IDENTIFICATION NUMBER:

ENGINE SERIAL NUMBER:

Vehicle identification number

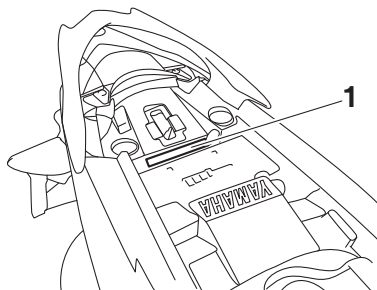

1. Vehicle identification number

The vehicle identification number is stamped into the frame under the seat. (See page 4-12.)

TIP

The vehicle identification number is used to identify your vehicle and may be used to register it with the licensing authority in your area.

EAU0540

Engine serial number

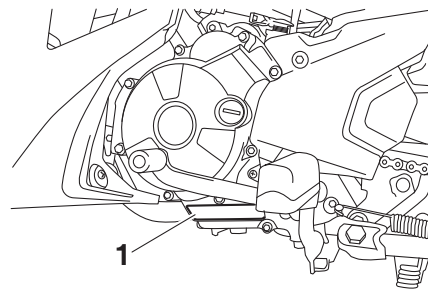

1. Engine serial number

The engine serial number is stamped on the bottom left side of the crankcase.

EAUU1221

- A**
 Air filter element, cleaning 7-14
 Auxiliary light 7-32
- B**
 Battery 7-29
 Brake and clutch levers,
 checking and lubricating 7-26
 Brake fluid, changing 7-23
 Brake fluid level, checking 7-22
 Brake lever 4-8
 Brake lever free play, checking 7-20
 Brake light switches 7-21
 Brake pedal 4-9
 Brake pedal, checking and
 lubricating 7-26
- C**
 Cables, checking and lubricating 7-25
 Care 8-1
 Catalytic converter 4-11
 Centerstand and sidestand,
 checking and lubricating 7-27
 Clutch lever 4-8
 Clutch lever free play, adjusting 7-19
 Coolant 7-12
 Coolant temperature warning light 4-3
 Cowling and panels, removing
 and installing 7-7
- D**
 Dimmer switch 4-7
 Drive chain, cleaning and lubricating ... 7-25
 Drive chain slack 7-23
- E**
 Engine break-in 6-3
 Engine idling speed 7-15
- Engine oil and oil filter element 7-10
 Engine serial number 10-1
 Engine trouble warning light 4-3
- F**
 Front and rear brake pads,
 checking 7-21
 Front fork, checking 7-28
 Fuel 4-10
 Fuel consumption, tips for reducing 6-3
 Fuel tank cap 4-9
 Fuses, replacing 7-30
- G**
 General note 6-5
- H**
 Handlebar switches 4-7
 Headlight bulb, replacing 7-31
 Helmet holders 4-13
 Helmets 2-6
 High beam indicator light 4-3
 Horn switch 4-7
- I**
 Identification numbers 10-1
 Indicator lights and warning lights 4-3
- K**
 Keyhole cover 4-2
 Kickstarter 4-12
- L**
 Labels, location 1-1
 License plate light bulb, replacing 7-34
- M**
 Main switch/steering lock 4-1
 Maintenance and lubrication,
 periodic 7-3
- Maintenance, emission control
 system 7-2
 Matte color, caution 8-1
 Multi-function meter unit 4-4
- N**
 Neutral indicator light 4-3
- P**
 Parking 6-4
 Part locations 3-1
- R**
 Rear turn signal light bulb, replacing 7-33
- S**
 Safe-riding points 2-5
 Safety information 2-1
 Seat 4-12
 Shifting 6-2
 Shift pedal 4-8
 Shift pedal, checking 7-20
 Sidestand 4-14
 Spark plug, checking 7-8
 Specifications 9-1
 Starting circuit cut-off system 4-14
 Starting the engine 6-2
 Start switch 4-7
 Steering, checking 7-28
 Storage 8-3
 Storage compartment 4-13
 Swingarm pivots, lubricating 7-27
- T**
 Tail/brake light 7-32
 Throttle grip and cable,
 checking and lubricating 7-25
 Throttle grip free play, adjusting 7-16
 Tires 7-17

INDEX

Tool kit	7-1
Troubleshooting	7-37
Troubleshooting charts	7-38
Turn signal indicator light	4-3
Turn signal light bulb (front), replacing	7-33
Turn signal switch	4-7

V

Valve clearance	7-16
Vehicle identification number	10-1

W

Wheel bearings, checking	7-29
Wheel (front)	7-35
Wheel (rear)	7-35
Wheels	7-18



PRINTED IN VIETNAM
2017.07 (E)