



⚠ Read this manual carefully before operating this vehicle.

OWNER'S MANUAL

fazzio

LCF125-C/LCF125-F

BKF-F8199-E3



เครื่องวิทยุคมนาคมและอุปกรณ์นี้ มีความสอดคล้องตาม
 มาตรฐานหรือข้อกำหนดทางเทคนิคของ กสทช.

 **Read this manual carefully before operating this vehicle. This manual should stay with this vehicle if it is sold.**

Welcome to the Yamaha world of motorcycling!

As the owner of the LCF125-C/LCF125-F, you are benefiting from Yamaha's vast experience and newest technology regarding the design and manufacture of high-quality products, which have earned Yamaha a reputation for dependability. Please take the time to read this manual thoroughly, so as to enjoy all advantages of your LCF125-C/LCF125-F. The Owner's Manual does not only instruct you in how to operate, inspect and maintain your motorcycle, but also in how to safeguard yourself and others from trouble and injury.

In addition, the many tips given in this manual will help keep your motorcycle in the best possible condition. If you have any further questions, do not hesitate to contact your Yamaha dealer.

The Yamaha team wishes you many safe and pleasant rides. So, remember to put safety first!

Yamaha continually seeks advancements in product design and quality. Therefore, while this manual contains the most current product information available at the time of printing, there may be minor discrepancies between your motorcycle and this manual. If there is any question concerning this manual, please consult a Yamaha dealer.



 **WARNING**

Please read this manual carefully and completely before operating this motorcycle.

Important manual information

EAU10134

Particularly important information is distinguished in this manual by the following notations:

| | |
|--|---|
|  | This is the safety alert symbol. It is used to alert you to potential personal injury hazards. Obey all safety messages that follow this symbol to avoid possible injury or death. |
|  | A WARNING indicates a hazardous situation which, if not avoided, could result in death or serious injury. |
|  | A NOTICE indicates special precautions that must be taken to avoid damage to the vehicle or other property. |
| TIP | A TIP provides key information to make procedures easier or clearer. |

*Product and specifications are subject to change without notice.

EAU37432

**LCF125-C/LCF125-F
OWNER'S MANUAL**
©2026 by Thai Yamaha Motor Co., Ltd.
1st edition, January 2026
All rights reserved.
Any reprinting or unauthorized use
without the written permission of
Thai Yamaha Motor Co., Ltd.
is expressly prohibited.
Printed in Thailand.

Table of contents

| | | | | | |
|---|-----|---|------|--|-------|
| Location of important labels | 1-1 | Multi-function meter unit..... | 7-7 | Periodic maintenance and adjustment | 10-1 |
| Safety information | 2-1 | Handlebar switches | 7-10 | Tool kit..... | 10-1 |
| Further safe-riding points | 2-5 | Front brake lever..... | 7-11 | Periodic maintenance chart for the emission control system | 10-2 |
| Helmets | 2-6 | Rear brake lever | 7-12 | General maintenance and lubrication chart | 10-3 |
| Description | 3-1 | Fuel tank cap | 7-12 | Removing and installing panels.... | 10-8 |
| Left view | 3-1 | Fuel | 7-13 | Checking the spark plug..... | 10-9 |
| Right view | 3-2 | Catalytic converter | 7-14 | Engine oil and oil strainer | 10-10 |
| Controls and instruments | 3-3 | Kickstarter (LCF125-C) | 7-15 | Why Yamalube..... | 10-12 |
| Smart key system (LCF125-F) | 4-1 | Seat..... | 7-15 | Final transmission oil | 10-13 |
| Smart key system..... | 4-1 | Helmet holders..... | 7-16 | Air filter and V-belt case air filter elements..... | 10-14 |
| Smartphone Connectivity System | 5-1 | Storage compartments | 7-17 | Checking the throttle grip free play..... | 10-16 |
| CCU (Communication Control Unit)..... | 5-1 | Luggage hook | 7-18 | Valve clearance..... | 10-17 |
| Stop and Start System | 6-1 | USB Type-A jack..... | 7-18 | Tires | 10-17 |
| Stop and Start System | 6-1 | Sidestand | 7-19 | Cast wheels | 10-19 |
| Stop and Start System operation..... | 6-1 | Ignition circuit cut-off system | 7-20 | Checking the front brake lever free play..... | 10-19 |
| Instrument and control functions | 7-1 | For your safety – pre-operation checks | 8-1 | Adjusting the rear brake lever free play..... | 10-20 |
| Main switch (LCF125-F) | 7-1 | Operation and important riding points | 9-1 | Checking the front brake pads and rear brake shoes | 10-20 |
| Main switch/steering lock..... | 7-4 | Engine break-in | 9-1 | Checking the brake fluid level ... | 10-21 |
| Keyhole shutter | 7-5 | Starting the engine..... | 9-2 | Changing the brake fluid | 10-22 |
| Indicator lights and warning lights..... | 7-5 | Starting off | 9-3 | Checking the V-belt..... | 10-22 |
| | | Acceleration and deceleration | 9-3 | Checking and lubricating the cables..... | 10-23 |
| | | Braking..... | 9-4 | | |
| | | Tips for reducing fuel consumption..... | 9-4 | | |
| | | Parking | 9-4 | | |

Table of contents

- Checking and lubricating the throttle grip and cable.....10-23
- Lubricating the front and rear brake levers10-23
- Checking and lubricating the centerstand and sidestand10-24
- Checking the front fork.....10-25
- Checking the steering10-25
- Checking the wheel bearings10-26
- Battery10-26
- Replacing the fuses.....10-28
- Headlight10-29
- Auxiliary light10-29
- Front/rear turn signal light and tail/brake light10-29
- Troubleshooting10-30
- Troubleshooting chart10-32
- Emergency mode (LCF125-F)10-33

- Motorcycle care and storage11-1**
 - Matte color caution11-1
 - Care.....11-1
 - Storage.....11-3

- Specifications.....12-1**

- Consumer information13-1**
 - Identification numbers.....13-1
 - Vehicle data recording13-2

- Index14-1**

Location of important labels

EAU10387

1

Read and understand all of the labels on your vehicle. They contain important information for safe and proper operation of your vehicle. Never remove any labels from your vehicle. If a label becomes difficult to read or comes off, a replacement label is available from your Yamaha dealer.

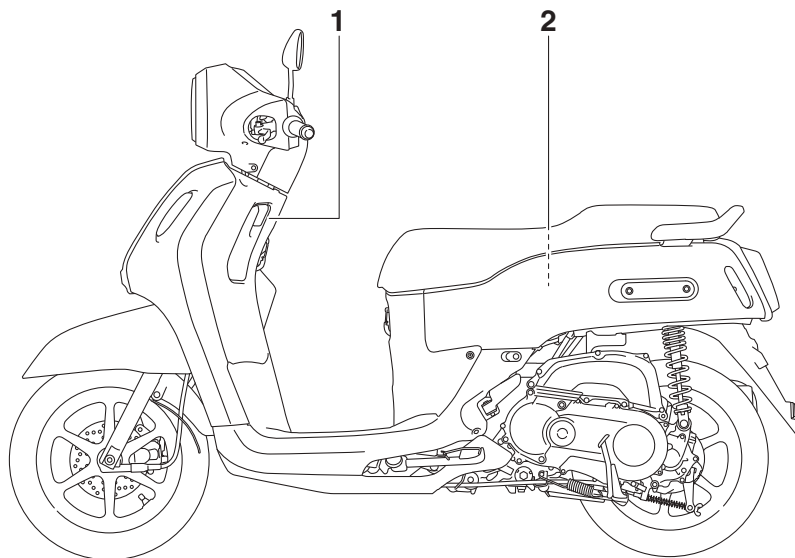

1

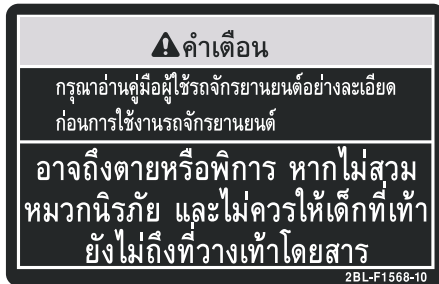

2

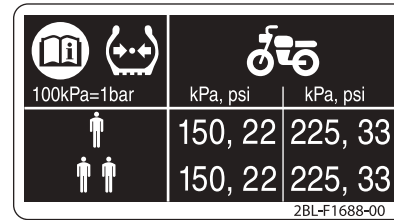

EAU1028D

2

Be a Responsible Owner

As the vehicle's owner, you are responsible for the safe and proper operation of your motorcycle.

Motorcycles are single-track vehicles. Their safe use and operation are dependent upon the use of proper riding techniques as well as the expertise of the operator. Every operator should know the following requirements before riding this motorcycle.

He or she should:

- Obtain thorough instructions from a competent source on all aspects of motorcycle operation.
- Observe the warnings and maintenance requirements in this Owner's Manual.
- Obtain qualified training in safe and proper riding techniques.
- Obtain professional technical service as indicated in this Owner's Manual and/or when made necessary by mechanical conditions.

- Never operate a motorcycle without proper training or instruction. Take a training course. Beginners should receive training from a certified instructor. Contact an authorized motorcycle dealer to find out about the training courses nearest you.

Safe Riding

Perform the pre-operation checks each time you use the vehicle to make sure it is in safe operating condition. Failure to inspect or maintain the vehicle properly increases the possibility of an accident or equipment damage. See page 8-1 for a list of pre-operation checks.

- This motorcycle is designed to carry the operator and a passenger.
- The failure of motorists to detect and recognize motorcycles in traffic is the predominating cause of automobile/motorcycle accidents. Many accidents have been caused by an automobile driver who did not see the motorcycle. Making yourself conspicuous ap-

pears to be very effective in reducing the chance of this type of accident.

Therefore:

- Wear a brightly colored jacket.
- Use extra caution when you are approaching and passing through intersections, since intersections are the most likely places for motorcycle accidents to occur.
- Ride where other motorists can see you. Avoid riding in another motorist's blind spot.
- Never maintain a motorcycle without proper knowledge. Contact an authorized motorcycle dealer to inform you on basic motorcycle maintenance. Certain maintenance can only be carried out by certified staff.

- Many accidents involve inexperienced operators. In fact, many operators who have been involved in accidents do not even have a current motorcycle license.
 - Make sure that you are qualified and that you only lend your motorcycle to other qualified operators.
 - Know your skills and limits. Staying within your limits may help you to avoid an accident.
 - We recommend that you practice riding your motorcycle where there is no traffic until you have become thoroughly familiar with the motorcycle and all of its controls.
- Many accidents have been caused by error of the motorcycle operator. A typical error made by the operator is veering wide on a turn due to excessive speed or undercornering (insufficient lean angle for the speed).
 - Always obey the speed limit and never travel faster than warranted by road and traffic conditions.
- Always signal before turning or changing lanes. Make sure that other motorists can see you.
- The posture of the operator and passenger is important for proper control.
 - The operator should keep both hands on the handlebar and both feet on the operator footrests during operation to maintain control of the motorcycle.
 - The passenger should always hold onto the operator, the seat strap or grab bar, if equipped, with both hands and keep both feet on the passenger footrests. Never carry a passenger unless he or she can firmly place both feet on the passenger footrests.
- Never ride under the influence of alcohol or other drugs.
- This motorcycle is designed for on-road use only. It is not suitable for off-road use.

Protective Apparel

The majority of fatalities from motorcycle accidents are the result of head injuries. The use of a safety helmet is the single most critical factor in the prevention or reduction of head injuries.

- Always wear an approved helmet.
- Wear a face shield or goggles. Wind in your unprotected eyes could contribute to an impairment of vision that could delay seeing a hazard.
- The use of a jacket, heavy boots, trousers, gloves, etc., is effective in preventing or reducing abrasions or lacerations.
- Never wear loose-fitting clothes, otherwise they could catch on the control levers, footrests, or wheels and cause injury or an accident.
- Always wear protective clothing that covers your legs, ankles, and feet. The engine or exhaust system become very hot during or after operation and can cause burns.
- A passenger should also observe the above precautions.

Safety information

2

Avoid Carbon Monoxide Poisoning

All engine exhaust contains carbon monoxide, a deadly gas. Breathing carbon monoxide can cause headaches, dizziness, drowsiness, nausea, confusion, and eventually death.

Carbon Monoxide is a colorless, odorless, tasteless gas which may be present even if you do not see or smell any engine exhaust. Deadly levels of carbon monoxide can collect rapidly and you can quickly be overcome and unable to save yourself. Also, deadly levels of carbon monoxide can linger for hours or days in enclosed or poorly ventilated areas. If you experience any symptoms of carbon monoxide poisoning, leave the area immediately, get fresh air, and **SEEK MEDICAL TREATMENT.**

- Do not run engine indoors. Even if you try to ventilate engine exhaust with fans or open windows and doors, carbon monoxide can rapidly reach dangerous levels.
- Do not run engine in poorly ventilated or partially enclosed areas such as barns, garages, or carports.

- Do not run engine outdoors where engine exhaust can be drawn into a building through openings such as windows and doors.

Loading

Adding accessories or cargo to your motorcycle can adversely affect stability and handling if the weight distribution of the motorcycle is changed. To avoid the possibility of an accident, use extreme caution when adding cargo or accessories to your motorcycle. Use extra care when riding a motorcycle that has added cargo or accessories. Here, along with the information about accessories below, are some general guidelines to follow if loading cargo to your motorcycle:

The total weight of the operator, passenger, accessories and cargo must not exceed the maximum load limit.

Operation of an overloaded vehicle could cause an accident.

| |
|---|
| <p>Maximum load: 158 kg (348 lb)</p> |
|---|

When loading within this weight limit, keep the following in mind:

- Cargo and accessory weight should be kept as low and close to the motorcycle as possible. Securely pack your heaviest items as close to the center of the vehicle as possible and make sure to distribute the weight as evenly as possible on both sides of the motorcycle to minimize imbalance or instability.
- Shifting weights can create a sudden imbalance. Make sure that accessories and cargo are securely attached to the motorcycle before riding. Check accessory mounts and cargo restraints frequently.
- Properly adjust the suspension for your load (suspension-adjustable models only), and check the condition and pressure of your tires.
- Never attach any large or heavy items to the handlebar, front fork, or front fender. These items, including such cargo as sleeping bags, duffel bags, or

tents, can create unstable handling or a slow steering response.

- **This vehicle is not designed to pull a trailer or to be attached to a sidecar.**

Genuine Yamaha Accessories

Choosing accessories for your vehicle is an important decision. Genuine Yamaha accessories, which are available only from a Yamaha dealer, have been designed, tested, and approved by Yamaha for use on your vehicle.

Many companies with no connection to Yamaha manufacture parts and accessories or offer other modifications for Yamaha vehicles. Yamaha is not in a position to test the products that these aftermarket companies produce. Therefore, Yamaha can neither endorse nor recommend the use of accessories not sold by Yamaha or modifications not specifically recommended by Yamaha, even if sold and installed by a Yamaha dealer.

Aftermarket Parts, Accessories, and Modifications

While you may find aftermarket products similar in design and quality to genuine Yamaha accessories, recognize that some aftermarket accessories or modifications are not suitable because of potential safety hazards to you or others. Installing aftermarket products or having other modifications performed to your vehicle that change any of the vehicle's design or operation characteristics can put you and others at greater risk of serious injury or death. You are responsible for injuries related to changes in the vehicle.

Keep the following guidelines in mind, as well as those provided under "Loading" when mounting accessories.

- Never install accessories or carry cargo that would impair the performance of your motorcycle. Carefully inspect the accessory before using it to make sure that it does not in any way reduce ground clearance or cornering clearance, limit suspension travel,

steering travel or control operation, or obscure lights or reflectors.

- Accessories fitted to the handlebar or the front fork area can create instability due to improper weight distribution or aerodynamic changes. If accessories are added to the handlebar or front fork area, they must be as lightweight as possible and should be kept to a minimum.
- Bulky or large accessories may seriously affect the stability of the motorcycle due to aerodynamic effects. Wind may attempt to lift the motorcycle, or the motorcycle may become unstable in cross winds. These accessories may also cause instability when passing or being passed by large vehicles.
- Certain accessories can displace the operator from his or her normal riding position. This improper position limits the freedom of movement of the

Safety information

2

operator and may limit control ability, therefore, such accessories are not recommended.

- Use caution when adding electrical accessories. If electrical accessories exceed the capacity of the motorcycle's electrical system, an electric failure could result, which could cause a dangerous loss of lights or engine power.

Aftermarket Tires and Rims

The tires and rims that came with your motorcycle were designed to match the performance capabilities and to provide the best combination of handling, braking, and comfort. Other tires, rims, sizes, and combinations may not be appropriate. See page 10-17 for tire specifications and for information on servicing and replacing your tires.

Transporting the Motorcycle

Be sure to observe following instructions before transporting the motorcycle in another vehicle.

- Remove all loose items from the motorcycle.
- Check that the fuel cock (if equipped) is in the off position and that there are no fuel leaks.
- Shift the transmission into gear (for models with a manual transmission).
- Secure the motorcycle with tie-downs or suitable straps that are attached to solid parts of the motorcycle, such as the frame or upper front fork triple clamp (and not, for example, to rubber-mounted handlebars or turn signals, or parts that could break). Choose the location for the straps carefully so the straps will not rub against painted surfaces during transport.
- The suspension should be compressed somewhat by the tie-downs, if possible, so that the motorcycle will not bounce excessively during transport.

Further safe-riding points

EAU57610

- Be sure to signal clearly when making turns.
- Braking can be extremely difficult on a wet road. Avoid hard braking, because the motorcycle could slide. Apply the brakes slowly when stopping on a wet surface.
- Slow down as you approach a corner or turn. Once you have completed a turn, accelerate slowly.
- Be careful when passing parked cars. A driver might not see you and open a door in your path.
- Railroad crossings, streetcar rails, iron plates on road construction sites, and manhole covers become extremely slippery when wet. Slow down and cross them with caution. Keep the motorcycle upright, otherwise it could slide out from under you.
- The brake pads or linings could get wet when you wash the motorcycle. After washing the motorcycle, check the brakes before riding.

- Always wear a helmet, gloves, trousers (tapered around the cuff and ankle so they do not flap), and a brightly colored jacket.
- Do not carry too much luggage on the motorcycle. An overloaded motorcycle is unstable. Use a strong cord to secure any luggage to the carrier (if equipped). A loose load will affect the stability of the motorcycle and could divert your attention from the road. (See page 2-3.)

Helmet

EAUU0033

Operating this vehicle without an approved motorcycle helmet increases your chances of a severe head injury or death in the event of an accident. The majority of fatalities from motorcycle or scooter accidents are the result of head injuries. The use of a safety helmet is the single most critical factor in the prevention or reduction of head injuries.

Always select an approved motorcycle helmet

Pay attention to the following when choosing a motorcycle helmet.

- The helmet must meet the safety standard “TIS”.
- The helmet size must match the size of the rider’s head.
- Never subject a helmet to heavy shocks.

Wearing the helmet correctly

Always connect the chin strap. In the case of an accident, the helmet has a much less chance of coming off if the chin strap is connected.

Correct usage



ZAUU0003

Wrong usage



ZAUU0007

Types of helmets and their usage

- Half-type: use only for riding at low speeds
- Full-type: use only for riding at low to mid-range speeds

Safety information

2



ZAUU0005

- Full-face-type: use for riding at mid-range to high speeds

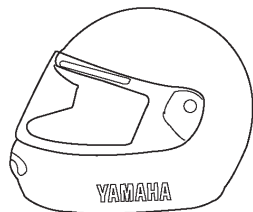

ZAUU0006

Left view

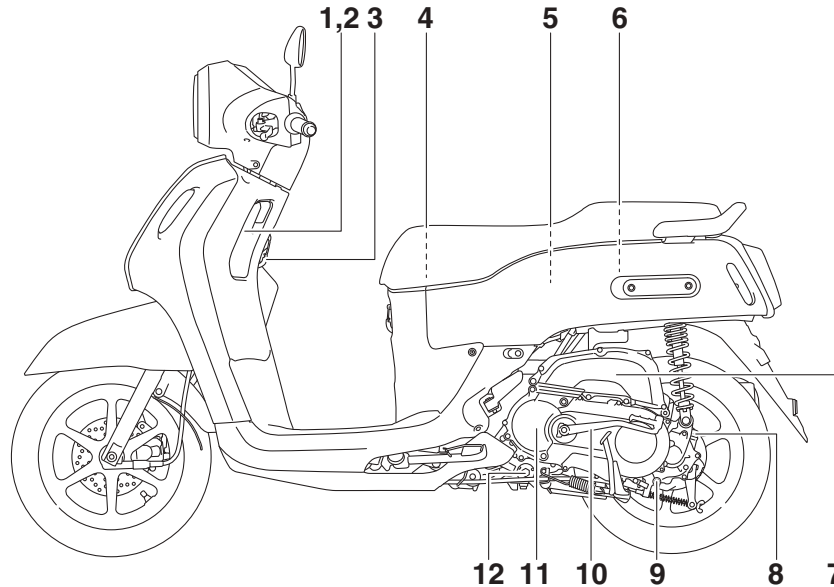

1. Front storage compartment A (page 7-17)
2. USB Type-A jack (page 7-18)
3. Hook A (page 7-18)
4. Tool kit (page 10-1)
5. Rear storage compartment (page 7-17)
6. Fuel tank cap (page 7-12)
7. Air filter element (page 10-14)
8. Final transmission oil filler cap (page 10-13)

9. Final transmission oil drain bolt (page 10-13)
10. Kickstarter (for equipped models) (page 7-15)
11. V-belt case air filter element (page 10-14)
12. Engine oil drain bolt A (page 10-10)

Description

EAU10421

Right view

3

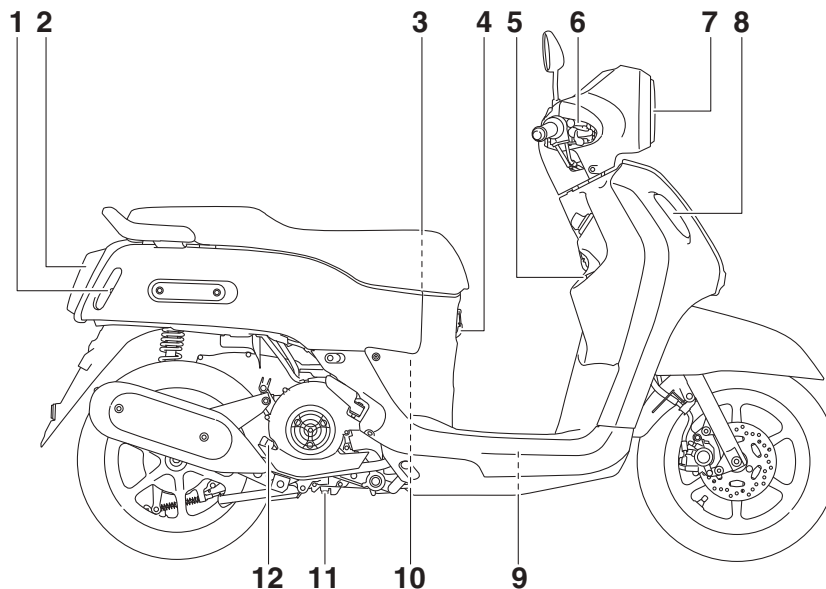

1. Rear turn signal lights (page 10-29)

2. Tail/brake light (page 10-29)

3. Fuse box (page 10-28)

4. Hook B (page 7-18)

5. Front storage compartment B (page 7-17)

6. Front brake fluid reservoir (page 10-21)

7. Headlight (page 10-29)

8. Front turn signal light (page 10-29)

9. Battery (page 10-26)

10. Spark plug (page 10-9)

11. Engine oil drain bolt B (page 10-10)

12. Engine oil filler cap (page 10-10)

Controls and instruments

LCF125-C

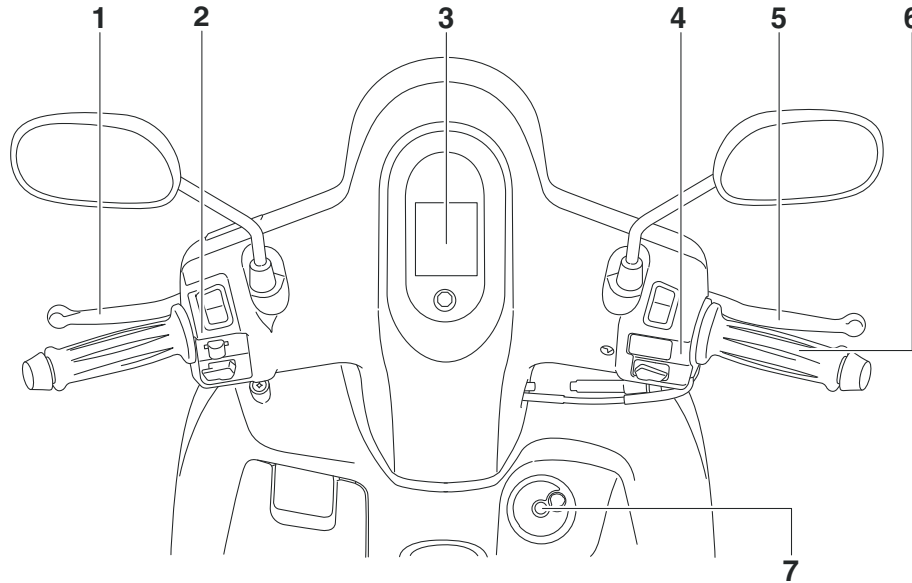

1. Rear brake lever (page 7-12)
2. Left handlebar switches (page 7-10)
3. Multi-function meter unit (page 7-7)
4. Right handlebar switches (page 7-10)
5. Front brake lever (page 7-11)
6. Throttle grip (page 10-16)
7. Main switch/steering lock (page 7-4/7-1)

Description

LCF125-F

3

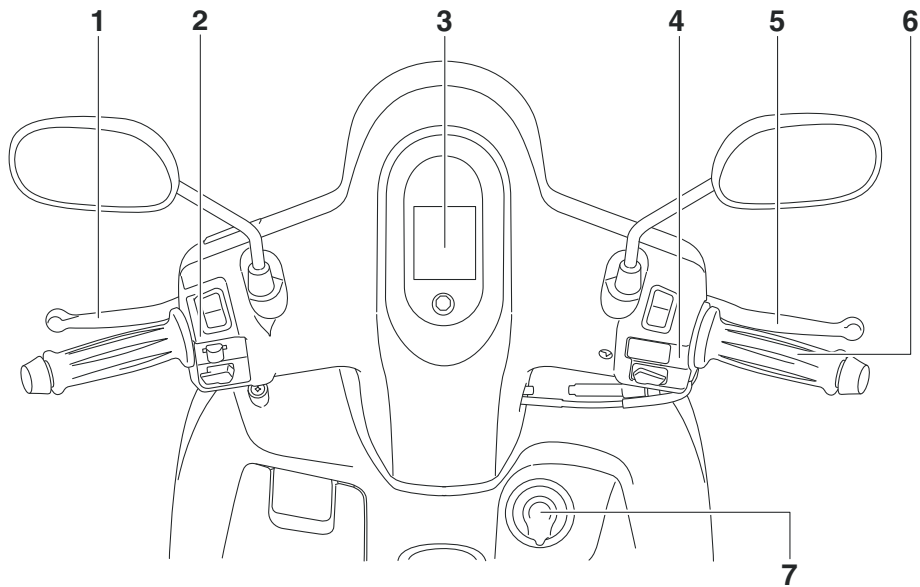

1. Rear brake lever (page 7-12)
2. Left handlebar switches (page 7-10)
3. Multi-function meter unit (page 7-7)
4. Right handlebar switches (page 7-10)
5. Front brake lever (page 7-11)
6. Throttle grip (page 10-16)
7. Main switch (page 7-4/7-1)

Smart key system

The smart key system enables you to operate the vehicle without using a mechanical key.

EAU99231

EAU8530

Included with the vehicle is one smart key, two mechanical keys, and one identification number card.

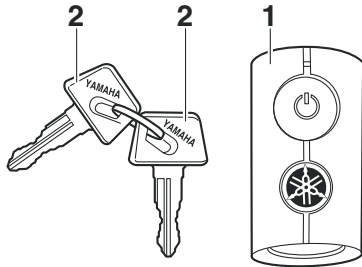

1. Smart key
2. Mechanical key

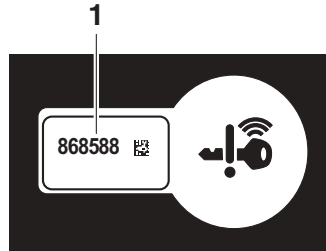

1. Identification number card

EWA22271

! WARNING

- **KEEP OUT OF REACH OF CHILDREN**
The smart key contains a coin/button cell battery.
- **Swallowing can lead to chemical burns, perforation of soft tissue, and death, Severe burns can occur within 2 hours of ingestion. Seek medical attention immediately.**

TIP

- You can register up to six smart keys for the same vehicle. See a Yamaha dealer regarding spare smart keys.
- If a smart key is lost, contact a Yamaha dealer immediately to prevent the vehicle from being stolen.

If the vehicle battery is discharged, the mechanical key can be used to open the seat. **Carry one mechanical key in addition to the smart key.**

If the smart key is lost or the smart key battery has discharged, the identification number can be used to operate the vehicle in emergency mode. (See page 10-33.) **Write down the identification number in case of emergency.**

If the smart key(s) and identification number card(s) are all lost or damaged, and there is no record of the identification number, the entire smart key system will need to be replaced.

Smart key system (LCF125-F)

4

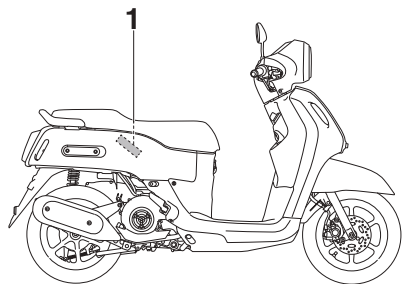

1. Vehicle mounted antenna

EWA14704

⚠ WARNING

- Keep implanted pacemakers or cardiac defibrillators, as well as other electric medical devices away from the vehicle mounted antenna (see illustration).
- Radio waves transmitted by the antenna may affect the operation of such devices when close by.
- If you have an electric medical device, consult a doctor or the device manufacturer before using this vehicle.

Operating range of the smart key system

The approximate operating range of the smart key system is shown below.

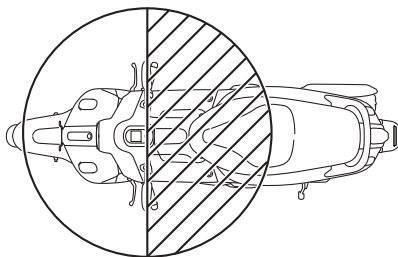
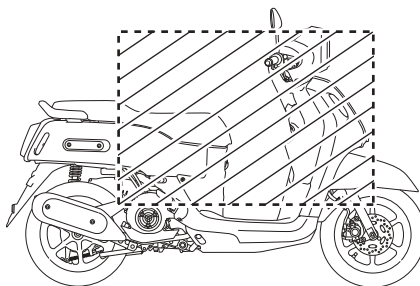

ECA29030

NOTICE

- The smart key should be carried with you. Do not store it on the vehicle.

- When the smart key is within operating range, exercise due care because other people not carrying the smart key can start the engine and operate the vehicle.

If the smart key is turned off, the vehicle will not recognize the smart key even if it is within operating range. If the smart key battery is discharged, the smart key system may not work or its operating range may become very short.

TIP

- Do not place the smart key in a storage compartment.
- Always carry the smart key with you.
- Turn the smart key off when leaving the vehicle.
- The smart key system uses weak radio waves. The smart key system may not work in the following situations:
 - The smart key is placed in a location exposed to strong radio waves or other electromagnetic noise

- There are facilities nearby that are emitting strong radio waves (TV or radio towers, power plants, broadcasting stations, airports, etc.)
 - You are carrying or using communication equipment such as radios or mobile phones in close proximity of the smart key
 - The smart key is in contact with or covered by a metallic object
 - Other vehicles equipped with a smart key system are nearby
- In such situations, move the smart key to another location and perform the operation again. If it still does not work, operate the vehicle in emergency mode. (See page 10-33.)
- To preserve vehicle battery power, the smart key system turns off approximately 9 days after the vehicle was last used. In this situation, simply push the main switch knob to turn the smart key system back on.

NOTICE

The smart key has precision electronic components. Observe the following precautions to prevent possible malfunction or damage.

- Do not place or store the smart key in a storage compartment. The smart key may be damaged from road vibrations or excessive heat.
- Do not drop, bend, or subject the smart key to strong impacts.
- Do not submerge the smart key in water or other liquids.
- Do not place heavy items or excessive stress on the smart key.
- Do not leave the smart key in a place exposed to direct sunlight, high temperature or high humidity.
- Do not grind or attempt to modify the smart key.
- Keep the smart key away from strong magnetic fields and magnetic objects such as key holders, TVs, and computers.
- Keep the smart key away from electric medical equipment.

ECA21573

- Do not allow oils, polishing agents, fuel, or any strong chemicals to come in contact with the smart key. The smart key body may become discolored or cracked.

Using the smart key

EAAU8710

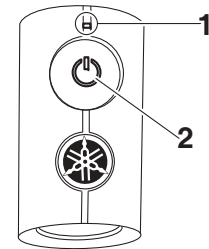

1. Smart key indicator light
2. Smart key button

When the smart key is turned on and brought within range, the smart key system allows you to operate the vehicle without inserting a mechanical key. If the smart key is turned off, the vehicle cannot be operated even if the smart key is within operating range of the vehicle.

Smart key system (LCF125-F)

The current status of the key can be checked by briefly pressing the smart key button.

- Short flash: the key is on
- Long flash: the key is off

To turn the smart key on or off

To turn the smart key on or off, press the smart key button for one second. The smart key indicator light will flash. If the key does a short flash, the key is on. If the key does a long flash, the key is off.

EAUJ8560

Remote answer-back function

The smart key system is equipped with an answer-back function to help you locate the vehicle in parking lots.

Push the smart key button to operate the answer-back function remotely. The beeper will sound twice and all of the turn signal lights will flash twice. This feature is convenient for locating your vehicle in parking lots and other areas.

Operating range of the answer-back function

The approximate operating range of the answer-back function is as shown.

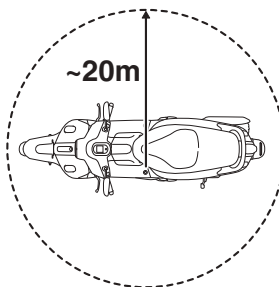

As the smart key system uses weak radio waves, the operating range may be affected by the surrounding environment.

To turn the answer-back beeper on or off

The beeper, which sounds when the answer-back function is operated, can be turned on or off according to the following procedure.

1. Turn the smart key on and bring it within operating range.

2. Turn the main switch to “OFF”, and then push the main switch knob once.
3. Within 9 seconds of pushing the knob, push and hold the knob again for 5 seconds.
4. When the beeper sounds, the setting is complete.

If the beeper:

- Sounds twice: The beeper is turned off.
- Sounds once: The beeper is turned on.

TIP

If the answer-back function does not operate when the smart key button is pressed, the smart key battery may need to be changed.

EAUJ8603

Smart key battery

Replace the smart key battery if any of the following occur:

- The smart key system indicator light (page 7-6) flashes for about 20 seconds when the vehicle power is turned on.

Smart key system (LCF125-F)

- The smart key indicator light does not flash when the smart key button is pressed.

Specified battery:
CR2032
Nominal voltage:
3 V

EWA22830

WARNING

This battery contains combustible materials such as lithium metal and organic electrolyte. The following cautions should be followed in order to use this battery safely:

- Do not short circuit the battery
- Do not charge the battery
- Do not soak the battery in water
- Do not deform or damage the battery
- Do not modify the battery in any way

TIP

- The smart key battery life is approximately two years, but this may vary according to operating conditions.

- The smart key battery may become discharged even if it is away from the vehicle and not being used.
- If the smart key continually receives radio waves, the smart key battery will discharge quickly. (For example, when placed in the vicinity of electrical products such as televisions, radios, or computers.)
- After changing the smart key battery, if the smart key system still does not operate, have a Yamaha dealer check the vehicle.

To replace the smart key battery

1. Gently pry open the smart key case as shown. Otherwise, have a Yamaha dealer replace the battery.

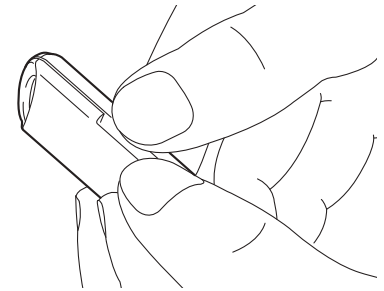

2. Remove the battery.

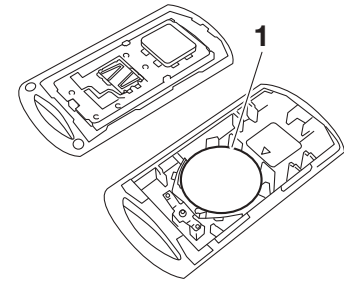

1. Battery

TIP

Dispose of the removed battery in accordance with local regulations.

3. Note the polarity of the battery and install it with the positive “+” side facing downwards as shown.

Smart key system (LCF125-F)

4

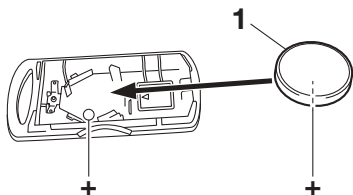

1. Battery

4. Gently snap the smart key case closed.

ECA15785

NOTICE

- Use a cloth when opening the smart key case with a screwdriver. Direct contact with hard objects may damage or scratch the smart key.
- Take precautions to prevent the waterproof seal from being damaged or contaminated by dirt.
- Do not touch the internal circuits and terminals. This may cause malfunctions.

- Do not apply excessive force to the smart key when replacing the battery.
- Make sure the battery is installed correctly. Confirm the direction of the positive “+” side of the battery.

 : This symbol is intended to alert the user to the presence of important operating and maintenance (servicing) instructions in the literature accompanying the appliance.

EWA20633

WARNING

This product contains a coin/button cell battery.

To prevent an explosion or leakage of flammable liquid or gas:

- Do not replace the battery with an incorrect type. Replace only with the same or equivalent type.
- Please check and obey all local laws and regulations for the disposal of batteries or accumulations.

- Do not dispose of any battery with fire, incineration, or by mechanically crushing or cutting the battery.
- Do not store, or put a smart key any place where it may be exposed to extremely high temperatures or extremely low air pressure.
- If a battery is incorrectly discarded or heated to a high temperature (100 °C (212 °F) or higher), gas may be generated inside battery thereby causing electrolyte leakage, internal short circuit, heat generation, explosion and violent flaring.
- Do not expose smart keys to excessive heat such as direct sunlight, fire, etc.

Do not swallow any coin/button cell batteries:

- Do not ingest the battery, chemical burn hazard.

- If the coin/button cell battery is swallowed or placed inside any part of the body, it can cause severe internal burns in just 2 hours and can lead to death.
- Keep new and used batteries away from children. If the smart key does not close securely, stop using the smart key and keep it away from children.
- If you think a battery might have been swallowed or placed inside any part of the body, seek immediate medical attention.

EWA23170

WARNING

- The specified battery is not rechargeable, do not recharge the battery.
- Remove and immediately recycle or dispose of the smart key battery according to local regulations if the smart key will not be used for an extended period of time.
- Always make sure the smart key case is completely closed. If the case does not close securely,

stop using the smart key, remove the battery, and keep them away from children.

- Do not force discharge, recharge, disassemble, heat the battery to 100 °C (212 °F) or higher, or incinerate it. Doing so may result in injury due to venting, leakage or explosion resulting in chemical burns.
- Even used batteries may cause severe injury or death. Immediately recycle or dispose of any used batteries according to local regulations and keep away from children. Do NOT dispose of batteries in household trash or incinerate. If consumed, call a local poison control center for treatment information.

Smartphone Connectivity System

5

CCU (Communication Control Unit) (If equipped)

EUA8361

This vehicle is equipped with a CCU (Communication Control Unit) that enables wireless Bluetooth connection between the vehicle and your smartphone via the Yamaha Motorcycle Connect app. Through this connection, you will receive notifications for SNS (social network service) app alerts, incoming calls, and missed calls, as well as the battery status of your smartphone. Additionally, the Yamaha Motorcycle Connect app offers other features, such as displaying your last parked location.

EWA21413

WARNING

- **Failure to pay attention while riding could result in death or serious injury. Always concentrate on riding by keeping your eyes and mind on the road.**
- **Stop the vehicle before making any settings changes or operating your smartphone.**

- **Changing settings while riding can distract the operator and increase the risk of an accident.**
- **Never take your hands off the handlebars while riding.**

TIP

- The CCU takes some time to initiate and stabilize the Bluetooth connection after the vehicle power is turned on or the vehicle battery is reconnected.
- Some connectivity functions need to be activated on the connected smartphone before they become functional in the menu system.
- Some connectivity functions may not be available depending on your smartphone and/or OS (operating system) version.
- The following may interfere with connectivity functions:
 - Smartphone network connection is too busy.
 - Bluetooth connection is unstable.
 - Too many other devices connected to the smartphone at once.

- The Bluetooth connection may not work in the following situations:
 - In locations exposed to strong radio waves or other electromagnetic noise.
 - Near facilities emitting strong radio waves, such as TV and radio towers, power plants, broadcasting stations, airports, etc.
- Only one smartphone can be connected to the CCU at one time.
- If more than one phone has been registered in the CCU, then the first phone within reach will be connected.

Initial setup: Yamaha Motorcycle Connect app



Smartphone Connectivity System

Yamaha Motorcycle Connect is a free app which is needed to complete the connection between the CCU and your smartphone.

After pairing the CCU and the Yamaha Motorcycle Connect app, the smartphone is registered in the CCU. When the app is connected to the CCU, the smartphone battery level indicator “

Scan the QR code below and download the Yamaha Motorcycle Connect app, or search for it by name in an app store.



The CCU can be paired to your smartphone by:

- Entering the VIN (vehicle identification number) in the Yamaha Motorcycle Connect app. (See page 13-1.)
- Use the Yamaha Motorcycle Connect app to scan the QR code on the CCU.

TIP

- Once paired, the smartphone is registered in the CCU. The next time the vehicle is turned on and the Yamaha Motorcycle Connect app is active, the connection will be automatically established.
- Use of Yamaha Motorcycle Connect is subject to your agreement to the Yamaha Motorcycle Connect terms of use.
- The Yamaha Motorcycle Connect app may not function on all smartphones or OS (operating system) versions.
- Every smartphone operates differently; refer to your individual device instructions regarding connectivity, Bluetooth discovery, app permissions, and other settings.

- Some connectivity and/or display functions may change with later updates to the Yamaha Motorcycle Connect app and therefore differ from the contents of this manual.

Smartphone Connectivity System

EAU2610

Scanning the CCU QR code

To pair your smartphone with the vehicle by scanning the CCU QR code complete the following procedure:

1. Open the seat. (See page 7-15.)
2. Remove the CCU cover.

5

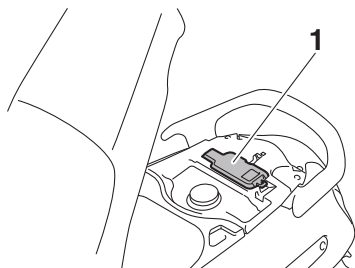

1. CCU cover

3. Pull out the CCU and scan its QR code with your smartphone.

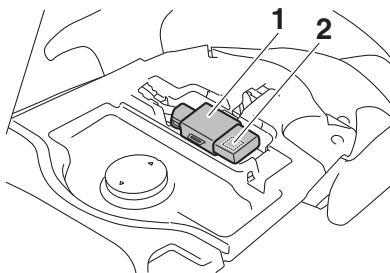

1. CCU (Communication Control Unit)
2. CCU QR Code

4. When pairing is complete, the Yamaha Motorcycle Connect icon and smartphone battery level meter will come on.

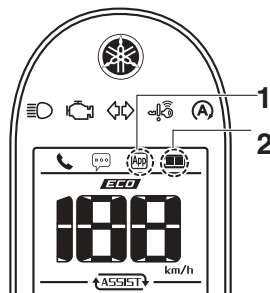

1. Yamaha Motorcycle Connect icon
2. Smartphone battery level meter

TIP

- Once paired, the smartphone is registered in the CCU. The next time the vehicle is turned on and the Yamaha Motorcycle Connect app is active, the connection will be automatically executed.
- Only one smartphone can be connected to the CCU at one time.

Stop and Start System

EAU76826

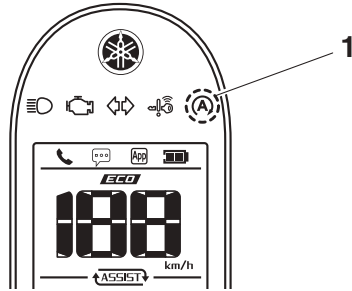

1. Stop and Start System indicator light “(A)”

The Stop and Start System stops the engine automatically when the vehicle is stopped in order to prevent noise, control exhaust emissions, and reduce fuel consumption.

When the rider turns the throttle grip slightly, the engine restarts automatically and the vehicle starts off.

ECA23961

NOTICE

When parking the vehicle or leaving the vehicle unattended, be sure to turn the main switch off. If the Stop and Start System is left turned on, the battery could become dis-

charged and it may not be possible to restart the engine due to insufficient battery voltage.

TIP

- Although the engine normally stops at the same time as the vehicle, there may be a delay when operating the vehicle under 10 km/h, such as in heavy traffic.
- If you think the battery voltage is low because the engine cannot be started using the starter switch or for some other reason, do not turn on the Stop and Start System.
- Have a Yamaha dealer check the battery at the intervals specified in the periodic maintenance chart.

Stop and Start System operation

EAU76671

Activating the Stop and Start System

EAU76687

1. Turn the main switch on.

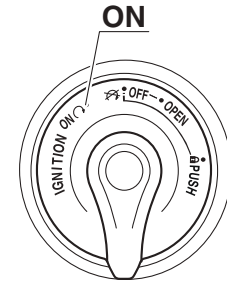

2. Set the Stop and Start System switch to “(A)”.

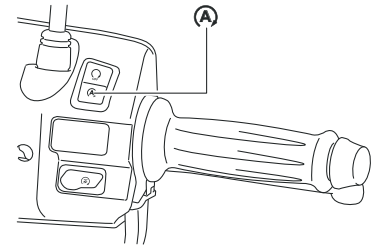

Stop and Start System

3. The Stop and Start System activates and the indicator light comes on when the following conditions are met:

- The Stop and Start System switch is set to “(A)”.
- After the engine was warmed up, the engine was left idling for a certain period.
- The vehicle has traveled at a speed of 10 km/h or higher.

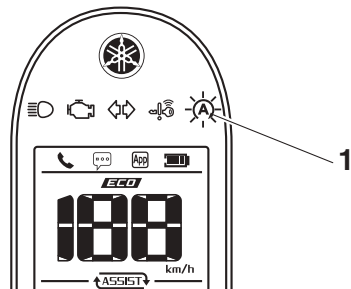

1. On

4. To turn off the Stop and Start System, set the Stop and Start System switch to “(A)”.

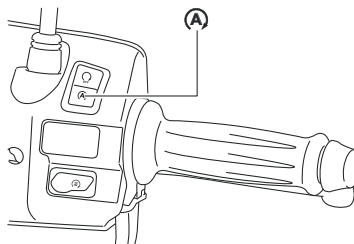

TIP

- To preserve battery power, the Stop and Start System may not activate.
- If the Stop and Start System does not activate, have a Yamaha dealer check the battery.

Stop the engine

The engine will stop automatically when the following conditions are met:

- The Stop and Start System switch is set to “(A)”.
- The Stop and Start System indicator light “(A)” on the multi-function meter is on.
- The vehicle is stopped with the throttle grip fully returned.

At this time, the Stop and Start System indicator light “(A)” starts flashing to indicate that the engine is currently stopped by the Stop and Start System.

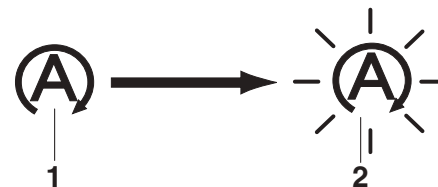

1. On
2. Flashing

Restart the engine

If the throttle grip is turned while the Stop and Start System indicator light “(A)” is flashing, the engine will automatically restart and the light will stop flashing.

EAU76705

EAU76833

Stop and Start System

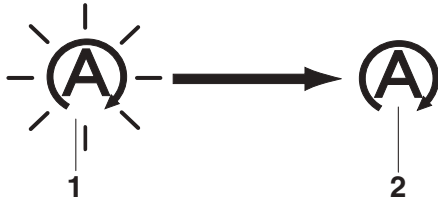

1. Flashing
2. Off

! WARNING

Do not turn the throttle grip too much or too quickly when the Stop and Start System is activated and the engine is stopped. Otherwise, the vehicle could start moving unexpectedly after the engine restarts.

EWA18731



TIP

- When the sidestand is lowered, the Stop and Start System is deactivated.
- If the Stop and Start System does not operate correctly, have a Yamaha dealer check the vehicle.

EAU76711

Precautions when using the Stop and Start System

In order to prevent accidents due to improper operation, carefully read and observe the following precautions.

EWA18741

! WARNING

When walking while pushing the vehicle, be sure to turn the main switch off. If the vehicle is pushed while the

Stop and Start System is left turned on, the engine could start and the vehicle could start moving if the throttle grip is turned accidentally.

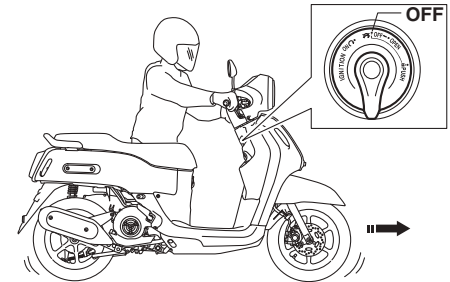

EWA18751

! WARNING

When placing the vehicle on the centerstand, be sure to turn the main switch off. If the vehicle is placed on the centerstand while the Stop and Start System is left turned on, the engine could start and the vehicle could start moving if the throttle grip is turned accidentally.

Stop and Start System

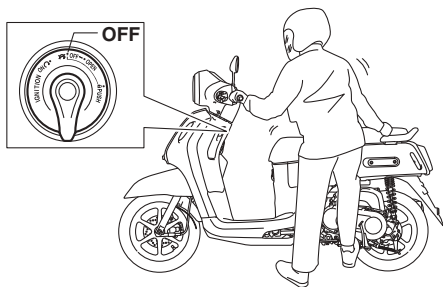

EWA18771

⚠ WARNING

- When leaving the vehicle unattended, be sure to turn the main switch off.
- Do not leave the Stop and Start System turned on when parking the vehicle. Otherwise, the engine could start and the vehicle could start moving if the throttle grip is turned accidentally.

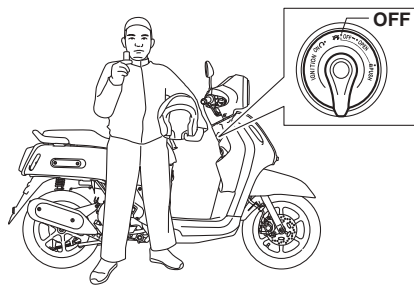

EWA18781

⚠ WARNING

Before performing maintenance, be sure to turn the main switch off. If maintenance is performed while the Stop and Start System is turned on, the engine could start and the vehicle could start moving if the throttle grip is turned.

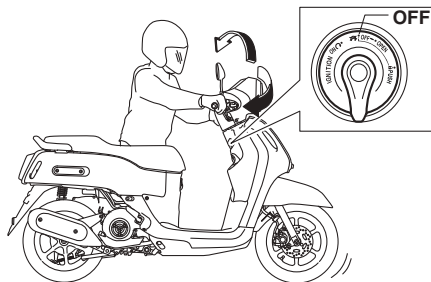

Main switch (LCF125-F)

EUA8783

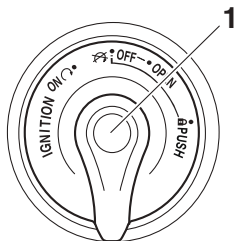

1. Main switch knob

The main switch is used to turn the vehicle power on/off, lock/unlock the steering and open the seat/fuel tank lid. To use the main switch:

1. Push the main switch knob inward. If the smart key is detected within range, the system will activate the main switch for approximately 4 seconds, and the smart key indicator light will come on. (See page 7-5.)
2. While holding the main switch knob in, turn it to the desired position within the 4-second window, before the smart key indicator light goes off.

! WARNING

Never turn the main switch to "OFF", "LOCK", or "OPEN" while the vehicle is moving. Otherwise the electrical systems will be switched off, which may result in loss of control or an accident.

TIP

Do not repeatedly push or turn the main switch knob beyond normal use. Doing so will temporarily disable the smart key system to protect the main switch. When disabled, the smart key system indicator light will blink. If this occurs, wait until the smart key system indicator light stops blinking before operating the main switch again.

The main switch positions are described as follows:

EWA18720

ON

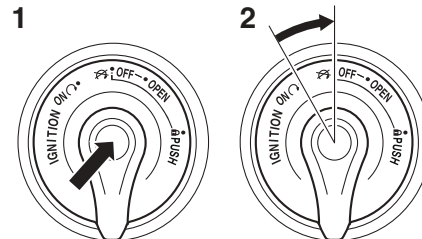

1. Push.
2. Turn.

All electrical circuits are supplied with power, and the engine can be started. When the main switch knob is turned to "ON", all of the turn signal lights will flash twice and the vehicle power will turn on.

TIP

- If the vehicle battery voltage is low, the turn signal lights will not flash.
- See "Emergency mode" on page 10-33 for information on turning the vehicle power on without the smart key.

Instrument and control functions

EAUN5421

OPEN

The seat can be opened.

1. With the smart key on and within operating range, push the main switch knob.
2. While the smart key system indicator light is on, turn the main switch to "OPEN" and then lift the rear of the seat.

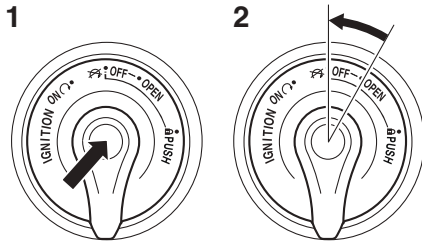

1. Push.
2. Turn.

TIP

- Make sure that the seat is securely closed before starting off.
- The seat can also be opened with the mechanical key. (See page 7-17.)

Open position reminder

To prevent you from accidentally leaving the vehicle unlocked by walking away with the main switch still in the "OPEN" position, the smart key system beeper will sound under the following conditions.

- When the main switch has been in the "OPEN" position for 3 minutes
- If the smart key is turned off while the main switch is in the "OPEN" position
- If you walk out of range of the smart key system with the main switch in the "OPEN" position

If the beeper sounds after 3 minutes, turn the main switch to "OFF" or "LOCK". If the beeper sounds because the smart key was turned off or moved out of range, turn the smart key on and walk back into range.

TIP

The beeper will turn off after 1 minute.

EAUA8670

OFF

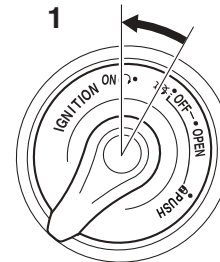

1. Turn.

All electrical systems are off.

When the main switch is turned to "OFF", all the turn signal lights will flash once and the vehicle power turns off.

TIP

When the main switch is turned to "OFF" but the smart key cannot be confirmed (the smart key is either outside operation range or has been turned off), the beeper will sound for 3 seconds and the smart key system indicator light will flash for 30 seconds.

- For 30 seconds, the main switch can be freely operated.
- After 30 seconds, the vehicle power will turn off automatically.

Instrument and control functions

- To turn the vehicle power off immediately, push the main switch knob inward four times within 2 seconds.

“” (Lock)

EAU8771

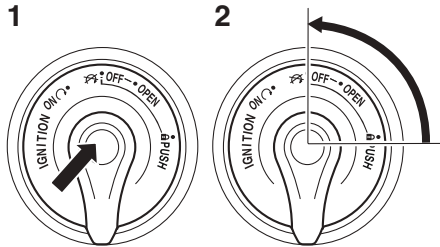

1. Push.
2. Turn.

The steering is locked and all electrical systems are off.

To lock the steering

1. Turn the handlebar all the way to the left.
2. With the smart key turned on and within operating range, push the main switch knob.

3. While the smart key system indicator light is on, push and turn the main switch knob to “”.

TIP

If the steering will not lock, try turning the handlebar back to the right slightly.

EWA14742

WARNING

Do not operate the steering lock while the vehicle is moving.

To unlock the steering

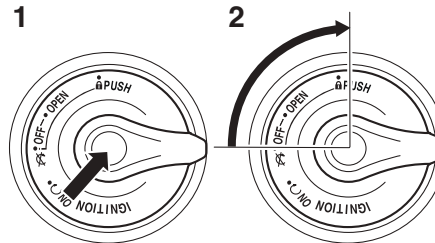

1. Push.
2. Turn.

1. With the smart key turned on and within operating range, push the main switch knob.

Instrument and control functions

Main switch/steering lock

EAUN0264

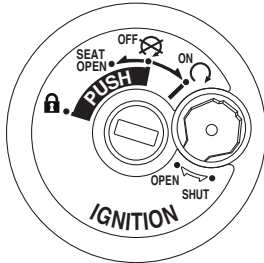

The main switch/steering lock controls the ignition and lighting systems, and is used to lock the steering. The various main switch positions are described below.

TIP

The main switch/steering lock is equipped with a keyhole shutter. (See page 7-5 for keyhole shutter opening and closing procedures.)

EAUV0191

ON

All electrical circuits are supplied with power, and the engine can be started. The key cannot be removed.

TIP

- The meter lighting comes on automatically when the key is turned to “ON”.
- The fuel pump can be heard when the key is turned to “ON”.

EAU10664

OFF

All electrical systems are off. The key can be removed.

EWA10062



Never turn the key to “OFF” or “LOCK” while the vehicle is moving. Otherwise the electrical systems will be switched off, which may result in loss of control or an accident.

EAU43143

LOCK

The steering is locked, and all electrical systems are off. The key can be removed.

To lock the steering

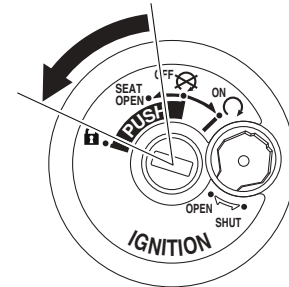

1. Turn the handlebars all the way to the left.
2. Push the key in from the “OFF” position, and then turn it to “LOCK” while still pushing it.
3. Remove the key.

TIP

If the steering will not lock, try turning the handlebars back to the right slightly.

To unlock the steering

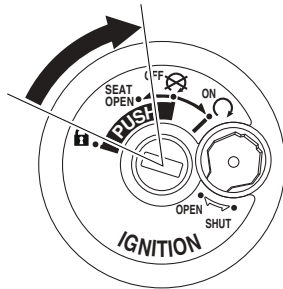

Insert the key and turn it to “OFF”.

Keyhole shutter

EAU68160

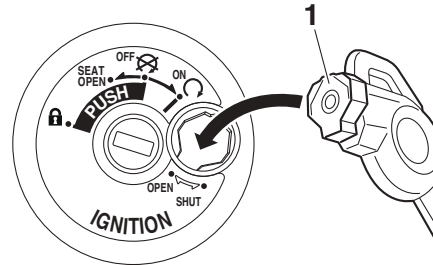

1. Key head

To open the keyhole shutter

Insert the key head into the keyhole shutter receptacle as shown, and then turn the key to “OPEN” to open the keyhole shutter.

To close the keyhole shutter

Insert the key head into the keyhole shutter receptacle as shown, and then turn the key to “SHUT” to close the keyhole shutter.

Indicator lights and warning lights





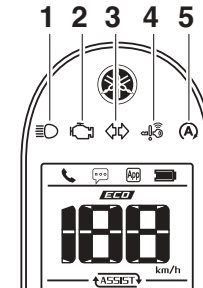

EAU7712D

ECA29090

NOTICE

If an indicator or warning is signaling a problem or abnormal condition, then stop all vehicle operation immediately. Have a Yamaha dealer inspect the vehicle.



1. High beam indicator light “”
2. Engine trouble warning light “”
3. Turn signal indicator light “ ”
4. Smart key system indicator light “” (LCF125-F)
5. Stop and Start System indicator light “”

Turn signal indicator light “ ”

EAU11022

This indicator light flashes when a turn signal light is flashing.

Instrument and control functions

High beam indicator light “” EAU11081

This indicator light comes on when the high beam of the headlight is switched on.

Engine trouble warning light “” EAU77562

This warning light comes on if a problem is detected in the engine or other vehicle control system. If this occurs, have a Yamaha dealer check the on-board diagnostic system.

TIP _____

When the vehicle is turned on, this light should come on for a few seconds and then go off. Otherwise, have a Yamaha dealer check the vehicle.

Smart key system indicator light “” EAU78602

This indicator light communicates the status of the smart key system. When the smart key system is operating normally, this indicator light will be off. If there is an error in the smart key system, the indicator light will flash. The indicator light will also flash when communication between the vehicle and

smart key takes place and when certain smart key system operations are carried out.

Stop and Start System indicator light “” EAU76382

This indicator light comes on when the Stop and Start System activates. The indicator light will flash when the engine is automatically stopped by the Stop and Start System.

TIP _____

Even if the Stop and Start Switch is set to “”, this indicator light may not come on. (See page 6-1.)

Incoming call indicator light “” EAUN4300 (If CCU is equipped)

This indicator light flashes when there is an incoming call to the connected smartphone. If you do not answer the call, the indicator light stays on until you turn the vehicle off.

TIP _____

This function works only when the smartphone is connected to the vehicle.

Incoming notification indicator light “” (If CCU is equipped) EAUN4310

This indicator light flashes for 10 seconds when the connected smartphone receives an SNS, E-mail or other notification. After that, the indicator light stays on until you turn the vehicle off.

TIP _____

- This function works only when the smartphone is connected to the vehicle.
- Notification setting is needed for each application at the connected smartphone in advance.

Multi-function meter unit

EAUN3473

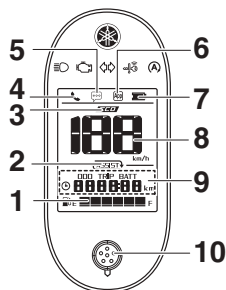

1. Fuel meter
2. ASSIST indicator
3. Eco indicator “ECO”
4. Incoming call indicator light “☎”
5. Notification indicator light “💬”
6. Yamaha Motorcycle Connect icon
7. Smartphone battery level meter
8. Speedometer
9. Multi-function display
10. “SEL/RES” button

WARNING

Be sure to stop the vehicle before making any setting changes to the multi-function meter unit. Changing

EWA12423

settings while riding can distract the operator and increase the risk of an accident.

TIP

Be sure to turn the main switch on before using the “SEL/RES” button.

Yamaha Motorcycle Connect icon (If CCU is equipped)

EAUA1370

This icon comes on when CCU and smartphone are connected via the Yamaha Motorcycle Connect app.

TIP

If CCU is equipped: Even if the smartphone is not connected, when the vehicle is turned on, this icon should come on for a few seconds. Otherwise have a Yamaha dealer check the CCU and the electrical circuit.

Smartphone battery level meter (If CCU is equipped)

EAUA1390

This meter indicates the current battery level of the connected smartphone. The display segments of the meter dis-

appear from full to blank as the battery level decreases. When approximately 10% or less of the battery remains, the last segment starts flashing.

TIP

If CCU is equipped: Even if the smartphone is not connected, when the vehicle is turned on, this icon should come on for a few seconds. Otherwise have a Yamaha dealer check the CCU and the electrical circuit.

Speedometer

EAU86831

7

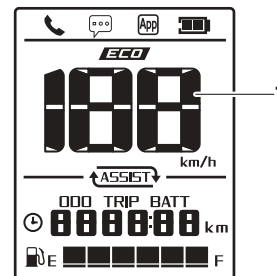

1. Speedometer

The speedometer shows the vehicle's traveling speed.

Instrument and control functions

Fuel meter

EAU86842

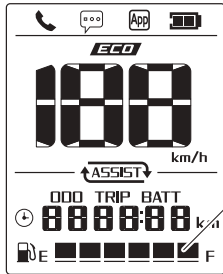

1. Fuel meter

The fuel meter indicates the amount of fuel in the fuel tank. The display segments of the fuel meter disappear from “F” (full) towards “E” (empty) as the fuel level decreases. When approximately 0.2 L (0.07 US gal, 0.06 Imp.gal) of fuel remains, the last segment starts flashing. Refuel as soon as possible.

TIP

If a problem is detected in the electrical circuit, the fuel level segments will flash repeatedly. If this occurs, have a Yamaha dealer check the vehicle.

NOTICE

Do not let the vehicle run completely out of fuel. This may cause damage to the catalytic converter.

Multi-function display

EAUN3480

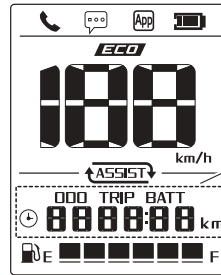

1. Multi-function display

The multi-function display is equipped with the following:

- an odometer (ODO)
- a tripmeter (TRIP)
- a clock
- a battery voltage display (BATT)

Push the “SEL/RES” button to change the display in the following order:

ECAE0121

ODO → TRIP → CLOCK → BATT → ODO

Odometer

EAU86891

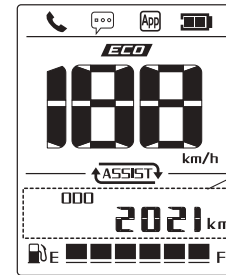

1. Odometer

The odometer shows the total distance traveled by the vehicle.

TIP

The odometer will lock at “999999” and cannot be reset.

Tripmeter

EAUN3491

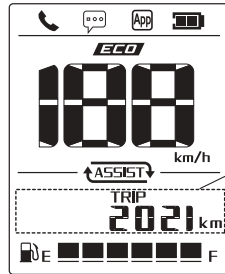

1. Tripmeter

The tripmeter shows the distance traveled since it was last reset.

To reset the tripmeter, set the display to the tripmeter, and then hold the “SEL/RES” button until it is reset.

TIP

The tripmeter will reset and continue counting after 9999.9 is reached.

Clock

EAUE4550

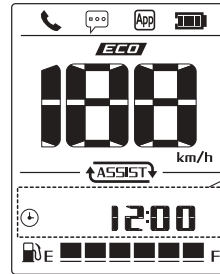

1. Clock

The clock uses a 12-hour time system.

To set the clock

1. Use the “SEL/RES” button to change the display to the clock.
2. Hold the “SEL/RES” button until the hour digits start flashing.
3. Use the “SEL/RES” button to set the hours.
4. Hold the “SEL/RES” button until the minute digits start flashing.
5. Use the “SEL/RES” button to set the minutes.
6. Hold the “SEL/RES” button to confirm the settings.

TIP

When CCU and smartphone is connected after vehicle power on, the clock is automatically adjusted.

Battery voltage display

EAU86960

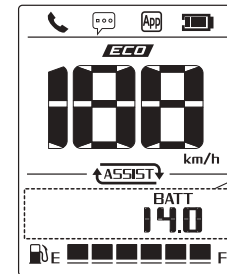

1. Battery voltage meter

This display shows the current charge state of the battery.

- Over 12.8 V = Full charge.
- Under 12.7 V = Charging is required.

TIP

If the battery voltage is less than 9.0 V, “_ _ _” is displayed.

Instrument and control functions

SMG assist icon

EAUN3500

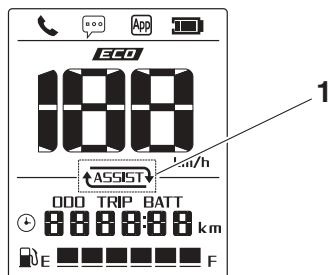

1. SMG assist icon

This vehicle is equipped with a Smart Motor Generator (SMG) that not only starts the engine, but also assists with initial acceleration.

When SMG is active, moving arrows will appear around the ASSIST icon.

TIP _____
When battery voltage is low, the smart motor generator may not assist with acceleration.

Eco indicator

EAU90821

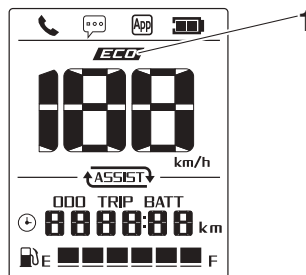

1. Eco indicator "ECO"

This indicator comes on when the vehicle is being operated in an environmentally friendly, fuel-efficient manner. The indicator goes off when the vehicle is stopped.

TIP _____
Consider the following tips to reduce fuel consumption:

- Avoid high engine speeds during acceleration.
- Travel at a constant speed.
- Select the transmission gear that is appropriate for the vehicle speed.

Handlebar switches

EAU1234U

Left

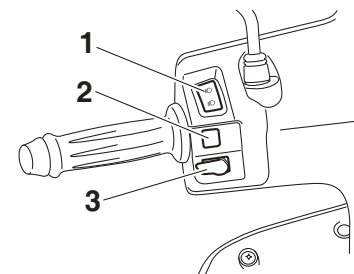

1. Dimmer switch "☰/☷"
2. Turn signal switch "←/→"
3. Horn switch "📢"

Right

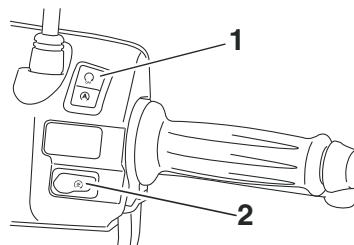

1. Stop and Start System switch "Ⓐ/Ⓐ OFF"
2. Start switch "🌀"

Dimmer switch “☰/☷”

EAU12402

Set this switch to “☰” for the high beam and to “☷” for the low beam.

Turn signal switch “↔/↔”

EAU12461

To signal a right-hand turn, push this switch to “↔”. To signal a left-hand turn, push this switch to “↔”. When released, the switch returns to the center position. To cancel the turn signal lights, push the switch in after it has returned to the center position.

Horn switch “🔊”

EAU12501

Press this switch to sound the horn.

Start switch “🔌”

EAU12722

With the sidestand up, push this switch while applying the front or rear brake to crank the engine with the starter. See page 9-2 for starting instructions prior to starting the engine.

Stop and Start System switch

EAU76391

“(A)/_{OFF}(A)”

To turn on the Stop and Start System, set the switch to “(A)”. To turn off the Stop and Start System, set this switch to “_{OFF}(A)”.

Front brake lever

EAU12902

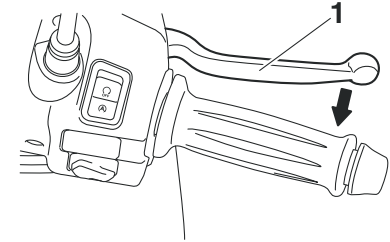

1. Front brake lever

The front brake lever is located on the right side of the handlebar. To apply the front brake, pull this lever toward the throttle grip.

Instrument and control functions

Rear brake lever

EAUS1964

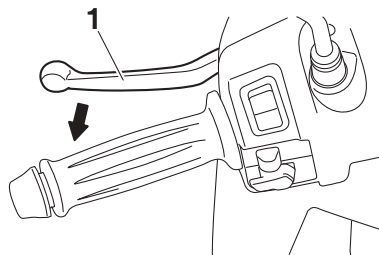

1. Rear brake lever

The rear brake lever is located on the left side of the handlebar. To apply the rear brake, pull the lever toward the handlebar grip.

This model is equipped with a unified brake system.

When pulling the rear brake lever, the rear brake and a portion of the front brake are applied. For full braking performance, apply both brake levers simultaneously.

TIP

- As the unified brake system is mechanical, additional free play can be felt in the front brake lever when the rear brake lever is being pulled.
- The unified brake system does not function when the front brake is applied alone.

Fuel tank cap

EAU37474

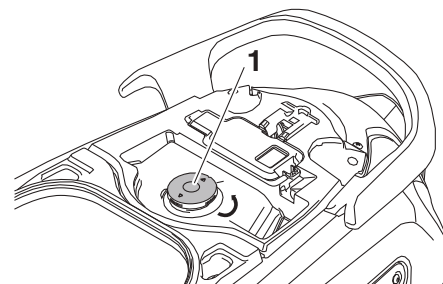

1. Fuel tank cap

To remove the fuel tank cap

1. Open the seat. (See page 7-15.)
2. Turn the fuel tank cap counter-clockwise and pull it off.

To install the fuel tank cap

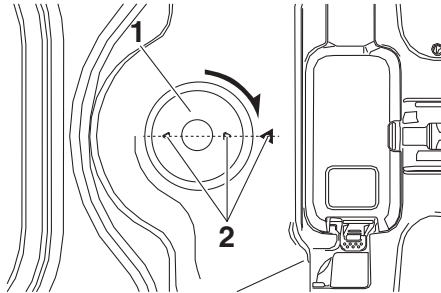

1. Fuel tank cap
2. “△” mark

1. Insert the fuel tank cap into the tank opening and turn it clockwise until the “△” marks on the cap and tank cover are aligned.
2. Close the seat.

EWA11092

WARNING

Make sure that the fuel tank cap is properly closed after filling fuel. Leaking fuel is a fire hazard.

Fuel

Make sure there is sufficient gasoline in the tank.

EAU13213

EWA10882

WARNING

Gasoline and gasoline vapors are extremely flammable. To avoid fires and explosions and to reduce the risk of injury when refueling, follow these instructions.

1. Before refueling, turn off the engine and be sure that no one is sitting on the vehicle. Never refuel while smoking, or while in the vicinity of sparks, open flames, or other sources of ignition such as the pilot lights of water heaters and clothes dryers.
2. Do not overfill the fuel tank. Stop filling when the fuel reaches the bottom of the filler tube. Because fuel expands when it heats up, heat from the engine or the sun can cause fuel to spill out of the fuel tank.

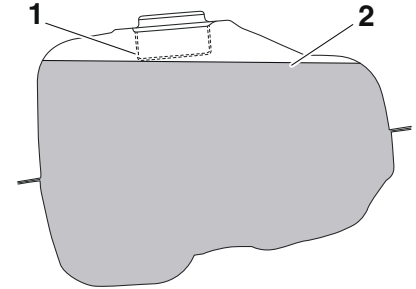

1. Fuel tank filler tube
2. Maximum fuel level

3. Wipe up any spilled fuel immediately. **NOTICE: Immediately wipe off spilled fuel with a clean, dry, soft cloth, since fuel may deteriorate painted surfaces or plastic parts.** [ECA10072]
4. Be sure to securely close the fuel tank cap.

EWA15152

WARNING

Gasoline is poisonous and can cause injury or death. Handle gasoline with care. Never siphon gasoline by mouth. If you should swallow some gasoline or inhale a lot of gasoline vapor, or get some gasoline in your eyes, see your doctor immedi-

Instrument and control functions

ately. If gasoline spills on your skin, wash with soap and water. If gasoline spills on your clothing, change your clothes.

EAUJ0045

Recommended fuel:

Regular unleaded gasoline (E10 to E20 only)

Fuel tank capacity:

5.1 L (1.3 US gal, 1.1 Imp.gal)

ECA11401

7

NOTICE

Use only unleaded gasoline. The use of leaded gasoline will cause severe damage to internal engine parts, such as the valves and piston rings, as well as to the exhaust system.

Gasohol

There are two types of gasohol: gasohol containing ethanol and that containing methanol. Gasohol containing ethanol can be used if the ethanol content does not exceed 10% (E10). Gasohol containing methanol is not

recommended by Yamaha because it can cause damage to the fuel system or vehicle performance problems.

EAU13435

Catalytic converter

The exhaust system contains catalytic converter(s) to reduce harmful exhaust emissions.

EWA10863

WARNING

The exhaust system is hot after operation. To prevent a fire hazard or burns:

- Do not park the vehicle near possible fire hazards such as grass or other materials that easily burn.
 - Park the vehicle in a place where pedestrians or children are not likely to touch the hot exhaust system.
 - Make sure that the exhaust system has cooled down before doing any maintenance work.
 - Do not allow the engine to idle more than a few minutes. Long idling can cause a build-up of heat.
-

Kickstarter (LCF125-C)

EAU37652

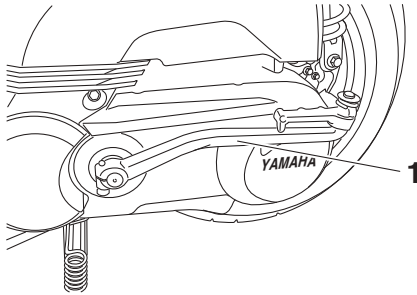

1. Kickstarter

If the engine fails to start by pushing the start switch, try to start it by using the kickstarter. To start the engine, fold out the kickstarter lever, move it down lightly with your foot until the gears engage, and then push it down smoothly but forcefully.

Seat

EAUJ2240

ECA24020

To open the seat (LCF125-F)

Via the main switch

Push the main switch knob and then turn it to “OPEN”. (See page 7-2.)

With the mechanical key

1. Open the keyhole cover.
2. Insert the mechanical key into the seat lock, and then turn it clockwise.

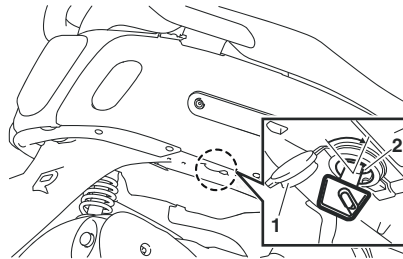

1. Keyhole cover
2. Unlock.

3. Lift the rear of the seat.

NOTICE

Make sure that the keyhole cover is installed when the mechanical key is not being used.

To open the seat (LCF125-C)

1. Insert the key into the main switch, and then turn it counterclockwise to “SEAT OPEN”.

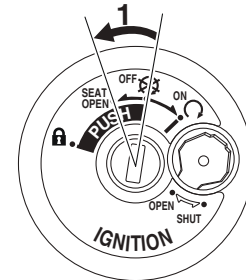

1. Open.

TIP

Do not push inward when turning the key.

2. Lift the rear of the seat.

Instrument and control functions

To close the seat

Push the rear of the seat down to lock it in place.

TIP

Make sure that the seat is properly secured before riding.

Helmet holders

EAU37482

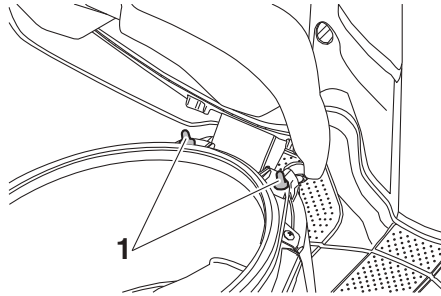

1. Helmet holder

The helmet holders are located under the seat.

To release a helmet from a helmet holder

Open the seat, remove the helmet from the helmet holder, and then close the seat.

To secure a helmet to a helmet holder

1. Open the seat. (See page 7-15.)
2. Attach a helmet to a helmet holder, and then securely close the seat. **WARNING! Never ride with a helmet attached to the helmet holder, since the helmet may hit objects, causing loss of control and possibly an accident.** [EWA10162]

Storage compartments

EAUJ2600

This model is equipped with 3 storage compartments. The front storage compartments and rear storage compartment are located as shown.

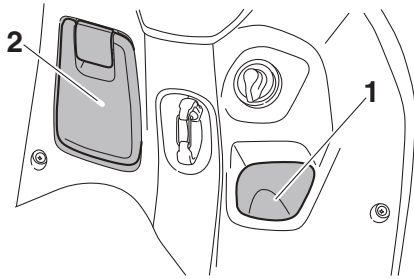

1. Storage compartment A
2. Storage compartment B

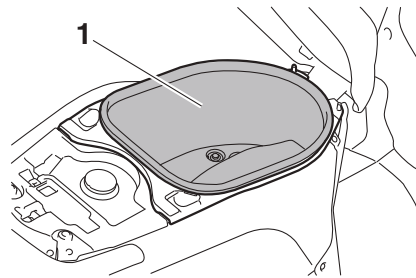

1. Rear storage compartment

TIP

Some helmets cannot be stored in the rear storage compartment because of their size or shape.

Storage compartment B

To open storage compartment B, pull up the storage compartment lid to unlock it, and then open.

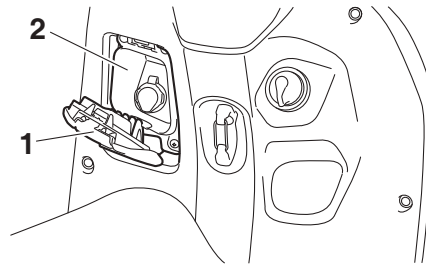

1. Lid
2. Storage compartment B

To close storage compartment B, push the storage compartment lid into the original position.

Rear storage compartment

The rear storage compartment is located under the seat. Use this compartment for large items. (See page 7-15.)

TIP

Do not leave your vehicle unattended with the seat open.

ECA21150

NOTICE

Keep the following points in mind when using the storage compartment.

- Since the storage compartment accumulates heat when exposed to the sun and/or the engine heat, do not store anything susceptible to heat, consumables or flammable items inside it.
- To avoid humidity from spreading through the storage compartment, wrap wet articles in a plastic bag before storing them in the compartment.

Instrument and control functions

- Since the storage compartment may get wet while the vehicle is being washed, wrap any articles stored in the compartment in a plastic bag.
- Do not keep anything valuable or breakable in the storage compartment.

WARNING

EWA18950

- Do not exceed the load limit of 0.5 kg (1.1 lb) for storage compartment A.
- Do not exceed the load limit of 0.5 kg (1.1 lb) for storage compartment B.
- Do not exceed the load limit of 5.0 kg (11 lb) for the rear storage compartment.
- Do not exceed the maximum load of 158 kg (348 lb) for the vehicle.

Luggage hook

EAUT1073

EWAT1032

WARNING

- Do not exceed the load limit of 1.0 kg (2.2 lb) for the luggage hook.
- Do not exceed the maximum load of 158 kg (348 lb) for the vehicle.

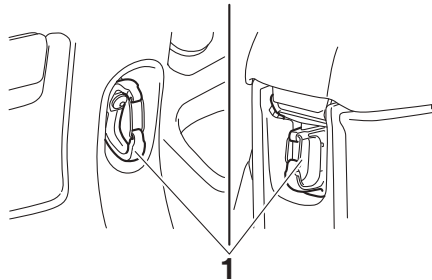

1. Luggage hook

USB Type-A jack

EAU1770

This model is equipped with a 5V 2A USB Type-A jack. The USB Type-A jack can be used when the main switch is on.

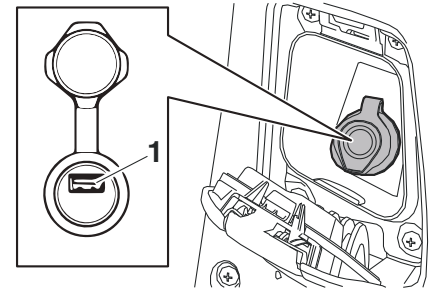

1. USB Type-A jack

TIP

Under some conditions, the device battery level may drop even while the USB is plugged in.

NOTICE

ECAV0100

- Do not use the USB Type-A jack to charge devices such as phones or mobile batteries in-

side the rear storage compartment while riding. Doing so may cause the device to overheat.

- **To protect the USB Type-A jack from water and collisions, install the cap when the jack is not being used. If the USB Type-A jack gets wet, please dry it with the vehicle turned off before using it.**
- **To prevent damage, avoid applying excessive force when opening and closing the USB jack cap.**
- **Do not put tension or apply force to cables attached to the USB Type-A jack as it may cause damage.**

EAU15306

Sidestand

The sidestand is located on the left side of the frame. Raise the sidestand or lower it with your foot while holding the vehicle upright.

TIP

The built-in sidestand switch is part of the ignition circuit cut-off system, which cuts the ignition in certain situations. (See the following section for an explanation of the ignition circuit cut-off system.)

EWA10242

WARNING

The vehicle must not be ridden with the sidestand down, or if the sidestand cannot be properly moved up (or does not stay up), otherwise the sidestand could contact the ground and distract the operator, resulting in a possible loss of control. Yamaha's ignition circuit cut-off system has been designed to assist the operator in fulfilling the responsibility of raising the sidestand before starting off. Therefore, check

this system regularly and have a Yamaha dealer repair it if it does not function properly.

Instrument and control functions

EAUT1098

Ignition circuit cut-off system

Check the operation of the sidestand switch according to the following procedure.

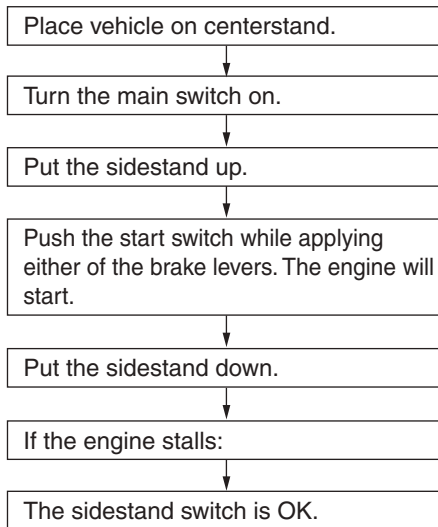

WARNING

- The vehicle must be placed on the centerstand during this inspection.
- If a malfunction is found, have the vehicle inspected before riding.

For your safety – pre-operation checks

EAU1559B

Inspect your vehicle each time you use it to make sure the vehicle is in safe operating condition. Always follow the inspection and maintenance procedures and schedules described in the Owner's Manual.

EWA11152

WARNING

Failure to inspect or maintain the vehicle properly increases the possibility of an accident or equipment damage. Do not operate the vehicle if you find any problem. If a problem cannot be corrected by the procedures provided in this manual, have the vehicle inspected by a Yamaha dealer.

Before using this vehicle, check the following points:

| ITEM | CHECKS | PAGE |
|-------------------------------|---|--------------|
| Fuel | <ul style="list-style-type: none">• Check fuel level in fuel tank.• Refuel if necessary.• Check fuel line for leakage.• Check fuel tank overflow hose for obstructions, cracks or damage, and check hose connection. | 7-13 |
| Engine oil | <ul style="list-style-type: none">• Check oil level in engine.• If necessary, add recommended oil to specified level.• Check vehicle for oil leakage. | 10-10 |
| Final transmission oil | <ul style="list-style-type: none">• Check vehicle for oil leakage. | 10-13 |
| Front brake | <ul style="list-style-type: none">• Check operation.• If soft or spongy, have Yamaha dealer bleed hydraulic system.• Check brake pads for wear.• Replace if necessary.• Check fluid level in reservoir.• If necessary, add specified brake fluid to specified level.• Check hydraulic system for leakage. | 10-20, 10-21 |

For your safety – pre-operation checks

| ITEM | CHECKS | PAGE |
|--|---|--------------|
| Rear brake | <ul style="list-style-type: none"> • Check operation. • If soft or spongy, have Yamaha dealer bleed hydraulic system. • Check brake pads for wear. • Replace if necessary. • Check fluid level in reservoir. • If necessary, add specified brake fluid to specified level. • Check hydraulic system for leakage. | 10-20, 10-21 |
| Throttle grip | <ul style="list-style-type: none"> • Make sure that operation is smooth. • Check throttle grip free play. • If necessary, have Yamaha dealer adjust throttle grip free play and lubricate cable and grip housing. | 10-16, 10-23 |
| Control cables | <ul style="list-style-type: none"> • Make sure that operation is smooth. • Lubricate if necessary. | 10-23 |
| Wheels and tires | <ul style="list-style-type: none"> • Check for damage. • Check tire condition and tread depth. • Check air pressure. • Correct if necessary. | 10-17, 10-19 |
| Brake levers | <ul style="list-style-type: none"> • Make sure that operation is smooth. • Lubricate lever pivoting points if necessary. | 10-23 |
| Centerstand, sidestand | <ul style="list-style-type: none"> • Make sure that operation is smooth. • Lubricate pivots if necessary. | 10-24 |
| Chassis fasteners | <ul style="list-style-type: none"> • Make sure that all nuts, bolts and screws are properly tightened. • Tighten if necessary. | — |
| Instruments, lights, signals and switches | <ul style="list-style-type: none"> • Check operation. • Correct if necessary. | — |
| Sidestand switch | <ul style="list-style-type: none"> • Check operation of ignition circuit cut-off system. • If system is not working correctly, have Yamaha dealer check vehicle. | 7-19 |

Operation and important riding points

EAU15952

Read the Owner's Manual carefully to become familiar with all controls. If there is a control or function you do not understand, ask your Yamaha dealer.

EWA10272

WARNING

Failure to familiarize yourself with the controls can lead to loss of control, which could cause an accident or injury.

EAU16842

Engine break-in

There is never a more important period in the life of your engine than the period between 0 and 1600 km (1000 mi). For this reason, you should read the following material carefully.

Since the engine is brand new, do not put an excessive load on it for the first 1600 km (1000 mi). The various parts in the engine wear and polish themselves to the correct operating clearances. During this period, prolonged full-throttle operation or any condition that might result in engine overheating must be avoided.

EAUM2012

0–1000 km (0–600 mi)

Avoid prolonged operation above 1/3 throttle. **NOTICE: After 1000 km (600 mi) of operation, be sure to replace the engine oil and final transmission oil.** [ECA11662]

1000–1600 km (600–1000 mi)

Avoid prolonged operation above 1/2 throttle.

1600 km (1000 mi) and beyond

The vehicle can now be operated normally.

ECA10271

NOTICE

If any engine trouble should occur during the engine break-in period, immediately have a Yamaha dealer check the vehicle.

Operation and important riding points

Starting the engine

EAU86761

The ignition circuit cut-off system will enable starting when the sidestand is be up.

To start the engine

1. Turn the main switch on.
2. Confirm the indicator and warning light(s) come on for a few seconds, and then go off. (See page 7-5.)

TIP

Do not start the engine if the engine trouble warning light remains on.

ECA26710

NOTICE

Do not continue to operate the vehicle if a warning light remains on. Have a Yamaha dealer check the vehicle.

3. Close the throttle completely.
4. While applying the front or rear brake, push the start switch.

5. Release the start switch when the engine starts, or after 5 seconds. Wait 10 seconds before pressing the switch again to allow battery voltage to restore.

ECA11043

NOTICE

For maximum engine life, never accelerate hard when the engine is cold!

EAUN0073

ECAN0072

NOTICE

Do not ride through deep water, otherwise the engine may be damaged. Avoid puddles because they may be deeper than expected.

Operation and important riding points

Starting off

EAU45093

1. While pulling the rear brake lever with your left hand and holding the grab bar with your right hand, push the scooter off the center-stand.

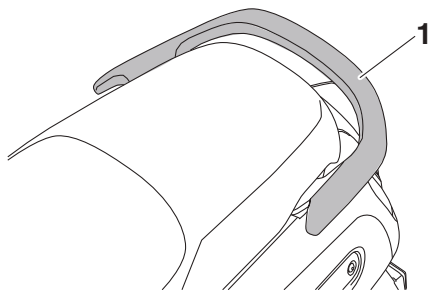

1. Grab bar

9

2. Sit astride the seat, and then adjust the rear view mirrors.
3. Switch the turn signals on.
4. Check for oncoming traffic, and then slowly turn the throttle grip (on the right) in order to take off.
5. Switch the turn signals off.

Acceleration and deceleration

EAU16783

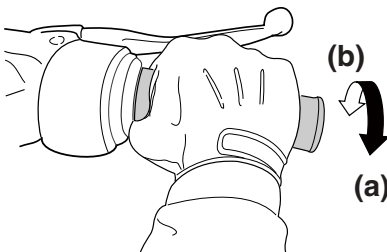

ZAJUM0199

The speed can be adjusted by opening and closing the throttle. To increase the speed, turn the throttle grip in direction (a). To reduce the speed, turn the throttle grip in direction (b).

ECA12682

NOTICE

- Use the brake when stopping on an uphill slope. Holding the vehicle at a stop with throttle operation will cause the clutch to heat up, causing damage to the clutch.

- Do not rev the throttle unnecessarily, otherwise the malfunction indicator light (MIL)/engine trouble warning light may come on.

Braking

EAU60650

EWA17790

WARNING

- **Avoid braking hard or suddenly (especially when leaning over to one side), otherwise the vehicle may skid or overturn.**
- **Railroad crossings, streetcar rails, iron plates on road construction sites, and manhole covers become extremely slippery when wet. Therefore, slow down when approaching such areas and cross them with caution.**
- **Keep in mind that braking on a wet road is much more difficult.**
- **Ride slowly down a hill, as braking downhill can be very difficult.**

1. Close the throttle completely.
2. Apply both front and rear brakes simultaneously while gradually increasing the pressure.

Tips for reducing fuel consumption

EAU16821

Fuel consumption depends largely on your riding style. Consider the following tips to reduce fuel consumption:

- Avoid high engine speeds during acceleration.
- Avoid high engine speeds with no load on the engine.
- Turn the engine off instead of letting it idle for an extended length of time (e.g., in traffic jams, at traffic lights or at railroad crossings).

Parking

EAUW4894

When parking, turn the vehicle power off. After turning off the main switch, be sure to turn off the smart key and take it with you.

WARNING

EWA18840

- **Since the engine and exhaust system can become very hot, park in a place where pedestrians or children are not likely to touch them and be burned.**
- **Do not park on a slope or on soft ground, otherwise the vehicle may overturn, increasing the risk of a fuel leak and fire.**
- **Do not park near grass or other flammable materials which might catch fire.**
- **If the Stop and Start System is left turned on, the battery could become discharged and it may not be possible to restart the engine due to insufficient battery voltage.**

Operation and important riding points

TIP _____

Even when the vehicle is parked in a location partitioned by a fence or the glass window of a shop, if the smart key is within operating range, other people will be able to start the engine and operate the vehicle. Please turn the smart key off when leaving the vehicle. (See page 4-3.)

EAU17246

Periodic inspection, adjustment, and lubrication will keep your vehicle in the safest and most efficient condition possible. Safety is an obligation of the vehicle owner/operator. The most important points of vehicle inspection, adjustment, and lubrication are explained on the following pages.

The intervals given in the periodic maintenance charts should be simply considered as a general guide under normal riding conditions. However, depending on the weather, terrain, geographical location, and individual use, the maintenance intervals may need to be shortened.

EWA10322

! WARNING

Failure to properly maintain the vehicle or performing maintenance activities incorrectly may increase your risk of injury or death during service or while using the vehicle. If you are not familiar with vehicle service, have a Yamaha dealer perform service.

EWA15123

! WARNING

Turn off the engine when performing maintenance unless otherwise specified.

- **A running engine has moving parts that can catch on body parts or clothing and electrical parts that can cause shocks or fires.**
- **Running the engine while servicing can lead to eye injury, burns, fire, or carbon monoxide poisoning – possibly leading to death. See page 2-3 for more information about carbon monoxide.**

EWA15461

! WARNING

Brake discs, calipers, drums, and linings can become very hot during use. To avoid possible burns, let brake components cool before touching them.

EAU85230

Tool kit

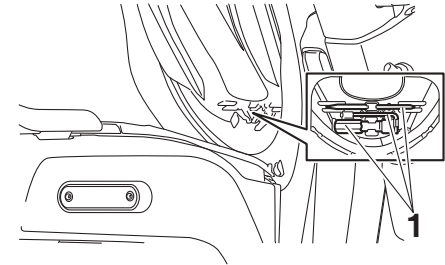

1. Tool kit

The tool kit is in the location shown. The information included in this manual and the tools provided in the tool kit are intended to assist you in the performance of preventive maintenance and minor repairs. However, a torque wrench and other tools are necessary to perform certain maintenance work correctly.

TIP

If you do not have the tools or experience required for a particular job, have your Yamaha dealer perform it for you.

Periodic maintenance and adjustment

EAUU0621

TIP

- The annual checks must be performed every year, except if a kilometer-based maintenance is performed instead.
- From 20000 km, repeat the maintenance intervals starting from 4000 km.
- Items marked with an asterisk should be performed by a Yamaha dealer as they require special tools, data and technical skills.

EAUU2431

Periodic maintenance chart for the emission control system

| NO. | ITEM | CHECK OR MAINTENANCE JOB | ODOMETER READING (whichever comes first) | | | | | ANNUAL CHECK |
|-----|------------------|--|--|---------------------------|---------------------------|-----------------------------|-----------------------------|--------------|
| | | | 1000 km or 1 month | 4000 km or 4 months | 8000 km or 8 months | 12000 km or 12 months | 16000 km or 16 months | |
| 1 | * Fuel line | <ul style="list-style-type: none"> • Check fuel hoses for cracks or damage. | | √ | √ | √ | √ | √ |
| 2 | * Fuel filter | <ul style="list-style-type: none"> • Check condition. • Replace if necessary. | Every 12000 km (7500 mi) | | | | | |
| 3 | Spark plug | <ul style="list-style-type: none"> • Check condition. • Clean and regap. | | √ | √ | √ | √ | |
| | | <ul style="list-style-type: none"> • Replace. | Every 6000 km (3500 mi) | | | | | |
| 4 | * Valves | <ul style="list-style-type: none"> • Check valve clearance. • Adjust if necessary. | | | √ | | √ | |
| 5 | * Fuel injection | <ul style="list-style-type: none"> • Check engine idle speed. | | √ | √ | √ | √ | √ |
| 6 | * Exhaust system | <ul style="list-style-type: none"> • Check for leakage. • Tighten if necessary. • Replace gasket(s) if necessary. | | √ | √ | √ | √ | √ |

Periodic maintenance and adjustment

EAUJ2441

General maintenance and lubrication chart

| NO. | ITEM | CHECK OR MAINTENANCE JOB | ODOMETER READING (whichever comes first) | | | | | ANNUAL CHECK |
|-----|----------------------------------|--|--|---------------------------|---------------------------|-----------------------------|-----------------------------|--------------|
| | | | 1000 km or 1 month | 4000 km or 4 months | 8000 km or 8 months | 12000 km or 12 months | 16000 km or 16 months | |
| 1 | * Diagnostic system check | <ul style="list-style-type: none"> Perform dynamic inspection using Yamaha diagnostic tool. Check the error codes. | √ | √ | √ | √ | √ | √ |
| 2 | Air filter element | <ul style="list-style-type: none"> Replace. | Every 16000 km (10000 mi) | | | | | |
| 3 | Air filter check hose | <ul style="list-style-type: none"> Clean. | √ | √ | √ | √ | √ | |
| 4 | * V-belt case air filter element | <ul style="list-style-type: none"> Clean. Replace if necessary. | | √ | √ | √ | √ | |
| 5 | * Battery | <ul style="list-style-type: none"> Check voltage. Charge if necessary. | √ | √ | √ | √ | √ | √ |
| 6 | * Front brake | <ul style="list-style-type: none"> Check operation, fluid level and vehicle for fluid leakage. | √ | √ | √ | √ | √ | √ |
| | | <ul style="list-style-type: none"> Replace brake pads. | Whenever worn to the limit | | | | | |
| 7 | * Rear brake | <ul style="list-style-type: none"> Check operation and adjust brake lever free play. | √ | √ | √ | √ | √ | √ |
| | | <ul style="list-style-type: none"> Replace brake shoes. | Whenever worn to the limit | | | | | |
| 8 | * Brake hoses | <ul style="list-style-type: none"> Check for cracks or damage. Check for correct routing and clamping. | | √ | √ | √ | √ | √ |
| | | <ul style="list-style-type: none"> Replace. | Every 4 years | | | | | |
| 9 | * Brake fluid | <ul style="list-style-type: none"> Change. | Every 2 years | | | | | |
| 10 | * Wheels | <ul style="list-style-type: none"> Check runout and for damage. | | √ | √ | √ | √ | |

Periodic maintenance and adjustment

| NO. | ITEM | CHECK OR MAINTENANCE JOB | ODOMETER READING (whichever comes first) | | | | | ANNUAL CHECK |
|-----|-------------------------------|--|--|---------------------------|---------------------------|-----------------------------|-----------------------------|--------------|
| | | | 1000 km or 1 month | 4000 km or 4 months | 8000 km or 8 months | 12000 km or 12 months | 16000 km or 16 months | |
| 11 | * Tires | <ul style="list-style-type: none"> • Check tread depth and for damage. • Replace if necessary. • Check air pressure. • Correct if necessary. | | √ | √ | √ | √ | √ |
| 12 | * Wheel bearings | <ul style="list-style-type: none"> • Check bearings for looseness or damage. | | √ | √ | √ | √ | |
| 13 | * Steering bearings | <ul style="list-style-type: none"> • Check bearing play and steering for roughness. | √ | √ | √ | √ | √ | |
| | | <ul style="list-style-type: none"> • Lubricate with lithium-soap-based grease. | Every 12000 km (7500 mi) | | | | | |
| 14 | * Chassis fasteners | <ul style="list-style-type: none"> • Make sure that all nuts, bolts and screws are properly tightened. | | √ | √ | √ | √ | √ |
| 15 | Front brake lever pivot shaft | <ul style="list-style-type: none"> • Lubricate with silicone grease. | | √ | √ | √ | √ | √ |
| 16 | Rear brake lever pivot shaft | <ul style="list-style-type: none"> • Lubricate with silicone grease. | | √ | √ | √ | √ | √ |
| 17 | * Unified brake system | <ul style="list-style-type: none"> • Check cable free play and adjust if necessary. | √ | √ | √ | √ | √ | √ |
| | | <ul style="list-style-type: none"> • Lubricate link pivot of brake pedal with lithium-soap-based grease. | √ | √ | √ | √ | √ | √ |
| 18 | Sidestand, center-stand | <ul style="list-style-type: none"> • Check operation. • Lubricate with lithium-soap-based grease. | | √ | √ | √ | √ | √ |
| 19 | * Sidestand switch | <ul style="list-style-type: none"> • Check operation. | √ | √ | √ | √ | √ | √ |

Periodic maintenance and adjustment

| NO. | ITEM | CHECK OR MAINTENANCE JOB | ODOMETER READING (whichever comes first) | | | | | ANNUAL CHECK |
|-----|---------------------------------|--|--|---------------------------|---------------------------|-----------------------------|-----------------------------|--------------|
| | | | 1000 km or 1 month | 4000 km or 4 months | 8000 km or 8 months | 12000 km or 12 months | 16000 km or 16 months | |
| 20 | * Front fork | • Check operation and for oil leakage. | | √ | √ | √ | √ | |
| 21 | * Shock absorber assembly | • Check operation and shock absorber for oil leakage. | | √ | √ | √ | √ | |
| 22 | Engine oil | • Change. • Check oil level and vehicle for oil leakage. | √ | √ | √ | √ | √ | |
| 23 | * Engine oil strainer | • Clean. | √ | | | | | √ |
| 24 | Final transmission oil | • Check vehicle for oil leakage. | √ | √ | √ | √ | √ | |
| | | • Change. | √ | Every 12000 km (7500 mi) | | | | |
| 25 | * V-belt | • Check for damage and wear. | | | √ | √ | √ | √ |
| | | • Replace. | Every 25000 km (15500 mi) | | | | | |
| 26 | * V-belt secondary sheave | • Lubricate. | Every 12000 km (7500 mi) | | | | | |
| 27 | * Front and rear brake switches | • Check operation. | √ | √ | √ | √ | √ | √ |
| 28 | Moving parts and cables | • Lubricate. | | √ | √ | √ | √ | √ |
| 29 | * Throttle grip | • Check operation. • Check throttle grip free play, and adjust if necessary. • Lubricate cable and grip housing. | | √ | √ | √ | √ | √ |
| 30 | * Lights, signals and switches | • Check operation. • Adjust headlight beam. | √ | √ | √ | √ | √ | √ |

Periodic maintenance and adjustment

EAUU1622

TIP

- Air filter
 - This model's air filter is equipped with a disposable oil-coated paper element, which must not be cleaned with compressed air to avoid damaging it.
 - The air filter element needs to be replaced more frequently when riding in unusually wet or dusty areas.
- V-belt case air filter
 - The air filter needs more frequent service if you are riding in unusually wet or dusty areas.
- V-belt
 - The V-belt should be checked at the initial 8000 km (5000 mi) and every 4000 km (2500 mi) thereafter. Replace the V-belt if any damage or wear is found. The V-belt needs to be replaced every 25000 km (16000 mi) even if there is no wear or damage.
- Hydraulic brake service
 - Regularly check and, if necessary, correct the brake fluid level. After disassembling the brake master cylinders and calipers, always change the brake fluid.
 - Every two years replace the internal components of the brake master cylinder and caliper, and change the brake fluid.
 - Replace the brake hose every four years and if cracked or damaged.
- Fuel system service
 - Use only unleaded gasoline. The use of leaded gasoline will cause severe damage to internal engine parts, such as the valves and piston rings, as well as to the exhaust system.
 - Replace the fuel filler cover every two years or if cracked or damaged.
 - Check the fuel filter if clogged or damaged every 12000 km (7500 mi).
- Battery service
 - Check the condition and service every 3 months.
 - Recharge the battery immediately if the voltage is less than 12.4 V.
 - If the battery tends to discharge, replace it immediately.

Periodic maintenance and adjustment

- If the vehicle will not be used for more than one month, remove the battery, fully charge it, and then place it in a cool, dry place.
-

Periodic maintenance and adjustment

Removing and installing panels

EAU18773

The panels shown need to be removed to perform some of the maintenance jobs described in this chapter. Refer to this section each time a panel needs to be removed and installed.

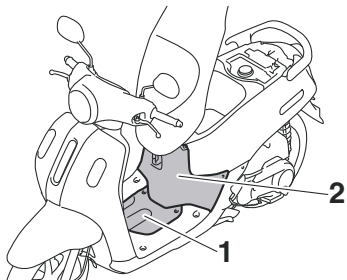

1. Panel A
2. Panel B

EAUN3522

Panel A

To remove the panel

Remove the screws, and then take the panel off.

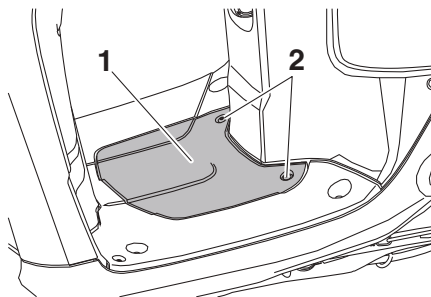

1. Panel A
2. Screw

To install the panel

Place the panel in the original position, and then install the screws.

Panel B

To remove the panel

1. Open the seat. (See page 7-15.)
2. Remove the screws, and then take the panel off.

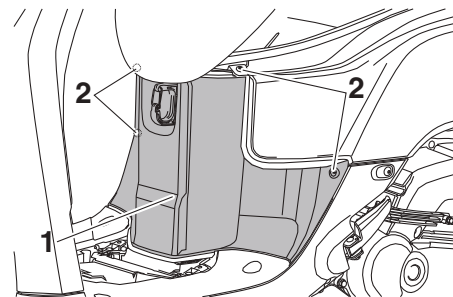

1. Panel B
2. Screw

To install the panel

1. Place the panel in the original position, and then install the screws.
2. Close the seat.

Periodic maintenance and adjustment

EAUT2077

Checking the spark plug

The spark plug is an important engine component, which is easy to check. Since heat and deposits will cause any spark plug to slowly erode, the spark plug should be removed and checked in accordance with the periodic maintenance and lubrication chart. In addition, the condition of the spark plug can reveal the condition of the engine.

To remove the spark plug

1. Remove panel B. (See page 10-8.)
2. Remove the spark plug cap.

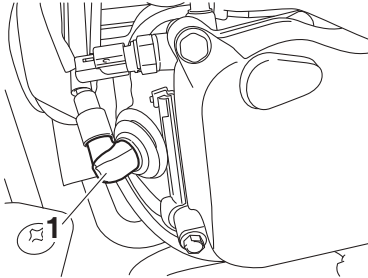

1. Spark plug cap

3. Remove the spark plug as shown, with a spark plug wrench available at a Yamaha dealer.

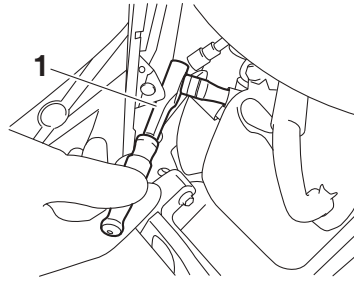

1. Spark plug wrench

To check the spark plug

1. Check that the porcelain insulator around the center electrode of the spark plug is a medium-to-light tan (the ideal color when the vehicle is ridden normally).

TIP

If the spark plug shows a distinctly different color, the engine could be operating improperly. Do not attempt to diagnose such problems yourself. Instead, have a Yamaha dealer check the vehicle.

2. Check the spark plug for electrode erosion and excessive carbon or other deposits, and replace it if necessary.

Specified spark plug:

NGK/CR6HSA

3. Measure the spark plug gap with a wire thickness gauge and, if necessary, adjust the gap to specification.

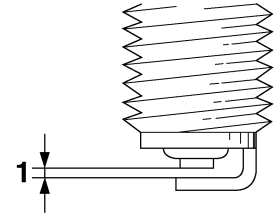

1. Spark plug gap

Spark plug gap:

0.6–0.7 mm (0.024–0.028 in)

Periodic maintenance and adjustment

To install the spark plug

1. Clean the surface of the spark plug gasket and its mating surface, and then wipe off any grime from the spark plug threads.
2. Install the spark plug with the spark plug wrench, and then tighten it to the specified torque.

Tightening torque:

Spark plug:
13 N·m (1.3 kgf·m, 9.6 lb·ft)

TIP

If a torque wrench is not available when installing a spark plug, a good estimate of the correct torque is 1/4–1/2 turn past finger tight. However, the spark plug should be tightened to the specified torque as soon as possible.

3. Install the spark plug cap.

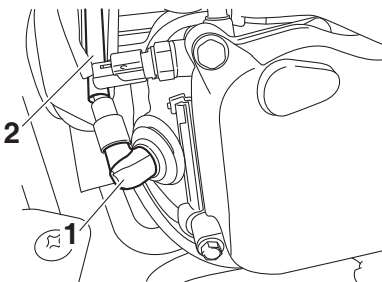

1. Spark plug cap
2. Spark plug lead
4. Install the panel B.

Engine oil and oil strainer

EAU66996

The engine oil level should be checked before each ride. In addition, the oil must be changed and the oil strainer cleaned at the intervals specified in the periodic maintenance and lubrication chart.

To check the engine oil level

1. Place the vehicle on the center-stand. A slight tilt to the side can result in a false reading.
2. Start the engine, warm it up for several minutes, and then turn it off.
3. Wait a few minutes until the oil settles, remove the engine oil filler cap, wipe the engine oil dipstick clean, insert it back into the oil filler hole (without screwing it in), and then remove it again to check the oil level. **WARNING! The muffler and muffler protector become very hot during use. To avoid possible burns, let the muffler and protector cool before removing the oil filler cap.** [EWA17810]

Periodic maintenance and adjustment

TIP

The engine oil should be between the tip of the dipstick and the maximum level mark.

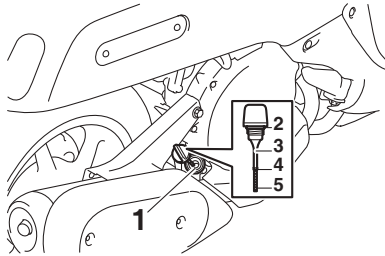

1. Oil filler hole
2. O-ring
3. Engine oil dipstick
4. Maximum level mark
5. Tip of the engine oil dipstick

4. If the engine oil is not between the tip of the dipstick and the maximum level mark, add sufficient oil of the recommended type to raise it to the correct level.
5. Insert the dipstick into the oil filler hole, and then tighten the oil filler cap.

To change the engine oil and clean the oil strainer

1. Start the engine, warm it up for several minutes, and then turn it off.
2. Place an oil pan under the engine to collect the used oil.
3. Remove the engine oil filler cap and engine oil drain bolts A and B to drain the oil from the crankcase.

NOTICE: When removing the engine oil drain bolt B, the O-ring, compression spring, and oil strainer will fall out. Take care not to lose these parts.

[ECAT1022]

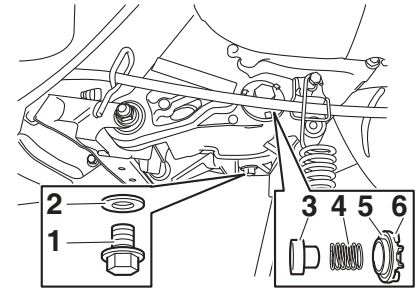

1. Engine oil drain bolt A
2. Gasket
3. Oil strainer
4. Compression spring
5. O-ring
6. Engine oil drain bolt B

4. Clean the engine oil strainer with solvent, and then check it for damage and replace it if necessary.
5. Install the engine oil strainer, compression spring, new O-ring and engine oil drain bolt B.

TIP

Make sure that the O-ring is properly seated.

Periodic maintenance and adjustment

6. Install engine oil drain bolt A and its new gasket, and then tighten both drain bolts to their specified torques.

Tightening torque:

Engine oil drain bolt A:
20 N·m (2.0 kgf·m, 15 lb·ft)
Engine oil drain bolt B:
20 N·m (2.0 kgf·m, 15 lb·ft)

7. Refill with the specified amount of the recommended engine oil, and then install and tighten the oil filler cap.

Recommended engine oil:

See page 12-1.

Oil quantity:

0.80 L (0.85 US qt, 0.70 Imp.qt)

8. Start the engine, and then let it idle for several minutes while checking it for oil leakage. If oil is leaking, immediately turn the engine off and check for the cause.
9. Turn the engine off, and then check the oil level and correct it if necessary.
10. Reset the oil change tripmeter and oil change indicator "OIL".

EAU85450

Why Yamalube

YAMALUBE oil is a Genuine YAMAHA Part born of the engineers' passion and belief that engine oil is an important liquid engine component. We form teams of specialists in the fields of mechanical engineering, chemistry, electronics and track testing, and have them develop the engine together with the oil it will use. Yamalube oils take full advantage of the base oil's qualities and blend in the ideal balance of additives to make sure the final oil clears our performance standards. Thus, Yamalube mineral, semisynthetic and synthetic oils have their own distinct characters and value. Yamaha's experience gained over many years of research and development into oil since the 1960's helps make Yamalube the best choice for your Yamaha engine.

YAMALUBE®

10

TIP

Be sure to wipe off spilled oil on any parts after the engine and exhaust system have cooled down.

ECA24060

NOTICE

Make sure that no foreign material enters the crankcase.

Periodic maintenance and adjustment

EAU67822

Final transmission oil

The final transmission case must be checked for oil leakage before each ride. If any leakage is found, have a Yamaha dealer check and repair your motorcycle. In addition, the final transmission oil must be changed as follows at the intervals specified in the periodic maintenance and lubrication chart.

1. Start the engine and warm up the final transmission oil by riding the motorcycle for several minutes.
2. Stop the engine and then place the motorcycle on the center-stand.
3. Place an oil pan under the final transmission case to collect the used oil.
4. Remove the final transmission oil filler cap and its O-ring from the final transmission case.

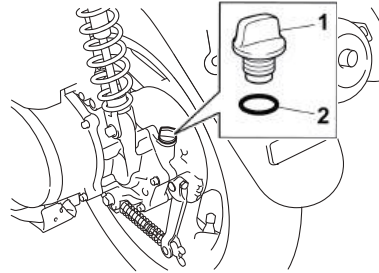

1. Final transmission oil filler cap
2. O-ring

5. Remove the final transmission oil drain bolt and its gasket to drain the oil from the final transmission case.

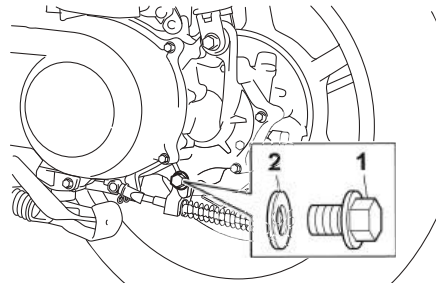

1. Final transmission oil drain bolt
2. Gasket

6. Install the final transmission oil drain bolt and its new gasket, and then tighten the bolt to the specified torque.

TIP

- Before installing the final transmission oil drain bolt and gasket, apply oil to them.
- Wipe off any excess oil afterwards.

Tightening torque:

Final transmission oil drain bolt:
20 N·m (2.0 kgf·m, 15 lb·ft)

7. Refill with the specified amount of the recommended final transmission oil. **WARNING! Make sure that no foreign material enters the final transmission case. Make sure that no oil gets on the tire or wheel.** [EWA11312]

Recommended final transmission oil:

See page 12-1.

Oil quantity:

0.10 L (0.11 US qt, 0.09 Imp.qt)

Periodic maintenance and adjustment

8. Install the final transmission oil filler cap and its new O-ring, and then tighten the oil filler cap.
9. Check the final transmission case for oil leakage. If oil is leaking, check for the cause.

Air filter and V-belt case air filter elements EAUN2380

The air filter element should be replaced and the V-belt case air filter element should be cleaned at the intervals specified in the periodic maintenance and lubrication chart. Service the air filter elements more frequently if you are riding in unusually wet or dusty areas. The air filter check hose and V-belt case air filter check hose must be frequently checked and cleaned if necessary.

Cleaning the air filter check hose

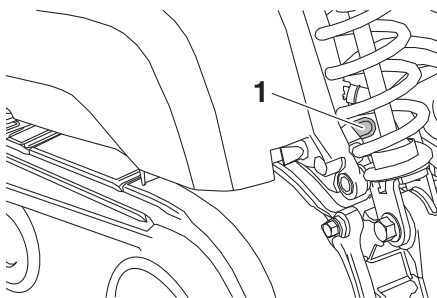

1. Air filter check hose

1. Check the hose on the rear side of the air filter case for accumulated dirt or water.
2. If dirt or water is visible, remove the hose from the clamp, clean it, and then install it.

TIP

If dirt or water was found in the check hose, be sure to check the air filter element for excessive dirt or damage and replace it if necessary.

Replacing the air filter element

1. Place the vehicle on the center-stand.
2. Remove the air filter case cover by removing the screws.

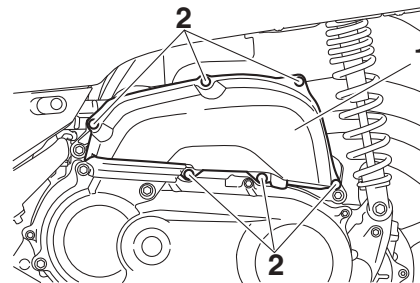

1. Air filter case cover
2. Screw

Periodic maintenance and adjustment

3. Pull the air filter element out.

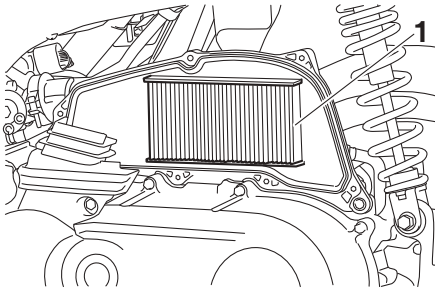

1. Air filter element

4. Insert a new air filter element into the air filter case. **NOTICE:** Make sure that the air filter element is properly seated in the air filter case. The engine should never be operated without the air filter element installed, otherwise the piston(s) and/or cylinder(s) may become excessively worn.

[ECA10482]

ECA21220

NOTICE

- The air filter element must be replaced at the intervals specified in the periodic maintenance chart.

- The air filter element should be replaced more frequently if you often ride in the rain or dusty areas.
- The air filter cannot be cleaned by blowing it with compressed air. It must be replaced.

5. Install the air filter case cover by installing the screws.

Cleaning the V-belt case check hose

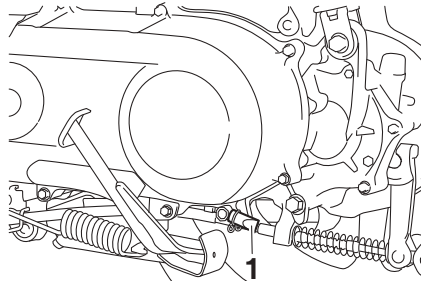

1. V-belt case check hose

1. Check the hose on the rear side of the V-belt case for accumulated dirt or water.
2. If dirt or water is visible, remove the hose from the clamp, clean it, and then install it.

TIP

If dirt or water was found in the check hose, be sure to check the V-belt case air filter element for excessive dirt or damage and clean or replace it if necessary.

Cleaning the V-belt case air filter element

1. Place the vehicle on the center-stand.
2. Remove the bolts, and then pull the V-belt case air filter element cover outward and away from the V-belt case.

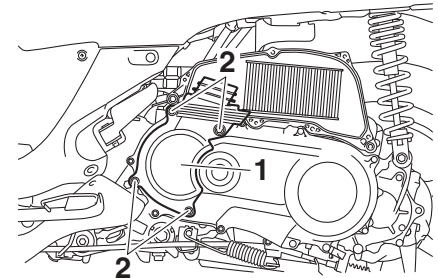

1. V-belt case air filter element cover
2. Bolt

Periodic maintenance and adjustment

3. Pull the V-belt case air filter element out, and then clean it with solvent. After cleaning, remove the remaining solvent by squeezing the element. **WARNING! Use only a dedicated parts cleaning solvent. To avoid the risk of fire or explosion, do not use gasoline or solvents with a low flash point.** [EWA10432] **NOTICE: To avoid damaging the air filter element, handle it gently and carefully, and do not twist it.** [ECA10522]

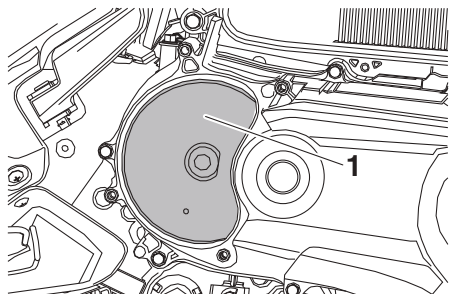

1. V-belt case air filter element

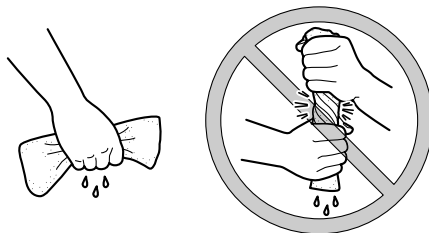

4. Apply oil of the recommended type to the entire surface of the sponge material, and then squeeze the excess oil out.

TIP

- The air filter element should be wet but not dripping.
- Check the air filter element for excessive dirt or damage and replace it if necessary.

Recommended oil:

Yamaha foam air filter oil or other quality foam air filter oil

5. Insert the element into the V-belt case.
6. Install the air filter element cover by installing the bolts.

EAU21386

Checking the throttle grip free play

Measure the throttle grip free play as shown.

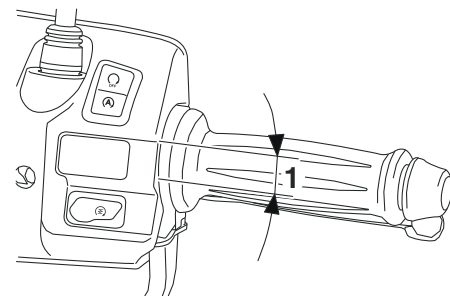

1. Throttle grip free play

Throttle grip free play:

3.0–7.0 mm (0.12–0.28 in)

Periodically check the throttle grip free play and, if necessary, have a Yamaha dealer adjust it.

EAU21403

EAU82721

Valve clearance

The valves are an important engine component, and since valve clearance changes with use, they must be checked and adjusted at the intervals specified in the periodic maintenance chart. Unadjusted valves can result in improper air-fuel mixture, engine noise, and eventually engine damage. To prevent this from occurring, have your Yamaha dealer check and adjust the valve clearance at regular intervals.

TIP

This service must be performed when the engine is cold.

Tires

Tires are the only contact between the vehicle and the road. Safety in all conditions of riding depends on a relatively small area of road contact. Therefore, it is essential to maintain the tires in good condition at all times and replace them at the appropriate time with the specified tires.

Tire air pressure

The tire air pressure should be checked and, if necessary, adjusted before each ride.

EWA10504

WARNING

Operation of this vehicle with improper tire pressure may cause severe injury or death from loss of control.

- The tire air pressure must be checked and adjusted on cold tires (i.e., when the temperature of the tires equals the ambient temperature).
- The tire air pressure must be adjusted in accordance with the riding speed and with the total

weight of rider, passenger, cargo, and accessories approved for this model.

Cold tire air pressure:

1 person:

Front:

150 kPa (1.50 kgf/cm², 22 psi)

Rear:

225 kPa (2.25 kgf/cm², 33 psi)

2 persons:

Front:

150 kPa (1.50 kgf/cm², 22 psi)

Rear:

225 kPa (2.25 kgf/cm², 33 psi)

Maximum load:

Vehicle:

158 kg (348 lb)

The vehicle's maximum load is the combined weight of the rider, passenger, cargo, and any accessories.

EWA10512

WARNING

Never overload your vehicle. Operation of an overloaded vehicle could cause an accident.

Periodic maintenance and adjustment

Tire inspection

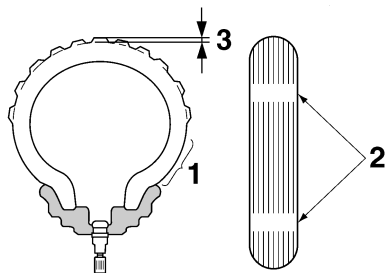

1. Tire sidewall
2. Tire wear indicator
3. Tire tread depth

The tires must be checked before each ride. If a tire tread shows crosswise lines (minimum tread depth), if the tire has a nail or glass fragments in it, or if the sidewall is cracked, contact a Yamaha dealer immediately and have the tire replaced.

Minimum tire tread depth (front and rear):
1.0 mm (0.04 in)

WARNING

EWA10583

- It is dangerous to ride with a worn-out tire. When a tire tread begins to show crosswise lines, have a Yamaha dealer replace the tire immediately.
- The replacement of all wheel and brake-related parts, including the tires, should be left to a Yamaha dealer, who has the necessary professional knowledge and experience to do so.
- Ride at moderate speeds after changing a tire since the tire surface must first be “broken in” for it to develop its optimal characteristics.

Tire information

This model is equipped with tubeless tires and tire air valves. Tires age, even if they have not been used or have only been used occasionally. Cracking of the tread and sidewall rubber, sometimes accompanied by carcass deformation, is an evidence of

ageing. Old and aged tires shall be checked by tire specialists to ascertain their suitability for further use.

EWA10462

WARNING

The front and rear tires should be of the same make and design, otherwise the handling characteristics of the vehicle may be different, which could lead to an accident.

After extensive tests, only the tires listed below have been approved for this model by Yamaha.

Front tire:

Size:

110/70-12 47L

Manufacturer/model:

DUNLOP/SCOOTSMART

Rear tire:

Size:

110/70-12 47L

Manufacturer/model:

DUNLOP/SCOOTSMART

Cast wheels

EAU21963

To maximize the performance, durability, and safe operation of your vehicle, note the following points regarding the specified wheels.

- The wheel rims should be checked for cracks, bends, warpage or other damage before each ride. If any damage is found, have a Yamaha dealer replace the wheel. Do not attempt even the smallest repair to the wheel. A deformed or cracked wheel must be replaced.
- The wheel should be balanced whenever either the tire or wheel has been changed or replaced. An unbalanced wheel can result in poor performance, adverse handling characteristics, and a shortened tire life.

Checking the front brake lever free play

EAU49351

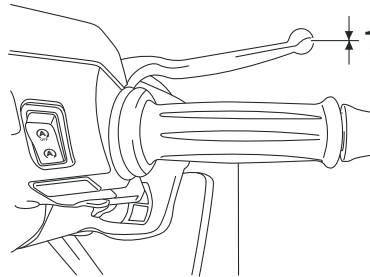

1. No brake lever free play

There should be no free play at the brake lever end. If there is free play, have a Yamaha dealer inspect the brake system.

EWA14212

WARNING

A soft or spongy feeling in the brake lever can indicate the presence of air in the hydraulic system. If there is air in the hydraulic system, have a Yamaha dealer bleed the system before operating the vehicle. Air in the hydraulic system will diminish the

braking performance, which may result in loss of control and an accident.

Periodic maintenance and adjustment

Adjusting the rear brake lever free play

EAU22172

Measure the rear brake lever free play as shown.

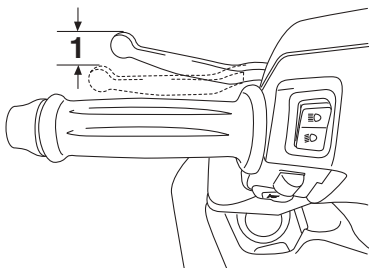

1. Rear brake lever free play

Rear brake lever free play:
10.0–20.0 mm (0.39–0.79 in)

Periodically check the brake lever free play and, if necessary, adjust it as follows.

To increase the brake lever free play, turn the adjusting nut at the brake shoe plate in direction (a). To decrease the brake lever free play, turn the adjusting nut in direction (b).

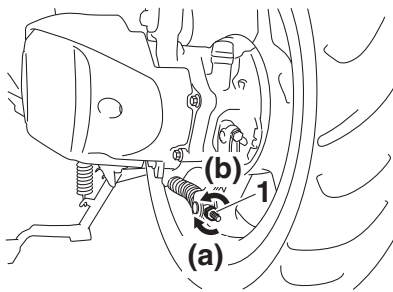

1. Rear brake lever free play adjusting nut

WARNING

EWA10651

If proper adjustment cannot be obtained as described, have a Yamaha dealer make this adjustment.

Checking the front brake pads and rear brake shoes

EAU22382

The front brake pads and the rear brake shoes must be checked for wear at the intervals specified in the periodic maintenance and lubrication chart.

Front brake pads

EAU22434

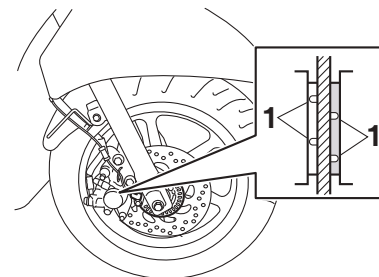

1. Brake pad wear indicator groove

Each front brake pad is provided with wear indicator grooves, which allow you to check the brake pad wear without having to disassemble the brake. To check the brake pad wear, check the wear indicator grooves. If a brake pad has worn to the point that the wear

Periodic maintenance and adjustment

indicator grooves have almost disappeared, have a Yamaha dealer replace the brake pads as a set.

Rear brake shoes

EAU22541

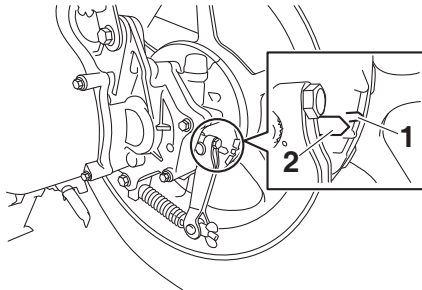

1. Brake shoe wear indicator
2. Brake shoe wear limit line

The rear brake is provided with a wear indicator, which allows you to check the brake shoe wear without having to disassemble the brake. To check the brake shoe wear, check the position of the wear indicator while applying the brake. If a brake shoe has worn to the point that the wear indicator reaches the wear limit line, have a Yamaha dealer replace the brake shoes as a set.

Checking the brake fluid level

EAU37004

Before riding, check that the brake fluid is above the minimum level mark. Check the brake fluid level with the top of the reservoir level. Replenish the brake fluid if necessary.

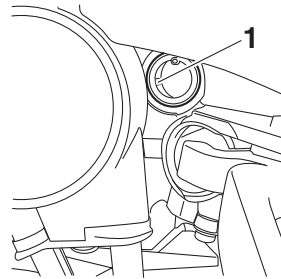

1. Minimum level mark

Specified brake fluid:
DOT 3 or DOT 4

EWA15981

! WARNING

Improper maintenance can result in loss of braking ability. Observe these precautions:

- Insufficient brake fluid may allow air to enter the brake system, reducing braking performance.
- Clean the filler cap before removing. Use only DOT 3 or DOT 4 brake fluid from a sealed container.
- Use only the specified brake fluid; otherwise, the rubber seals may deteriorate, causing leakage.
- Refill with the same type of brake fluid. Adding a brake fluid other than DOT 3 or DOT 4 may result in a harmful chemical reaction.
- Be careful that water does not enter the brake fluid reservoir when refilling. Water will significantly lower the boiling point of the fluid and may result in vapor lock.

ECA17641

NOTICE

Brake fluid may damage painted surfaces or plastic parts. Always clean up spilled fluid immediately.

Periodic maintenance and adjustment

As the brake pads wear, it is normal for the brake fluid level to gradually go down. A low brake fluid level may indicate worn brake pads and/or brake system leakage; therefore, be sure to check the brake pads for wear and the brake system for leakage. If the brake fluid level goes down suddenly, have a Yamaha dealer check the cause before further riding.

EAU22734

Changing the brake fluid

Have a Yamaha dealer change the brake fluid every 2 years. In addition, have the seals of the master cylinders and brake calipers, as well as the brake hoses replaced at the intervals listed below or sooner if they are damaged or leaking.

- Brake seals: every 2 years
- Brake hoses: every 4 years

EAU0311

Checking the V-belt

The V-belt must be checked and replaced by a Yamaha dealer at the intervals specified in the periodic maintenance and lubrication chart.

Checking and lubricating the cables

EAU23098

The operation of all control cables and the condition of the cables should be checked before each ride, and the cables and cable ends should be lubricated if necessary. If a cable is damaged or does not move smoothly, have a Yamaha dealer check or replace it. **WARNING! Damage to the outer housing of cables may result in internal rusting and cause interference with cable movement. Replace damaged cables as soon as possible to prevent unsafe conditions.** [EWA10712]

Recommended lubricant:

Yamaha cable lubricant or other suitable cable lubricant

Checking and lubricating the throttle grip and cable

EAU49921

The operation of the throttle grip should be checked before each ride. In addition, the cable should be lubricated by a Yamaha dealer at the intervals specified in the periodic maintenance chart.

Lubricating the front and rear brake levers

EAU23173

Front brake lever

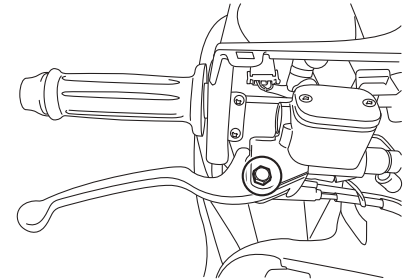

Rear brake lever

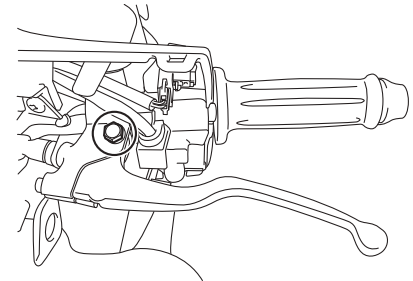

The pivoting points of the front and rear brake levers must be lubricated at the intervals specified in the periodic maintenance and lubrication chart.

Periodic maintenance and adjustment

Recommended lubricant:

Silicone grease

Checking and lubricating the centerstand and sidestand

EAU23215

Recommended lubricant:

Lithium-soap-based grease

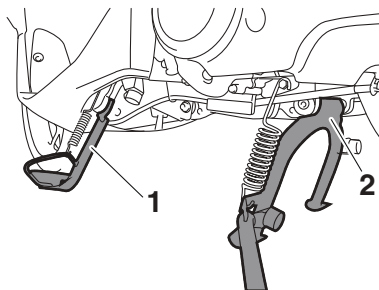

1. Sidestand
2. Centerstand

The operation of the centerstand and sidestand should be checked before each ride, and the pivots and metal-to-metal contact surfaces should be lubricated if necessary.

EWA10742

WARNING

If the centerstand or sidestand does not move up and down smoothly, have a Yamaha dealer check or repair it. Otherwise, the centerstand or sidestand could contact the ground and distract the operator, resulting in a possible loss of control.

EAU23273

Checking the front fork

The condition and operation of the front fork must be checked as follows at the intervals specified in the periodic maintenance and lubrication chart.

To check the condition

Check the inner tubes for scratches, damage and excessive oil leakage.

To check the operation

1. Place the vehicle on a level surface and hold it in an upright position. **WARNING! To avoid injury, securely support the vehicle so there is no danger of it falling over.** [EWA10752]
2. While applying the front brake, push down hard on the handlebars several times to check if the front fork compresses and rebounds smoothly.

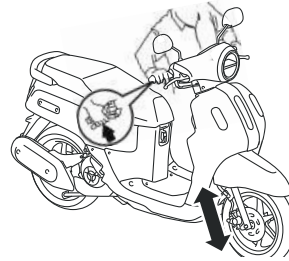

ECA10591

NOTICE

If any damage is found or the front fork does not operate smoothly, have a Yamaha dealer check or repair it.

EAU45512

Checking the steering

Worn or loose steering bearings may cause danger. Therefore, the operation of the steering must be checked as follows at the intervals specified in the periodic maintenance and lubrication chart.

1. Place the vehicle on the center-stand. **WARNING! To avoid injury, securely support the vehicle so there is no danger of it falling over.** [EWA10752]
2. Hold the lower ends of the front fork legs and try to move them forward and backward. If any free play can be felt, have a Yamaha dealer check or repair the steering.

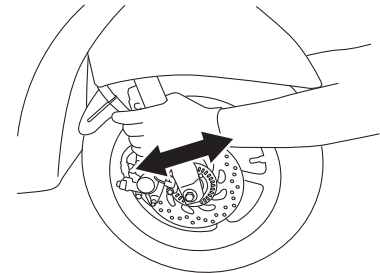

Periodic maintenance and adjustment

Checking the wheel bearings

EAU23292

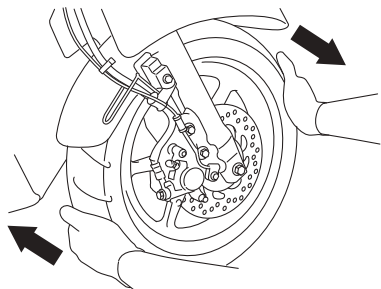

The front and rear wheel bearings must be checked at the intervals specified in the periodic maintenance and lubrication chart. If there is play in the wheel hub or if the wheel does not turn smoothly, have a Yamaha dealer check the wheel bearings.

Battery

EAUN3531

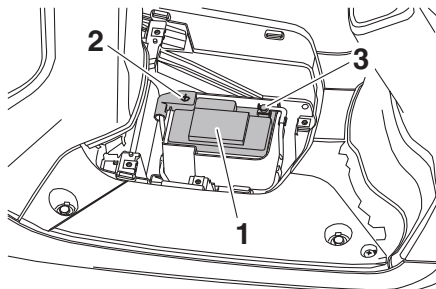

1. Battery
2. Positive battery lead (red)
3. Negative battery lead (black)

The battery is located under the footboard.

This model is equipped with a VRLA (Valve Regulated Lead Acid) battery. There is no need to check the electrolyte or to add distilled water. However, the battery lead connections need to be checked and, if necessary, tightened.

EWA10761



WARNING

- **Electrolyte is poisonous and dangerous since it contains sulfuric acid, which causes severe**

burns. Avoid any contact with skin, eyes or clothing and always shield your eyes when working near batteries. In case of contact, administer the following **FIRST AID**.

- **EXTERNAL:** Flush with plenty of water.
- **INTERNAL:** Drink large quantities of water or milk and immediately call a physician.
- **EYES:** Flush with water for 15 minutes and seek prompt medical attention.
- **Batteries produce explosive hydrogen gas. Therefore, keep sparks, flames, cigarettes, etc., away from the battery and provide sufficient ventilation when charging it in an enclosed space.**
- **KEEP THIS AND ALL BATTERIES OUT OF THE REACH OF CHILDREN.**

To access the battery

1. Remove the panel A. (See page 10-8.)

2. Remove the battery cover by pulling it upward.

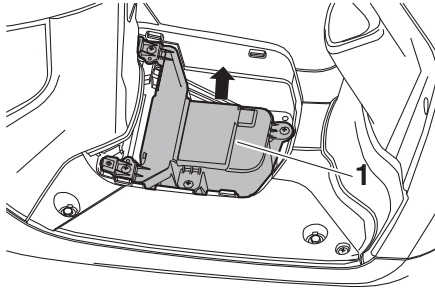

1. Battery cover

To charge the battery

Have a Yamaha dealer charge the battery as soon as possible if it seems to have discharged. Keep in mind that the battery tends to discharge more quickly if the vehicle is equipped with optional electrical accessories.

ECA16522

NOTICE

To charge a VRLA (Valve Regulated Lead Acid) battery, a special (constant-voltage) battery charger is required. Using a conventional battery charger will damage the battery.

To store the battery

1. If the vehicle will not be used for more than one month, remove the battery, fully charge it, and then place it in a cool, dry place.
NOTICE: When removing the battery, be sure to turn the main switch off, then disconnect the negative lead before disconnecting the positive lead. [ECA16304]
2. If the battery will be stored for more than two months, check it at least once a month and fully charge it if necessary.
3. Fully charge the battery before installation. **NOTICE: When installing the battery, be sure to turn the main switch off, then connect the positive lead before connecting the negative lead.** [ECA16842]
4. After installation, make sure that the battery leads are properly connected to the battery terminals.

NOTICE

Always keep the battery charged. Storing a discharged battery can cause permanent battery damage.

Periodic maintenance and adjustment

EAUN3540

Replacing the fuses

The fuse box, which contains the fuses for the individual circuits, is located behind panel B. (See page 10-8.)

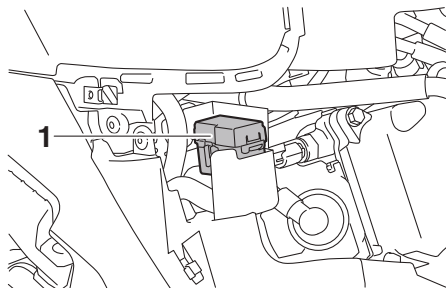

1. Fuse box

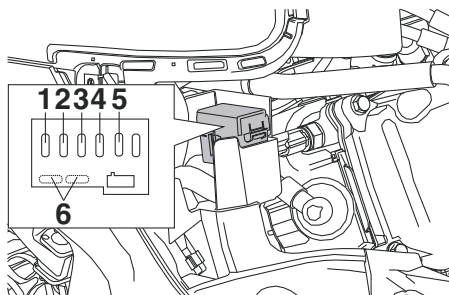

1. Main fuse
2. Signaling system fuse 1
3. Signaling system fuse 2
4. Backup fuse
5. Auxiliary DC connector fuse
6. Spare fuse

If a fuse is blown, replace it as follows.

1. Turn off the electrical circuit in question, and then turn off the main switch.
2. Remove panel B. (See page 10-8.)
3. Remove the blown fuse, and then install a new fuse of the specified amperage. **WARNING! Do not use a fuse of a higher amperage rating than recommended to avoid causing extensive damage to the electrical system and possibly a fire.** [EWA15132]

Specified fuses:

- Main fuse:
20.0 A
- Signaling system fuse 1:
7.5 A
- Signaling system fuse 2:
7.5 A
- Auxiliary DC connector fuse:
2.0 A
- Backup fuse:
7.5 A

4. Turn the main switch on, and then turn on the electrical circuit in question to check if the device operates.

TIP

If the fuse immediately blows again, have a Yamaha dealer check the electrical system.

5. Install panel B by installing the screws.

Periodic maintenance and adjustment

Headlight

EAU62851

This model is equipped with an LED-type headlight.

If a headlight does not come on, have a Yamaha dealer check its electrical circuit.

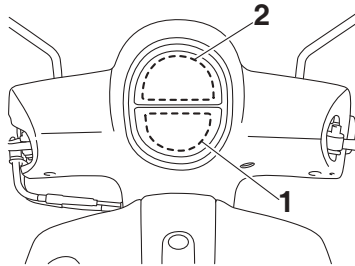

1. Headlight (high beam)
2. Headlight (low beam)

ECA16581

NOTICE

Do not affix any type of tinted film or stickers to the headlight lens.

Auxiliary light

EAU44941

This model is equipped with an LED-type auxiliary light.

If the auxiliary light does not come on, have a Yamaha dealer check it.

Front/rear turn signal light and tail/brake light

EAUE1991

If a front/rear turn signal light or a tail/brake light does not come on, have a Yamaha dealer check its electrical circuit or replace the bulb.

Periodic maintenance and adjustment

Troubleshooting

EAU60701

Although Yamaha vehicles receive a thorough inspection before shipment from the factory, trouble may occur during operation. Any problem in the fuel, compression, or ignition systems, for example, can cause poor starting and loss of power.

The following troubleshooting charts represent quick and easy procedures for checking these vital systems yourself. However, should your vehicle require any repair, take it to a Yamaha dealer, whose skilled technicians have the necessary tools, experience, and know-how to service the vehicle properly.

Use only genuine Yamaha replacement parts. Imitation parts may look like Yamaha parts, but they are often inferior, have a shorter service life and can lead to expensive repair bills.

EWA15142



WARNING

When checking the fuel system, do not smoke, and make sure there are no open flames or sparks in the area, including pilot lights from water

heaters or furnaces. Gasoline or gasoline vapors can ignite or explode, causing severe injury or property damage.

Smart key system troubleshooting

EAU76553

Please check the following items when the smart key system does not work.

- Is the smart key turned on? (See page 4-3.)
- Is the smart key battery discharged? (See page 4-4.)
- Is the smart key battery installed correctly? (See page 4-4.)
- Is the smart key being used in a location with strong radio waves or other electromagnetic noise? (See page 4-1.)
- Are you using the smart key that is registered to the vehicle?
- Is the vehicle battery discharged? When the vehicle battery is discharged, the smart key system will not operate. Please have the vehicle battery charged or replaced. (See page 10-26.)

If the smart key system does not work after checking the above items, have a Yamaha dealer check the smart key system.

TIP

See Emergency mode on page 10-33 for information on starting the engine without the smart key.

EAU76844

Stop and Start System troubleshooting

If a problem occurs, check the following before taking the vehicle to a Yamaha dealer.

The Stop and Start System indicator light does not come on.

1. Is the main switch turned on?
2. Is the Stop and Start System switch set to “”?
3. Was the engine warmed up sufficiently after starting?
4. After the engine was warmed up, was the engine left idling for a certain period of time?
5. Did the vehicle travel at a speed of 10 km/h or higher?

Periodic maintenance and adjustment

Even if the preceding conditions are met, the Stop and Start System may not activate in order to preserve battery power. In this case, continue to drive the vehicle.

In addition, the Stop and Start System indicator light does not come on if the malfunction indicator light (MIL)/engine trouble warning light is on.

If the Stop and Start System indicator light still does not come on after you checked the preceding conditions, have a Yamaha dealer check the vehicle as soon as possible.

The Stop and Start System indicator light comes on, but the engine does not stop automatically.

1. Was the vehicle stopped completely?

The engine may not stop automatically until the vehicle is stopped for a certain period of time. Try bringing the vehicle to a complete stop.

2. Is the throttle grip turned?

The engine does not stop automatically if the throttle grip is not in the fully closed position.

Turn the throttle grip to the fully closed position.

If the engine still does not stop automatically after you checked the preceding conditions, have a Yamaha dealer check the vehicle as soon as possible.

After the engine was stopped by the Stop and Start System, the engine does not restart even if the throttle grip is turned.

1. Is the Stop and Start System switch set to “”?

If the Stop and Start System switch is set to “” while the Stop and Start System is activated, the Stop and Start System will be turned off.

2. Was the sidestand operated?

When the sidestand is lowered, the Stop and Start System is deactivated.

3. Was the engine left stopped by the Stop and Start System for a long period of time?

If the engine is left stopped by the Stop and Start System for a long period of time, the battery could become discharged.

If the engine still does not restart after you checked the preceding conditions, have a Yamaha dealer check the vehicle as soon as possible.

Periodic maintenance and adjustment

EAU86350

Troubleshooting chart

1. Fuel

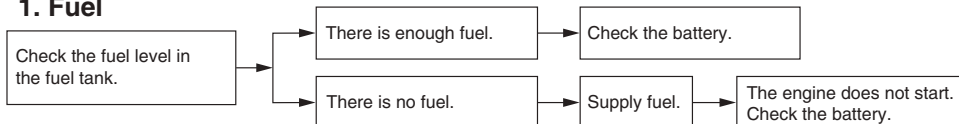

2. Battery

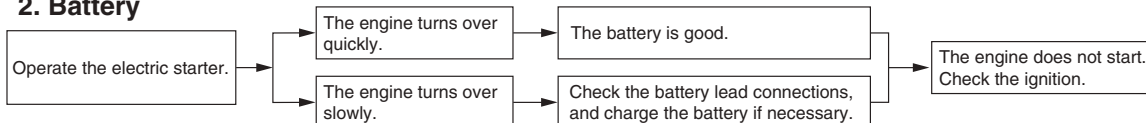

3. Ignition

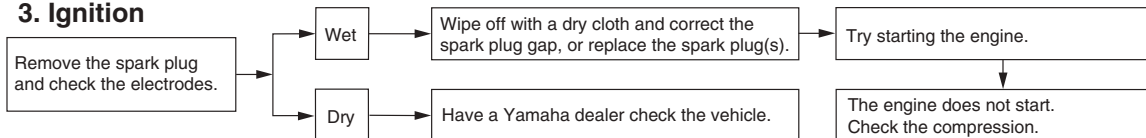

4. Compression

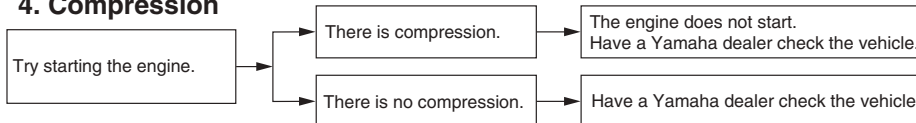

Periodic maintenance and adjustment

Emergency mode (LCF125-F)

EAU76564

When the smart key is lost or damaged, or its battery has discharged, the vehicle can still be turned on and the engine started. You will need the smart key system identification number.

To operate the vehicle in emergency mode

1. Stop the vehicle in a safe place and confirm the main switch is set to either “” or “OFF”.
2. Push the main switch knob for 5 seconds until the smart key system indicator light flashes once, then release it. Repeat two more times. The smart key system indicator light will come on for three seconds to indicate the transition to emergency mode.

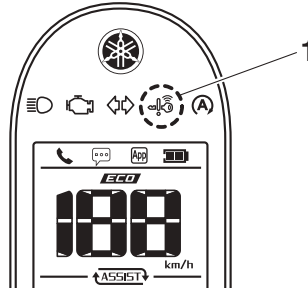

1. Smart key system indicator light “”

3. After the smart key system indicator light goes off, input the identification number as follows.

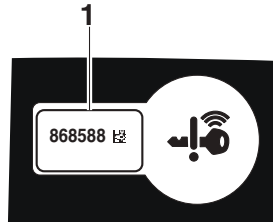

1. Identification number card

4. Inputting the identification number is done by counting the number of flashes of the smart key system indicator light.

For example, if the identification number is 123456:

Push and hold the knob.



The smart key system indicator light will start to flash.

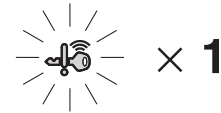

Release the knob after the smart key system indicator light flashes once.



The first digit of the identification number has been set as “1”.



Push and hold the knob again.



Periodic maintenance and adjustment

Release the knob after the smart key system indicator light flashes twice.



The second digit has been set as “2”.



Repeat the above procedure until all digits of the identification number have been set. The smart key system indicator light will flash for 10 seconds if the correct identification number was entered.

TIP

When one of the following situations applies, emergency mode will be terminated and the smart key system indicator light will flash quickly for 3 seconds. In this case, start over again from step 2.

- When there are no knob operations for 10 seconds during the identification number input process.
- When the smart key system indicator light is allowed to flash nine or more times.

- The identification number is not entered correctly.
-

5. While the smart key system indicator light is on, push the knob once more to complete emergency mode access. The smart key indicator light will go off and then come back on for approximately 4 seconds.
6. While the smart key system indicator light is on, turn the main switch to “ON”. The vehicle can now be operated normally.

Matte color caution

EAU37834

EAU0990

NOTICE

Some models are equipped with matte colored finished parts. Be sure to consult a Yamaha dealer for advice on what products to use before cleaning the vehicle. Using a brush, harsh chemical products or cleaning compounds when cleaning these parts will scratch or damage their surface. Wax also should not be applied to any matte colored finished parts.

ECA15193

Care

Frequent, thorough cleaning of the vehicle will not only enhance its appearance but also will improve its general performance and extend the useful life of many components. Washing, cleaning, and polishing will also give you a chance to inspect the condition of the vehicle more frequently. Be sure to wash the vehicle after riding in the rain or near the sea, because salt is corrosive to metals.

TIP

- Genuine Yamaha care and maintenance products are sold under the YAMALUBE brand in many markets worldwide.
- See your Yamaha dealer for additional cleaning tips.

ECA26280

NOTICE

Improper cleaning can cause cosmetic and mechanical damage. Do not use:

- high-pressure washers or steam-jet cleaners. Excessive water pressure may cause wa-

ter seepage and deterioration of wheel bearings, brakes, transmission seals and electrical devices. Avoid high-pressure detergent applications such as those available in coin-operated car washers.

- harsh chemicals, including strong acidic wheel cleaners, especially on spoke or magnesium wheels.
- harsh chemicals, abrasive cleaning compounds, or wax on matte-finished parts. Brushes can scratch and damage the matte-finish, use soft sponge or towel only.
- towels, sponges, or brushes contaminated with abrasive cleaning products or strong chemicals such as, solvents, gasoline, rust removers, brake fluid, or antifreeze, etc.

Before washing

1. Park the vehicle out of direct sunlight and allow it to cool. This will help avoid water spots.

Motorcycle care and storage

2. Make sure all caps, covers, electrical couplers and connectors are tightly installed.
3. Cover the muffler end with a plastic bag and a strong rubber band.
4. Pre-soak stubborn stains like insects or bird droppings with a wet towel for a few minutes.
5. Remove road grime and oil stains with a quality degreasing agent and a plastic-bristle brush or sponge. **NOTICE: Do not use degreasing agent on areas requiring lubrication such as seals, gaskets, and wheel axles. Follow product instructions.**

[ECA26290]

Washing

1. Rinse off any degreaser and spray down the vehicle with a garden hose. Use only enough pressure to do the job. Avoid spraying water directly into the muffler, instrument panel, air inlet, or other inner areas such as underseat storage compartments.

2. Wash the vehicle with a quality automotive-type detergent mixed with cool water and a soft, clean towel or sponge. Use an old toothbrush or plastic-bristle brush for hard-to-reach places. **NOTICE: Use cold water if the vehicle has been exposed to salt. Warm water will increase salt's corrosive properties.** [ECA26301]
3. For windshield-equipped vehicles: Clean the windshield with a soft towel or sponge dampened with water and a pH neutral detergent. If necessary, use a high-quality windshield cleaner or polish for motorcycles. **NOTICE: Never use any strong chemicals to clean the windshield. Additionally, some cleaning compounds for plastic may scratch the windshield, so be sure to test all cleaning products before general application.** [ECA26310]
4. Rinse off thoroughly with clean water. Be sure to remove all detergent residues, as they can be harmful to plastic parts.

After washing

1. Dry the vehicle with a chamois or absorbent towel, preferably microfiber terrycloth.
2. For drive chain-equipped models: Dry and then lubricate the drive chain to prevent rust.
3. Use a chrome polish to shine chrome, aluminum, and stainless steel parts. Often the thermally induced discoloring of stainless steel exhaust systems can be removed through polishing.
4. Apply a corrosion protection spray on all metal parts including chrome or nickel-plated surfaces. **WARNING! Do not apply silicone or oil spray to seats, hand grips, rubber foot pegs or tire treads. Otherwise these parts will become slippery, which could cause loss of control. Thoroughly clean the surfaces of these parts before operating the vehicle.** [EWA20651]
5. Treat rubber, vinyl, and unpainted plastic parts with a suitable care product.

6. Touch up minor paint damage caused by stones, etc.
7. Wax all painted surfaces using a non-abrasive wax or use a detail spray for motorcycles.
8. When finished cleaning, start the engine and let it idle for several minutes to help dry any remaining moisture.
9. If the headlight lens has fogged up, start the engine and turn on the headlight to help remove the moisture.
10. Let the vehicle dry completely before storing or covering it.

ECA26320

NOTICE

- Do not apply wax to rubber or unpainted plastic parts.
- Do not use abrasive polishing compounds as they will wear away the paint.
- Apply sprays and wax sparingly. Wipe off excess afterwards.

EWA20660



WARNING

Contaminants left on the brakes or tires can cause loss of control.

- **Make sure there is no lubricant or wax on the brakes or tires.**
- **If necessary, wash the tires with warm water and a mild detergent.**
- **If necessary, clean the brake discs and pads with brake cleaner or acetone.**
- **Before riding at higher speeds, test the vehicle's braking performance and cornering behavior.**

Storage

Always store the vehicle in a cool, dry place. If necessary, protect it against dust with a porous cover. Be sure the engine and the exhaust system are cool before covering the vehicle. If the vehicle often sits for weeks at a time between uses, the use of a quality fuel stabilizer is recommended after each fill-up.

ECA21170

NOTICE

- **Storing the vehicle in a poorly ventilated room or covering it with a tarp, while it is still wet, will allow water and humidity to seep in and cause rust.**
- **To prevent corrosion, avoid damp cellars, stables (because of the presence of ammonia) and areas where strong chemicals are stored.**

Long term storage

Before storing the vehicle long term (60 days or more):

Motorcycle care and storage

1. Make all necessary repairs and perform any outstanding maintenance.
2. Follow all instructions in the Care section of this chapter.
3. Fill up the fuel tank, adding fuel stabilizer according to product instructions. Run the engine for 5 minutes to distribute treated fuel through the fuel system.
4. For vehicles equipped with a fuel cock: Turn the fuel cock lever to the off position.
5. For vehicles with a carburetor: To prevent fuel deposits from building up, drain the fuel in the carburetor float chamber into a clean container. Retighten the drain bolt and pour the fuel back into the fuel tank.
6. Use a quality engine fogging oil according to product instructions to protect internal engine components from corrosion. If engine fogging oil is not available, perform the following steps for each cylinder:
 - a. Remove the spark plug cap and spark plug.
 - b. Pour a teaspoonful of engine oil into the spark plug bore.
 - c. Install the spark plug cap onto the spark plug, and then place the spark plug on the cylinder head so that the electrodes are grounded. (This will limit sparking during the next step.)
 - d. Turn the engine over several times with the starter. (This will coat the cylinder wall with oil.)
WARNING! To prevent damage or injury from sparking, make sure to ground the spark plug electrodes while turning the engine over.
[EWA10952]
 - e. Remove the spark plug cap from the spark plug, and then install the spark plug and the spark plug cap.
7. Lubricate all control cables, pivots, levers and pedals, as well as the sidestand and centerstand (if equipped).
8. Check and correct the tire air pressure, and then lift the vehicle so that all wheels are off the ground. Otherwise, turn the wheels a little once a month in order to prevent the tires from becoming degraded in one spot.
9. Cover the muffler outlet with a plastic bag to prevent moisture from entering it.
10. Remove the battery and fully charge it, or attach a maintenance charger to keep the battery optimally charged. **NOTICE: Confirm that the battery and its charger are compatible. Do not charge a VRLA battery with a conventional charger.**[ECA26330]

TIP

- If the battery will be removed, charge it once a month and store it in a temperate location between 0-30 °C (32-90 °F).
 - See page 10-26 for more information on charging and storing the battery.
-

Dimensions:

- Overall length:
1820 mm (71.7 in)
- Overall width:
685 mm (27.0 in)
- Overall height:
1125 mm (44.3 in)
- Seat height:
750 mm (29.5 in)
- Wheelbase:
1280 mm (50.4 in)
- Ground clearance:
135 mm (5.31 in)
- Minimum turning radius:
1.9 m (6.23 ft)

Weight:

- Curb weight:
96 kg (212 lb) (LCF125-C)
96 kg (213 lb) (LCF125-F)

Engine:

- Combustion cycle:
4-stroke
- Cooling system:
Air cooled
- Valve train:
SOHC
- Number of cylinders:
Single cylinder
- Displacement:
125 cm³
- Bore × stroke:
52.4 × 57.9 mm (2.06 × 2.28 in)

Starting system:

- Electric starter (LCF125-F)
- Electric starter and kickstarter (LCF125-C)

Engine oil:

Recommended brand:



SAE viscosity grades:

10W-40

Recommended engine oil grade:

API service SG type or higher, JASO standard MA or MB

Engine oil quantity:

Oil change:
0.80 L (0.85 US qt, 0.70 Imp.qt)

Final transmission oil:

Type:

Motor oil SAE 10W-40 type SG or higher

Quantity:

0.10 L (0.11 US qt, 0.09 Imp.qt)

Fuel:

Recommended fuel:

Unleaded gasoline (E10 to E20 only)

Octane number (RON):

90

Fuel tank capacity:

5.1 L (1.3 US gal, 1.1 Imp.gal)

Fuel reserve amount:

0.2 L (0.07 US gal, 0.06 Imp.gal)

Fuel injection:

Throttle body:

ID mark:
B8A1_10

Front tire:

Type:

Tubeless

Size:

110/70-12 47L

Manufacturer/model:

DUNLOP/SCOOTSMART

Rear tire:

Type:

Tubeless

Size:

110/70-12 47L

Manufacturer/model:

DUNLOP/SCOOTSMART

Loading:

Maximum load:

158 kg (348 lb)

(Total weight of rider, passenger, cargo and accessories)

Unified brake system:

Operation:

Activated by rear brake

Front brake:

Type:

Hydraulic single disc brake

Rear brake:

Type:

Mechanical leading trailing drum brake

Specifications

Front suspension:

Type:

Telescopic fork

Rear suspension:

Type:

Unit swing

Electrical system:

System voltage:

12 V

Battery:

Model:

YTZ6V

Voltage, capacity:

12 V, 5.0 Ah (10 HR)

Bulb wattage:

Headlight:

LED

Brake/tail light:

18.0 W/5.0 W

Front turn signal light:

10.0 W

Rear turn signal light:

10.0 W

Auxiliary light:

LED

Identification numbers

EAU26366

Record the vehicle identification number and the engine serial number in the spaces provided below for assistance when ordering spare parts from a Yamaha dealer or for reference in case the vehicle is stolen.

VEHICLE IDENTIFICATION NUMBER:

ENGINE SERIAL NUMBER:

Vehicle identification number

EAU26411

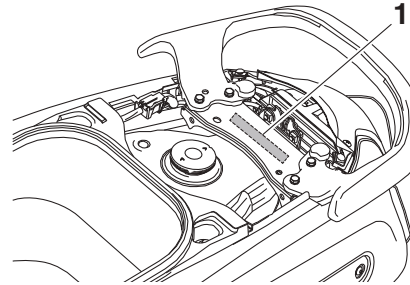

1. Vehicle identification number

The vehicle identification number is stamped into the frame.

TIP _____
The vehicle identification number is used to identify your vehicle and may be used to register it with the licensing authority in your area.

Engine serial number

EAU26442

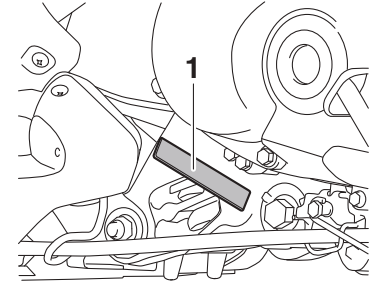

1. Engine serial number

The engine serial number is stamped into the crankcase.

Consumer information

EAU85400

Vehicle data recording

This model's ECU stores certain vehicle data to assist in the diagnosis of malfunctions and for research, statistical analysis and development purposes.

Although the sensors and recorded data will vary by model, the main data points are:

- Vehicle status and engine performance data
- Fuel-injection and emission-related data

This data will be uploaded only when a special Yamaha diagnostic tool is attached to the vehicle, such as when maintenance checks or service procedures are performed.

Yamaha will not disclose this data to a third party except in the following cases. In addition, Yamaha may provide vehicle data to a contractor in order to outsource services related to the handling of vehicle data. Even in this case, Yamaha will require the contractor to

properly handle the vehicle data we provided and Yamaha will appropriately manage the data.

- With the consent of the vehicle owner
- Where obligated by law
- For use by Yamaha in litigation
- When the data is not related to an individual vehicle nor owner

| | | | | |
|----------|--|----------|--|--|
| A | Acceleration and deceleration..... 9-3 | F | Final transmission oil..... 10-13 | Luggage hook..... 7-18 |
| | Activating the Stop and Start System 6-1 | | Front brake lever free play, checking 10-19 | M |
| | Air filter and V-belt case air filter elements 10-14 | | Front fork, checking 10-25 | Main switch..... 7-1 |
| | Auxiliary light 10-29 | | Front/rear turn signal light and tail/brake light 10-29 | Main switch/steering lock..... 7-4 |
| B | | | Fuel 7-13 | Maintenance and lubrication, periodic..... 10-3 |
| | Battery 10-26 | | Fuel consumption, tips for reducing 9-4 | Maintenance, emission control system 10-2 |
| | Brake fluid, changing..... 10-22 | | Fuel meter 7-8 | Matte color, caution..... 11-1 |
| | Brake fluid level, checking..... 10-21 | | Fuel tank cap..... 7-12 | Multi-function display 7-8 |
| | Brake lever, front 7-11 | | Fuses, replacing..... 10-28 | Multi-function meter unit 7-7 |
| | Brake lever, rear 7-12 | H | | O |
| | Brake levers, lubricating 10-23 | | Handlebar switches 7-10 | Operating range of the smart key system 4-2 |
| | Brake pads and shoes, checking 10-20 | | Headlight..... 10-29 | P |
| | Braking 9-4 | | Helmet holders..... 7-16 | Panels, removing and installing 10-8 |
| C | | | Helmets..... 2-6 | Parking..... 9-4 |
| | Cables, checking and lubricating 10-23 | | High beam indicator light..... 7-6 | Part locations..... 3-1 |
| | Care 11-1 | | Horn switch 7-11 | Precautions when using the Stop and Start System..... 6-3 |
| | Catalytic converter 7-14 | I | | R |
| | CCU (Communication Control Unit) 5-1 | | Identification numbers 13-1 | Rear brake lever free play, adjusting..... 10-20 |
| | Centerstand and sidestand, checking and lubricating 10-24 | | Ignition circuit cut-off system 7-20 | S |
| | Clock 7-9 | | Incoming call indicator light (If CCU is equipped)..... 7-6 | Safe-riding points 2-5 |
| D | | | Incoming notification indicator light (If CCU is equipped)..... 7-6 | Safety information..... 2-1 |
| | Data recording, vehicle..... 13-2 | | Indicator lights and warning lights 7-5 | Scanning the CCU QR code..... 5-3 |
| | Dimmer switch..... 7-11 | | Initial setup: Yamaha Motorcycle Connect app 5-1 | Seat..... 7-15 |
| E | | K | | Sidestand..... 7-19 |
| | Eco indicator 7-10 | | Keyhole shutter 7-5 | Smart key battery 4-4 |
| | Emergency mode (LCF125-F) 10-33 | | Kickstarter..... 7-15 | Smart key system 4-1 |
| | Engine break-in 9-1 | L | | Smart key system indicator light 7-6 |
| | Engine oil and oil strainer 10-10 | | Labels, location 1-1 | Smart key system, troubleshooting.... 10-30 |
| | Engine serial number 13-1 | | | Smartphone battery level meter 7-7 |
| | Engine trouble warning light..... 7-6 | | | |

Index

Spark plug, checking 10-9
Specifications 12-1
Speedometer 7-7
Starting off 9-3
Starting the engine..... 9-2
Start switch 7-11
Steering, checking 10-25
Stop and Start System 6-1
Stop and Start System indicator light..... 7-6
Stop and Start System operation 6-1
Stop and Start System switch 7-11
Stop and Start System
troubleshooting 10-30
Storage 11-3
Storage compartments 7-17

T

Throttle grip and cable, checking
and lubricating 10-23
Throttle grip free play, checking 10-16
Tires 10-17
Tool kit 10-1
Troubleshooting 10-30
Troubleshooting chart..... 10-32
Turn signal indicator light 7-5
Turn signal switch 7-11

U

USB Type-A jack 7-18

V

Valve clearance..... 10-17
V-belt, checking 10-22
Vehicle identification number 13-1

W

Wheel bearings, checking..... 10-26
Wheels 10-19

Y

Yamaha Motorcycle Connect icon 7-7
Yamalube 10-12

Yamaha Motorcycle Connect (If CCU is equipped)

