



OWNER'S MANUAL

**⚠ Read this manual carefully  
before operating this vehicle.**

**TRACER 9  
GT+**

MOTORCYCLE

**MTT890D-SK (Tracer 9 GT+ Y-AMT)**

BVV-2U199-E0

Location of important labels	1
Safety information	2
Description	3
Special features	4
Smartphone Connectivity System	5
Instrument and control functions	6
For your safety – pre-operation checks	7
Operation and important riding points	8
Periodic maintenance and adjustment	9
Motorcycle care and storage	10
Specifications	11
Consumer information	12
Index	13

**⚠ Read this manual carefully before operating this vehicle. This manual should stay with this vehicle if it is sold.**

**ระบบบันทึกข้อมูลการขับขี่/กฎจราจรอัจฉริยะ**



เครื่องโทรคมนาคมและอุปกรณ์นี้ มีความสอดคล้องตามมาตรฐานหรือข้อกำหนดทางเทคนิคของ กสทช.

**เรดาร์แบบคลื่นมิลลิเมตร**



This telecommunication equipment “BOSCH Radar Sensor MRRe14FCR/MRR1rear” conforms to technical standard NTC TS 1011-2549.

This telecommunication equipment “BOSCH Radar Sensor MRRe14FCR/MRR1rear” has EMF radiation and conforms to NTC exposure standard NTC TS 5001-2550.

This equipment “BOSCH Radar Sensor MRRe14FCR/MRR1rear” is operating more than 20cm away from human body in normal operating condition.

- 1) เครื่องโทรคมนาคมและอุปกรณ์นี้ มีความสอดคล้องตามมาตรฐานหรือข้อกำหนดของ กสทช.
- 2) เครื่องวิทยุคมนาคมนี้มีระดับการแผ่คลื่นแม่เหล็กไฟฟ้าสอดคล้องตามมาตรฐานความปลอดภัยต่อสุขภาพของมนุษย์จากการใช้เครื่องวิทยุคมนาคมที่คณะกรรมการกิจการโทรคมนาคมแห่งชาติประกาศกำหนด

**Use of trade marks**

The Bluetooth<sup>®</sup> word mark and logos are registered trademarks owned by Bluetooth SIG, Inc.

Wi-Fi<sup>®</sup> is a registered trademark of Wi-Fi Alliance<sup>®</sup>

iOS is a registered trademark or trademark of Cisco Systems, Inc. and/or its affiliates in the United States and certain other countries.

# Introduction

---

EAU10103

Welcome to the Yamaha world of motorcycling!

As the owner of the MTT890D-SK, you are benefiting from Yamaha's vast experience and newest technology regarding the design and manufacture of high-quality products, which have earned Yamaha a reputation for dependability.

Please take the time to read this manual thoroughly, so as to enjoy all advantages of your MTT890D-SK. The Owner's Manual does not only instruct you in how to operate, inspect and maintain your motorcycle, but also in how to safeguard yourself and others from trouble and injury.

In addition, the many tips given in this manual will help keep your motorcycle in the best possible condition. If you have any further questions, do not hesitate to contact your Yamaha dealer.

The Yamaha team wishes you many safe and pleasant rides. So, remember to put safety first!

Yamaha continually seeks advancements in product design and quality. Therefore, while this manual contains the most current product information available at the time of printing, there may be minor discrepancies between your motorcycle and this manual. If there is any question concerning this manual, please consult a Yamaha dealer.

EWA10032



---



**Please read this manual carefully and completely before operating this motorcycle.**

---

# Important manual information

EAU10134

Particularly important information is distinguished in this manual by the following notations:

	<b>This is the safety alert symbol. It is used to alert you to potential personal injury hazards. Obey all safety messages that follow this symbol to avoid possible injury or death.</b>
	<b>A WARNING indicates a hazardous situation which, if not avoided, could result in death or serious injury.</b>
	<b>A NOTICE indicates special precautions that must be taken to avoid damage to the vehicle or other property.</b>
<b>TIP</b>	<b>A TIP provides key information to make procedures easier or clearer.</b>

\*Product and specifications are subject to change without notice.

# Important manual information

---

EAU10202

**MTT890D-SK  
OWNER'S MANUAL  
©2025 by Yamaha Motor Co., Ltd.  
1st edition, February 2025  
All rights reserved.  
Any reprinting or unauthorized use  
without the written permission of  
Yamaha Motor Co., Ltd.  
is expressly prohibited.  
Printed in Japan.**

# Table of contents

<b>Location of important labels</b> .....	1-1	TPMS (Tire pressure monitoring system) .....	4-31	Fuel .....	6-42
<b>Safety information</b> .....	2-1	Smart key system .....	4-31	Fuel tank overflow hose .....	6-43
Helmets .....	2-5	Operating range of the smart key system .....	4-32	Catalytic converter .....	6-44
<b>Description</b> .....	3-1	Handling of the smart key and mechanical key .....	4-33	Seats .....	6-44
Left view .....	3-1	Smart key .....	4-35	Adjusting the rider seat height .....	6-45
Right view .....	3-2	Replacing the smart key battery .....	4-35	Rider footrest position .....	6-47
Controls and instruments .....	3-3	Main switch .....	4-37	Storage compartment .....	6-48
<b>Special features</b> .....	4-1	Fuel tank cap opening and closing .....	4-40	Handlebar position .....	6-49
Matrix LED headlight .....	4-1	<b>Smartphone Connectivity System</b> .....	5-1	Sidecake support holder .....	6-49
Cornering lights .....	4-5	Smart features (communication control unit) .....	5-1	Adjusting the front and rear suspension .....	6-49
Millimeter-wave radar .....	4-5	Initial setup .....	5-3	DC connectors .....	6-51
Rider intervention request .....	4-8	Navigation system: Garmin Motorize .....	5-7	USB jack(s) .....	6-51
FCW (Forward Collision Warning) .....	4-9	Telephone .....	5-8	Sidestand .....	6-52
BSD (Blind Spot Detection) .....	4-10	Connection troubleshooting .....	5-10	Ignition circuit cut-off system .....	6-53
Adaptive Cruise Control (ACC) system .....	4-12	<b>Instrument and control functions</b> .....	6-1	<b>For your safety – pre-operation checks</b> .....	7-1
ACC system operation .....	4-14	Handlebar switches .....	6-1	<b>Operation and important riding points</b> .....	8-1
Yamaha variable speed limiter (YVSL) .....	4-18	Indicator lights and warning lights .....	6-4	Engine break-in .....	8-1
Brake system .....	4-20	Display .....	6-7	Starting the engine .....	8-2
YRC (Yamaha Ride Control) .....	4-23	Pop-up menu system .....	6-20	Shifting .....	8-3
Y-AMT (Yamaha-Automated Manual Transmission) .....	4-27	Brake lever .....	6-41	Tips for reducing fuel consumption .....	8-5
ESS (emergency stop signaling) system .....	4-28	Brake pedal .....	6-41	Parking .....	8-5
Pre-ride Suspension Damping system .....	4-29			<b>Periodic maintenance and adjustment</b> .....	9-1
VHC (Vehicle hold control) .....	4-30			Tool kits .....	9-2

# Table of contents

---

Periodic maintenance chart for the emission control system.....	9-3	Checking and lubricating the brake pedal .....	9-23
General maintenance and lubrication chart .....	9-4	Checking and lubricating the centerstand and sidestand.....	9-24
Checking the spark plugs .....	9-8	Lubricating the swingarm pivots.....	9-24
Canister .....	9-9	Checking the front fork .....	9-25
Engine oil .....	9-9	Checking the steering.....	9-25
Why Yamalube .....	9-11	Checking the wheel bearings.....	9-26
Coolant.....	9-12	Battery.....	9-26
Air filter element.....	9-13	Replacing the fuses .....	9-27
Checking the engine idling speed ...	9-13	Vehicle lights .....	9-29
Valve clearance .....	9-14	Replacing the license plate light bulb.....	9-30
Tires .....	9-14	Troubleshooting .....	9-31
Cast wheels.....	9-16	Troubleshooting chart.....	9-33
Checking the brake lever free play .....	9-17	Emergency mode .....	9-35
Brake light switches.....	9-17	<b>Motorcycle care and storage</b> .....	10-1
Checking the front and rear brake pads .....	9-18	Matte color caution.....	10-1
Checking the brake fluid level .....	9-18	Care.....	10-1
Changing the brake fluid.....	9-20	Storage .....	10-3
Drive chain slack.....	9-20	<b>Specifications</b> .....	11-1
Cleaning and lubricating the drive chain.....	9-22	<b>Consumer information</b> .....	12-1
Checking and lubricating the cables .....	9-22	Identification numbers.....	12-1
Checking and lubricating the throttle grip.....	9-23	Diagnostic connector .....	12-2
Checking and lubricating the brake lever .....	9-23	Use of your data.....	12-3
		<b>Index</b> .....	13-1

# Location of important labels

EAU10387

1

Read and understand all of the labels on your vehicle. They contain important information for safe and proper operation of your vehicle. Never remove any labels from your vehicle. If a label becomes difficult to read or comes off, a replacement label is available from your Yamaha dealer.

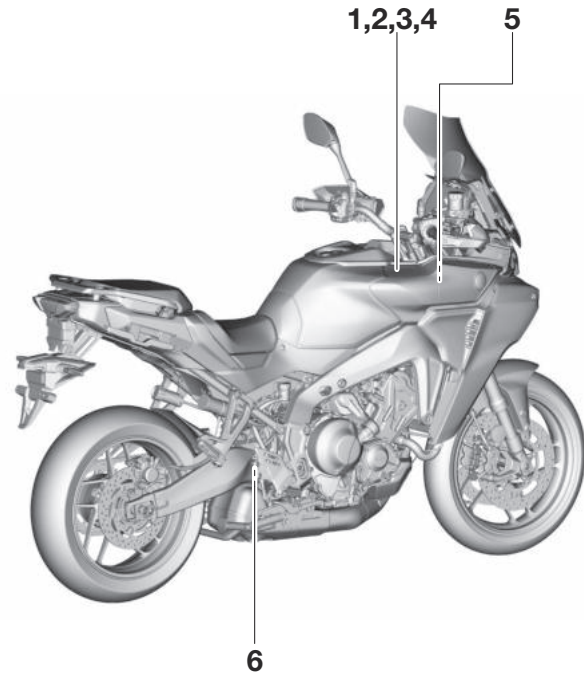
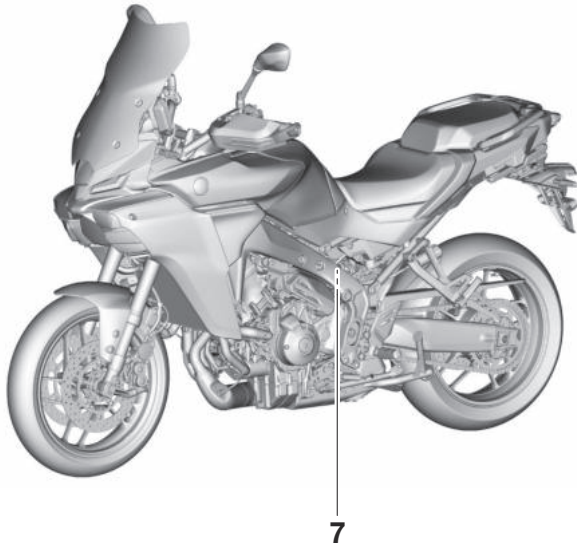

# Location of important labels

1

1



2

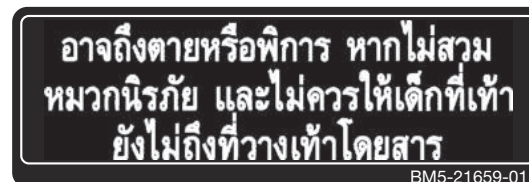

3

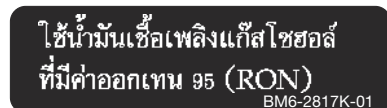

4



5



6

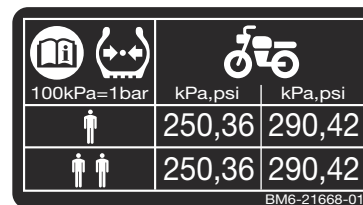

7



1

EAU1028D

2

## Be a Responsible Owner

As the vehicle's owner, you are responsible for the safe and proper operation of your motorcycle.

Motorcycles are single-track vehicles. Their safe use and operation are dependent upon the use of proper riding techniques as well as the expertise of the operator. Every operator should know the following requirements before riding this motorcycle.

He or she should:

- Obtain thorough instructions from a competent source on all aspects of motorcycle operation.
- Observe the warnings and maintenance requirements in this Owner's Manual.
- Obtain qualified training in safe and proper riding techniques.
- Obtain professional technical service as indicated in this Owner's Manual and/or when made necessary by mechanical conditions.

- Never operate a motorcycle without proper training or instruction. Take a training course. Beginners should receive training from a certified instructor. Contact an authorized motorcycle dealer to find out about the training courses nearest you.

## Safe Riding

Perform the pre-operation checks each time you use the vehicle to make sure it is in safe operating condition. Failure to inspect or maintain the vehicle properly increases the possibility of an accident or equipment damage. See page 7-1 for a list of pre-operation checks.

- This motorcycle is designed to carry the operator and a passenger.
- The failure of motorists to detect and recognize motorcycles in traffic is the predominating cause of automobile/motorcycle accidents. Many accidents have been caused by an automobile driver who did not see the motorcycle. Making yourself conspicuous appears to

be very effective in reducing the chance of this type of accident.

### Therefore:

- Wear a brightly colored jacket.
- Use extra caution when you are approaching and passing through intersections, since intersections are the most likely places for motorcycle accidents to occur.
- Ride where other motorists can see you. Avoid riding in another motorist's blind spot.
- Never maintain a motorcycle without proper knowledge. Contact an authorized motorcycle dealer to inform you on basic motorcycle maintenance. Certain maintenance can only be carried out by certified staff.
- Many accidents involve inexperienced operators. In fact, many operators who have been involved in accidents do not even have a current motorcycle license.
- Make sure that you are qualified and that you only lend your motorcycle to other qualified operators.

- Know your skills and limits. Staying within your limits may help you to avoid an accident.
- We recommend that you practice riding your motorcycle where there is no traffic until you have become thoroughly familiar with the motorcycle and all of its controls.
- Many accidents have been caused by error of the motorcycle operator. A typical error made by the operator is veering wide on a turn due to excessive speed or undercornering (insufficient lean angle for the speed).
  - Always obey the speed limit and never travel faster than warranted by road and traffic conditions.
  - Always signal before turning or changing lanes. Make sure that other motorists can see you.
- The posture of the operator and passenger is important for proper control.
  - The operator should keep both hands on the handlebar and both feet on the operator foot-

ests during operation to maintain control of the motorcycle.

- The passenger should always hold onto the operator, the seat strap or grab bar, if equipped, with both hands and keep both feet on the passenger footrests. Never carry a passenger unless he or she can firmly place both feet on the passenger footrests.
- Never ride under the influence of alcohol or other drugs.
- This motorcycle is designed for on-road use only. It is not suitable for off-road use.

### **Protective Apparel**

The majority of fatalities from motorcycle accidents are the result of head injuries. The use of a safety helmet is the single most critical factor in the prevention or reduction of head injuries.

- Always wear an approved helmet.
- Wear a face shield or goggles. Wind in your unprotected eyes could contribute to an impairment of vision that could delay seeing a hazard.

- The use of a jacket, heavy boots, trousers, gloves, etc., is effective in preventing or reducing abrasions or lacerations.
- Never wear loose-fitting clothes, otherwise they could catch on the control levers, footrests, or wheels and cause injury or an accident.
- Always wear protective clothing that covers your legs, ankles, and feet. The engine or exhaust system become very hot during or after operation and can cause burns.
- A passenger should also observe the above precautions.

### **Avoid Carbon Monoxide Poisoning**

All engine exhaust contains carbon monoxide, a deadly gas. Breathing carbon monoxide can cause headaches, dizziness, drowsiness, nausea, confusion, and eventually death.

Carbon Monoxide is a colorless, odorless, tasteless gas which may be present even if you do not see or smell any engine exhaust. Deadly levels of carbon monoxide can collect rapidly and you can quickly be overcome and unable to save yourself. Also, deadly

## Safety information

2

levels of carbon monoxide can linger for hours or days in enclosed or poorly ventilated areas. If you experience any symptoms of carbon monoxide poisoning, leave the area immediately, get fresh air, and SEEK MEDICAL TREATMENT.

- Do not run engine indoors. Even if you try to ventilate engine exhaust with fans or open windows and doors, carbon monoxide can rapidly reach dangerous levels.
- Do not run engine in poorly ventilated or partially enclosed areas such as barns, garages, or carports.
- Do not run engine outdoors where engine exhaust can be drawn into a building through openings such as windows and doors.

### Loading

Adding accessories or cargo to your motorcycle can adversely affect stability and handling if the weight distribution of the motorcycle is changed. To avoid the possibility of an accident, use extreme caution when adding cargo or accessories to your motorcycle. Use

extra care when riding a motorcycle that has added cargo or accessories. Here, along with the information about accessories below, are some general guidelines to follow if loading cargo to your motorcycle:

The total weight of the operator, passenger, accessories and cargo must not exceed the maximum load limit.

**Operation of an overloaded vehicle could cause an accident.**

**Maximum load:**  
197 kg (434 lb)

When loading within this weight limit, keep the following in mind:

- Cargo and accessory weight should be kept as low and close to the motorcycle as possible. Securely pack your heaviest items as close to the center of the vehicle as possible and make sure to distribute the weight as evenly as possible on both sides of the motorcycle to minimize imbalance or instability.
- Shifting weights can create a sudden imbalance. Make sure that ac-

cessories and cargo are securely attached to the motorcycle before riding. Check accessory mounts and cargo restraints frequently.

- Properly adjust the suspension for your load (suspension-adjustable models only), and check the condition and pressure of your tires.
- Never attach any large or heavy items to the handlebar, front fork, or front fender. These items, including such cargo as sleeping bags, duffel bags, or tents, can create unstable handling or a slow steering response.
- **This vehicle is not designed to pull a trailer or to be attached to a sidecar.**

### Genuine Yamaha Accessories

Choosing accessories for your vehicle is an important decision. Genuine Yamaha accessories, which are available only from a Yamaha dealer, have been designed, tested, and approved by Yamaha for use on your vehicle.

Many companies with no connection to Yamaha manufacture parts and accessories or offer other modifications for Yamaha vehicles. Yamaha is not in a position to test the products that these aftermarket companies produce. Therefore, Yamaha can neither endorse nor recommend the use of accessories not sold by Yamaha or modifications not specifically recommended by Yamaha, even if sold and installed by a Yamaha dealer.

### **Aftermarket Parts, Accessories, and Modifications**

While you may find aftermarket products similar in design and quality to genuine Yamaha accessories, recognize that some aftermarket accessories or modifications are not suitable because of potential safety hazards to you or others. Installing aftermarket products or having other modifications performed to your vehicle that change any of the vehicle's design or operation characteristics can put you and others at greater risk of serious injury or death. You are responsible for injuries related to changes in the vehicle.

Keep the following guidelines in mind, as well as those provided under “Loading” when mounting accessories.

- Never install accessories or carry cargo that would impair the performance of your motorcycle. Carefully inspect the accessory before using it to make sure that it does not in any way reduce ground clearance or cornering clearance, limit suspension travel, steering travel or control operation, or obscure lights or reflectors.
- Accessories fitted to the handlebar or the front fork area can create instability due to improper weight distribution or aerodynamic changes. If accessories are added to the handlebar or front fork area, they must be as lightweight as possible and should be kept to a minimum.
- Bulky or large accessories may seriously affect the stability of the motorcycle due to aerodynamic effects. Wind may attempt to lift the motorcycle, or the motorcycle may become unstable in cross winds. These

accessories may also cause instability when passing or being passed by large vehicles.

- Certain accessories can displace the operator from his or her normal riding position. This improper position limits the freedom of movement of the operator and may limit control ability, therefore, such accessories are not recommended.
- Use caution when adding electrical accessories. If electrical accessories exceed the capacity of the motorcycle's electrical system, an electric failure could result, which could cause a dangerous loss of lights or engine power.

### **Aftermarket Tires and Rims**

The tires and rims that came with your motorcycle were designed to match the performance capabilities and to provide the best combination of handling, braking, and comfort. Other tires, rims, sizes, and combinations may not be appropriate. See page 9-14 for tire specifications and for information on servicing and replacing your tires.

## Safety information

2

### Transporting the Motorcycle

Be sure to observe following instructions before transporting the motorcycle in another vehicle.

- Remove all loose items from the motorcycle.
- Check that the fuel cock (if equipped) is in the off position and that there are no fuel leaks.
- Shift the transmission into gear (for models with a manual transmission).
- Secure the motorcycle with tie-downs or suitable straps that are attached to solid parts of the motorcycle, such as the frame or upper front fork triple clamp (and not, for example, to rubber-mounted handlebars or turn signals, or parts that could break). Choose the location for the straps carefully so the straps will not rub against painted surfaces during transport.
- The suspension should be compressed somewhat by the tie-downs, if possible, so that the motorcycle will not bounce excessively during transport.

### Helmets

Operating this vehicle without an approved motorcycle helmet increases your chances of a severe head injury or death in the event of an accident. The majority of fatalities from motorcycle or scooter accidents are the result of head injuries. The use of a safety helmet is the single most critical factor in the prevention or reduction of head injuries.

#### Always select an approved motorcycle helmet

Pay attention to the following when choosing a motorcycle helmet.

- The helmet must meet the safety standard “TIS”.
- The helmet size must match the size of the rider’s head.
- Never subject a helmet to heavy shocks.

#### Wearing the helmet correctly

Always connect the chin strap. In the case of an accident, the helmet has a much less chance of coming off if the chin strap is connected.

EAUJ0033

### Correct usage



ZAUU0003

### Wrong usage



ZAUU0007

### Types of helmets and their usage

- Half-type: use only for riding at low speeds



ZAUU0004

- Full-type: use only for riding at low to mid-range speeds



ZAUU0006



ZAUU0005

- Full-face-type: use for riding at mid-range to high speeds

# Description

EAU10411

## Left view

3

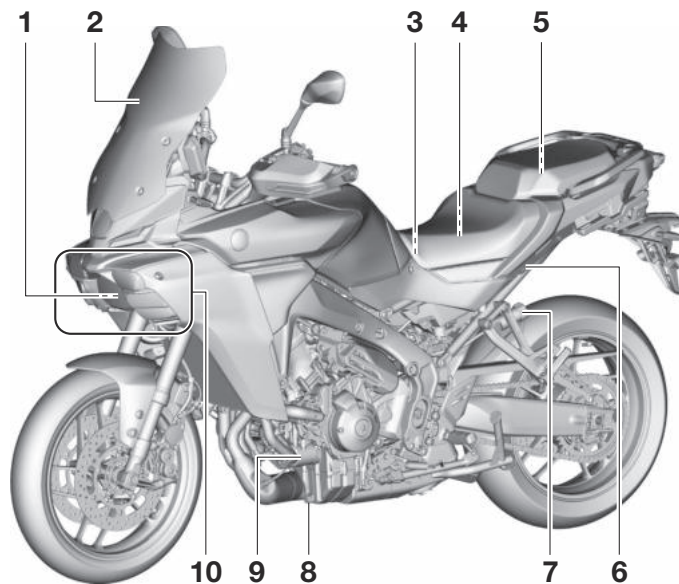

1. Millimeter-wave radar unit (page 4-5)

2. Windscreen (page 6-28)

3. Battery (page 9-26)

4. Fuses (page 9-27)

5. Tool kit (page 9-2)

6. Seat lock (page 6-44)

7. Spring preload adjuster (page 6-49)

8. Engine oil drain bolt (page 9-9)

9. Oil filter cartridge (page 9-9)

10. Matrix LED headlight (page 4-1)

## Right view

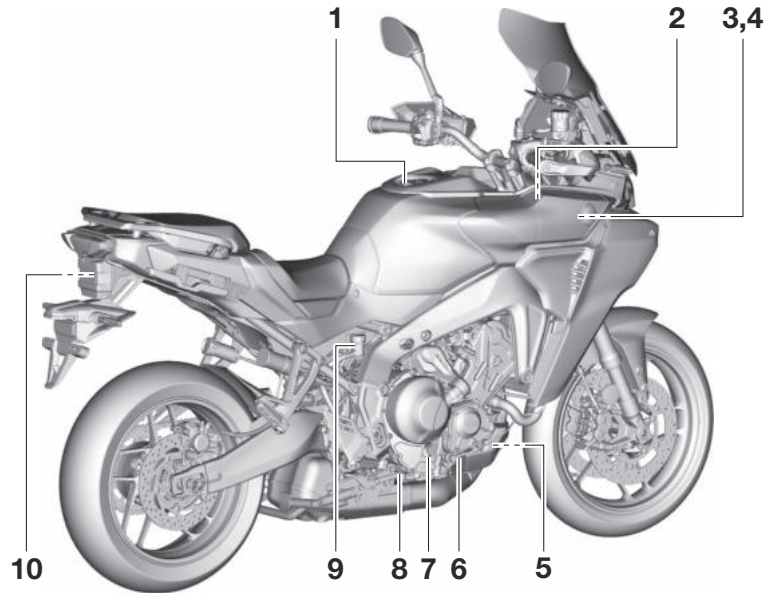

1. Fuel tank cap (page 4-40)
2. Spring preload adjuster (page 6-49)
3. Storage compartment (page 6-48)
4. USB Type-A jack (page 6-51)
5. Coolant reservoir (page 9-12)
6. Engine oil level check window (page 9-9)
7. Engine oil filler cap (page 9-9)
8. Brake pedal (page 6-41)
9. Rear brake fluid reservoir (page 9-18)
10. Millimeter-wave radar unit (page 4-5)

# Description

EAU10431

## Controls and instruments

3

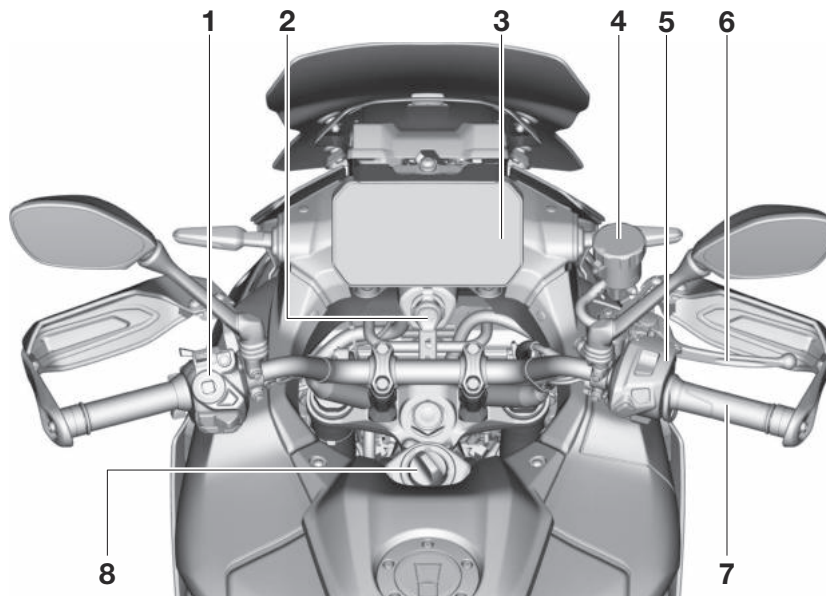

1. Left handlebar switches (page 6-1)
2. USB Type-C jack (page 6-51)
3. Display (page 6-7)
4. Front brake fluid reservoir (page 9-18)
5. Right handlebar switches (page 6-1)
6. Brake lever (page 6-41)
7. Throttle grip (page 9-23)
8. Main switch (page 4-37)

## Matrix LED headlight

EAUJ4316

The matrix LED headlight consists of multiple LEDs aimed at different angles. They are activated in different patterns to provide low beam, high beam, adaptive high beam and cornering light functions.

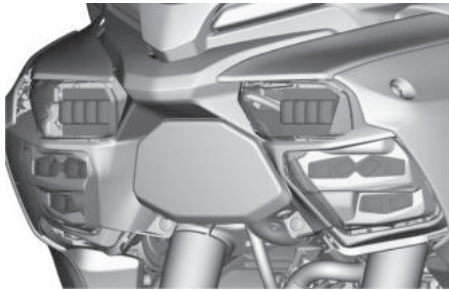

## Adaptive high beam

When the adaptive high beam is active, the front mounted camera detects oncoming vehicles, vehicles ahead, and ambient light. The high beam LED pattern is then automatically adjusted to prevent glare for other vehicles.

The detection speed of the camera and left/right driving lane setting can be ad-

justed in the menu system. (See page 6-20.)

## No oncoming or vehicles ahead

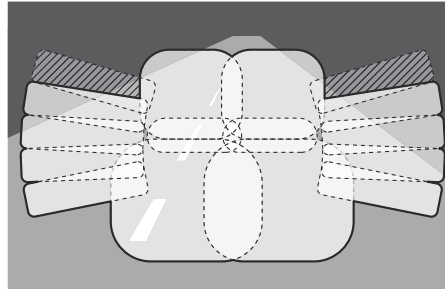

## Oncoming vehicle

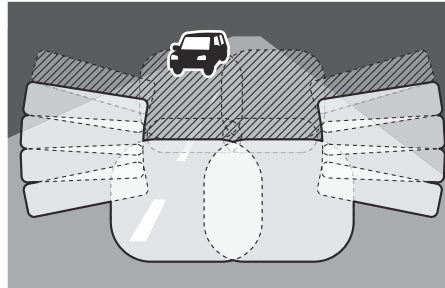

## Oncoming vehicle approached

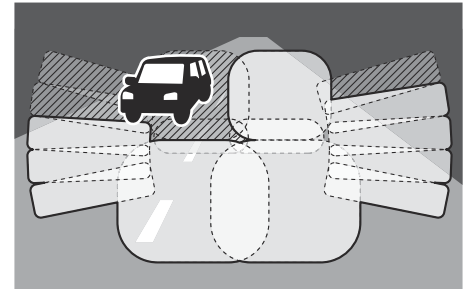

## Passing an oncoming vehicle

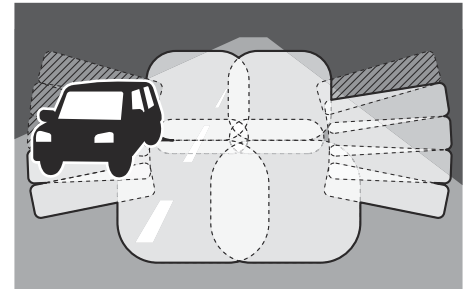

# Special features

Oncoming vehicle while leaning

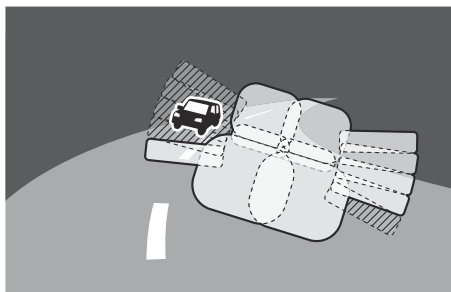

Vehicle ahead



Adaptive high beam off (when cornering)



No vehicle ahead

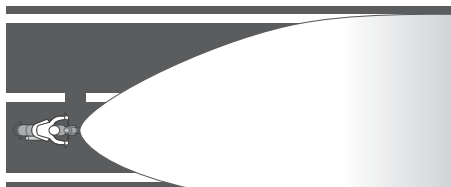

Oncoming vehicle



Adaptive high beam on (when cornering)



## Adaptive high beam on (when cornering, oncoming vehicles)

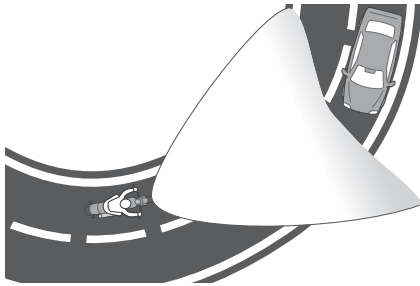

Press and hold the headlight switch in the outward direction to turn on the adaptive high beam function and the adaptive high beam indicator “” will come on in green.

The high beam LEDs will then turn on/off automatically as you ride above 20 km/h (12 mi/h) based on detected vehicles and lighting conditions.

When the high beam LEDs come on in adaptive high beam mode, the high beam indicator light “” will also come on.

The adaptive high beam does not operate in the following conditions:

- Vehicle speed below 15 km/h (9 mi/h)

- Environments with adequate street lighting
- Foggy weather
- Daylight

EWA22870

### **WARNING**

The adaptive high beam is intended to boost road visibility and decrease rider fatigue. Camera detection can be effected by road conditions, weather, vehicle posture, etc. Riders shall always maintain awareness of their surroundings and road conditions, and manually operate the vehicle headlights as needed.

ECA28751

### **NOTICE**

Adaptive high beam may not work properly in the following cases:

- The camera cover is dirty (dust, mud, insects, etc.), deteriorated or damaged.
- An object, sticker or film is attached to any portion of around the camera cover.
- Put water repellent glass coating agent the camera cover

- The vehicle is tilted with a heavy load in the rear.
- Bad weather obstructs the camera (fog, heavy rain, snow, etc.)
- A vehicle ahead trailing smoke, or water and obstructing the camera.
- Twilight conditions.
- Light sources such as street lamps, signage, traffic lights, reflect strongly from the road surface.
- Reflective objects such as signs, mirrors, traffic cones, etc. reflect light strongly back at the camera.
- Roads with sudden elevation changes.
- The lights of other vehicles on the road are too strong or weak.
- Objects suddenly appear in front of the vehicle.
- Objects appear from behind the vehicle (passing vehicles, etc.)
- Objects are obstructed from the camera by other objects such as trees, street signs, road medians, etc.

## Special features

4

- Objects in front are small (bicycles, scooters, etc.)
- Other vehicles have very reflective surfaces.
- Distances to other vehicles are too large/small.
- Vehicle speed is too high.
- The vehicle stance changes suddenly (sharp turns, hard braking, etc.)

When an error occurs with the adaptive high beam, the adaptive high beam indicator will turn amber “”.

If this occurs, park the vehicle in a safe place and clean the camera cover. After traveling some distance, if the indicator does not turn green “”, have a Yamaha dealer inspect the vehicle.

To clean the camera cover:

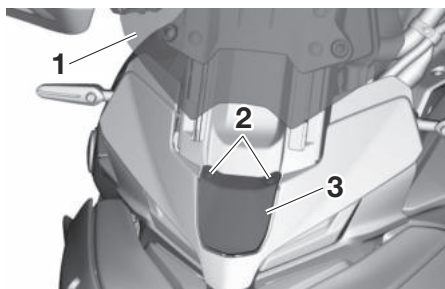

1. Windscreen
2. Quick fastener
3. Camera cover

If the camera cover is too dirty the adaptive high beam cannot function properly. If the inside face of the camera cover becomes dirty, clean it and the outside face using the following procedure:

1. Ensure the windscreen is in the high position and is not blocking access to the camera cover.
2. Remove the camera cover by removing the quick fasteners and then pulling the cover upward.
3. Clean the camera cover with a soft towel or sponge dampened with

water and a pH neutral detergent. If necessary, use a high quality windscreen cleaner. **NOTICE:** Never use any strong chemicals to clean the camera cover. Additionally, some cleaning compounds for plastic may scratch the camera cover, so be sure to test all cleaning products before general application. [ECA28810]

4. Rinse off thoroughly with clean water. Be sure to remove all detergent residues, as they can be harmful to plastic parts.
5. Place the camera cover and install the quick fasteners.

The detection speed of the camera and left/right driving lane setting can be adjusted in the menu system. (See page 6-20.)

EAU4842



EAU5683

## Cornering lights

This model is equipped LED lights angled to the sides for use as cornering lights.

The cornering lights automatically come on in the cornering direction when the vehicle is leaned.

The cornering headlights operate when the headlights are set to low beam “”.

They do not operate when the headlights are set to high beam “” or adaptive high beam “”.

## Millimeter-wave radar

This vehicle is equipped with two millimeter-wave radar units mounted at the front and rear. The front radar detects and measures the distance to vehicles ahead, enabling operation of the adaptive cruise control (ACC) system (page 4-12), radar-linked unified braking (UBS) system (page 4-21), and forward collision warning (FCW) system (page 4-9). The rear radar enables operation of the blind spot detection (BSD) system (page 4-10).

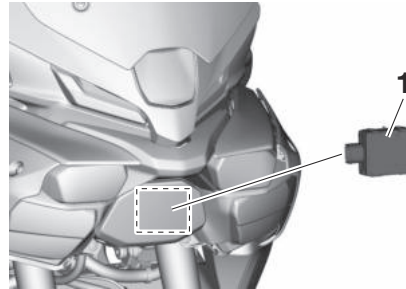

1. Millimeter-wave radar unit

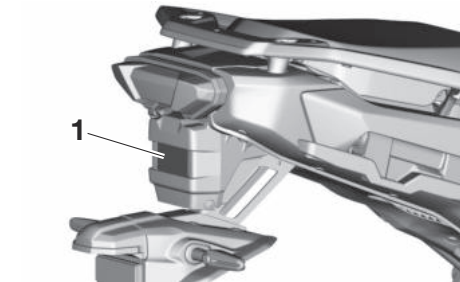
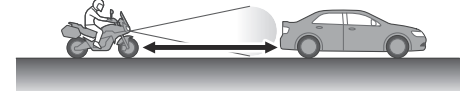

1. Millimeter-wave radar unit

# Special features

4

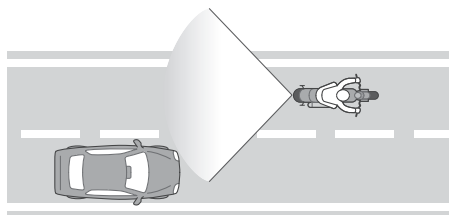

EWA22930

## **⚠ WARNING**

To ensure optimal functionality of the millimeter-wave radar and its related systems, it's important to follow specific guidelines and understand the system limitations.

### ● General guidelines:

- Avoid placing stickers or paint on or around the radar unit, as this may impair performance.
- Keep the radar unit free from obstructions, mud, ice, or debris. Modifying or attaching accessories near the unit can interfere with detection capabilities.

- After an accident, fall, or strong impact, the radar unit may become misaligned. If misalignment is suspected, have a Yamaha dealer inspect the vehicle.
- The millimeter-wave radar may not operate properly in the following environments:
  - Locations with electromagnetic interference
  - Tunnels
  - Near guardrails or other objects
  - Heavy weather (rain, snow, hail, etc.)
  - Road construction zones
- The radar related systems may not function correctly under the following conditions:
  - Roads with pedestrian or bicycle traffic
  - Heavy traffic with frequent lane changes
  - Curvy roads
  - Slippery or uneven roads
  - Non-public or unpaved roads
- The radar may not accurately detect other vehicles in the following situations:
  - When riding on the far side of the lane
  - When the vehicle ahead is too far to either side of the lane
  - Meandering or unstable steering
  - If the vehicle is overloaded, causing it to point upward
  - If a vehicle in an adjacent lane is driving too close
  - If the vehicle is overloaded, causing it to point upward
  - While traveling steeply uphill or downhill
- The following may not be detected accurately or at all, even if they are in the same lane:
  - Parked vehicles or those stopped in traffic
  - Stationary objects (e.g., tunnels, guardrails, toll booths)
  - Pedestrians, bicycles, and animals
  - Motorcycles splitting lanes too closely

- Tall vehicles or those with long cargo beds
- Flying objects (e.g., balls, plastic bags, cans)
- Vehicles crossing in front of you

## Far side of lane

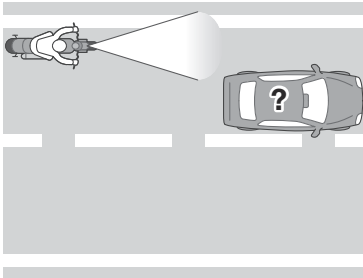

## Adjacent vehicle too close

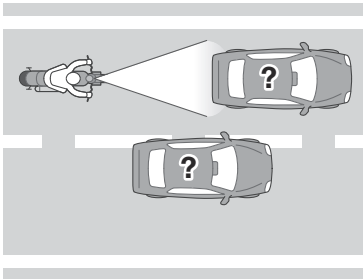

## Meandering (unstable) driving

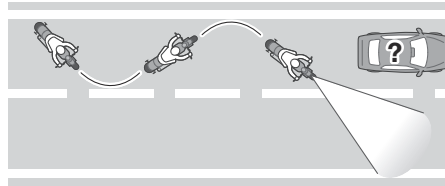

## Lane splitting

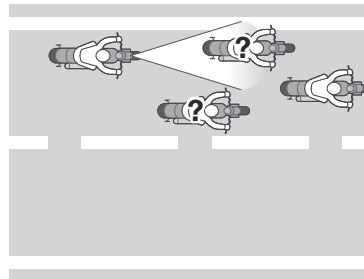

## Crossing vehicle

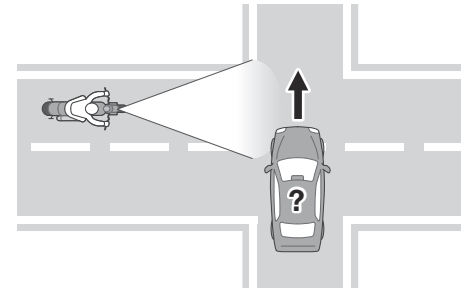

## Unusually shaped vehicle

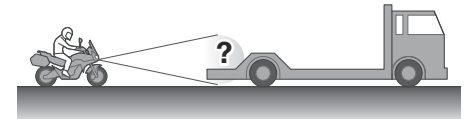

# Special features

## Sharp curves

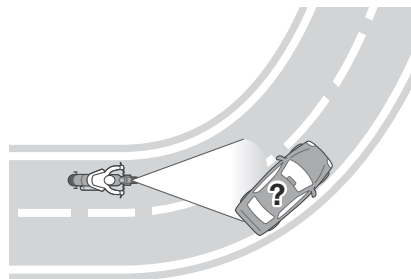

4

## Rider intervention request

EUAJ6601



1

### 1. Rider intervention request

When the display screen changes to show the rider intervention request, immediately take full control of the vehicle and assess the situation.

When the rider intervention request appears, the display will reconfigure to the minimized display view with an orange background. The icon in the middle will flash. The rider intervention request will be displayed in the following situations:

Adaptive cruise control (ACC) is on:

- When the vehicle ahead is too close.

- When the current vehicle speed is judged to be too fast compared to vehicle ahead.

Forward collision warning (FCW) is on:

- When a vehicle ahead is detected too close.

EWA22540

## WARNING

**The rider intervention request is not guaranteed to display under all circumstances. The rider intervention request may not be displayed or be delayed in some circumstances. Always be aware of the surrounding environment and traffic conditions and be ready to take full control of the vehicle.**

## FCW (Forward Collision Warning)

EAUJA5693

### **WARNING**

EWA22940

Always maintain a safe following distance and stay alert to traffic conditions ahead. This system does not replace safe riding practices. The rider is ultimately responsible for their own safety.

The Forward Collision Warning (FCW) system notifies riders of potential collisions when a vehicle ahead is detected too close.

The FCW system uses a front-facing millimeter-wave radar to detect vehicles ahead and provides a two-stage warning:

### Stage 1:

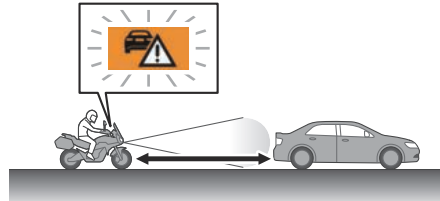

When a vehicle is detected within a medium distance, the Rider Intervention Request appears as a visual warning (see page 4-8). The warning continues until the detected vehicle leaves range.

EWA22540

### **WARNING**

**The rider intervention request is not guaranteed to display under all circumstances. The rider intervention request may not be displayed or be delayed in some circumstances. Always be aware of the surrounding environment and traffic conditions and be ready to take full control of the vehicle.**

### Stage 2:

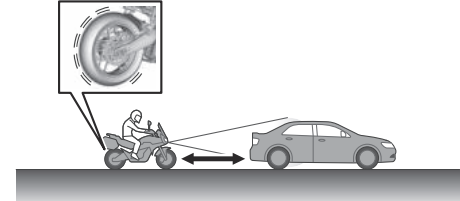

If the distance to the detected vehicle decreases and the rider does not engage the brakes, the rear brake will automatically pulse twice to provide a physical alert to the rider.

### FCW is active when:

- FCW is set to “Near” or “Normal” in the menu system (see page 6-40).
- TCS (traction control system) is ON (see page 6-33).
- Vehicle speed is above 30 km/h (20 mi/h).
- Lean angle is not too great.

# Special features

---

## TIP



---

- If the throttle grip is turned wide open and the system detects a clear intention by the rider to accelerate, FCW will not activate.
- Stage 1 warning has an upper speed limit of 200 km/h (124 mi/h). Stage 2 warning has an upper speed limit of 160 km/h (100 mi/h).

In the menu system, there are three FCW settings: “Near”, “Normal”, and “OFF”. The “Near” and “Normal” settings adjust the range at which detected vehicles trigger the system. Selecting “OFF” disables the FCW system and the FCW OFF indicator  will come on (see page 6-16).

## TIP

---

- If TCS is turned off in the menu system, the FCW OFF indicator  will come on.
- If the FCW OFF indicator  does not go off even when the FCW menu setting is “Near” or “Normal” and TCS is on, have the vehicle inspected by a Yamaha dealer.

- When the FCW is set to “OFF”, if the vehicle power is turned off then on, the FCW setting will change to “Near”. If the previous setting was “Near” or “Normal” the previous setting will be kept.
- 

## BSD (Blind Spot Detection)

EUAJ5703

EWA22951

### **WARNING**

---

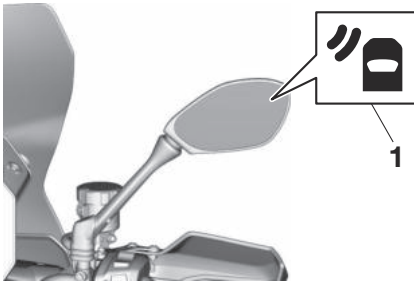
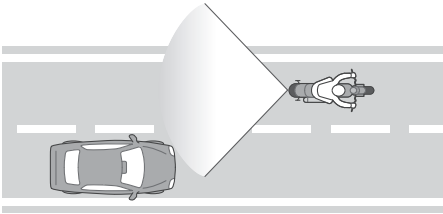

- **Always check your mirrors and look directly before changing lanes.**
  - **The BSD (Blind Spot Detection) system is designed to assist the rider with making lane change decisions, but it does not replace safe riding practices.**
  - **Since the system may not detect all vehicles, rely on direct visual checks to avoid accidents. BSD is not a substitute for the rider’s awareness of the surrounding traffic environment.**  
**The rider is responsible for their own safety.**
-



1. BSD indicator

The BSD (Blind Spot Detection) system uses a rear-facing millimeter-wave radar to detect vehicles in the rearward left and right areas, which may not be visible in the side mirrors or the rider's peripheral vision, and then alerts the rider with indicators in the side mirrors.

## Detection Alerts:

- When a vehicle enters the blind spot detection area or a vehicle rapidly approaches in the approach detection area, the BSD indicator “” light in the corresponding side mirror will come on.
- When a vehicle is detected in either of the above conditions and the turn signal is activated in the direction of detection, the BSD indicator “” light in the corresponding side mirror will flash.

## BSD operating conditions:

The system is active when all of the following conditions are met:

- BSD is set to ON in the menu system (see page 6-39).
- TCS (traction control system) is ON (see page 6-33).
- Vehicle speed is above approximately 20 km/h (12 mi/h).
- Lean angle is not too great.

If BSD or TCS is turned off in the menu system, the BSD OFF indicator “” will come on.

If either the BSD system or the rear millimeter-wave radar malfunctions, the auxiliary system warning icon “” will come on. If this occurs, have a Yamaha dealer inspect the vehicle.

## TIP

BSD will not function while ABS or TCS are currently engaged.

The BSD system may not detect under the following conditions:

- When another vehicle enters a detection zone at less than 7 km/h (4 mi/h).
- When your vehicle overtakes another vehicle at a speed of 4 km/h (2 mi/h) or more.
- When small motorcycles, bicycles, or pedestrians are present.
- When vehicles are two or more lanes away from your vehicle.
- When other objects (such as tunnels, guardrails, toll booths, or parked vehicles) are present.
- When there is a large difference in speed between your vehicle and another vehicle.

# Special features

## Adaptive Cruise Control (ACC) system

EUAU7061

EWA22571

### WARNING

- The ACC system is intended to increase rider comfort and reduce fatigue. It is not a safety or collision avoidance system. The responsibility for safety lies with the rider. Riders shall always maintain awareness of their surroundings and road conditions, and actively operate the vehicle to decelerate and accelerate safely.
- The ACC system works best on long, straight roads such as highways. It is not a substitute for the rider's awareness of the surrounding traffic environment.

This vehicle is equipped with an adaptive cruise control (ACC) system which assists in maintaining a set cruising speed and appropriate distance from vehicles ahead with only limited input needed by the rider.

The ACC system uses the equipped millimeter-wave radar unit to detect vehicles ahead in traffic and then automatically controls the engine, brakes, Y-AMT, and electronic suspension to maintain a set following distance.

While cruising with ACC, the vehicle speed is controlled as follows:

- With no vehicle ahead, vehicle speed will be the set cruising speed.

100 km/h (60 mi/h)

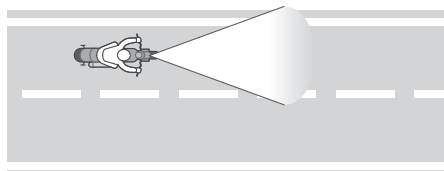

- When the system detects a vehicle ahead, it will continuously speed up/slow down to match speed with that vehicle (within limits of the set cruising speed).

80 km/h (50 mi/h)

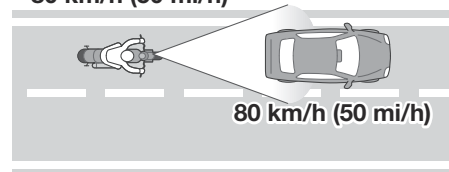

- When the system detects a vehicle ahead traveling slower than the set cruising speed, it will slow down to match speed with the vehicle ahead.

100 → 80 km/h  
(60 → 50 mi/h)

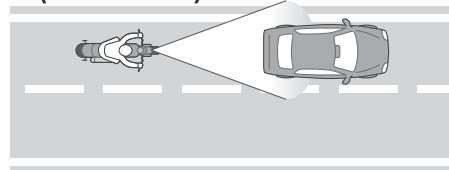

- When a vehicle ahead disappears from radar detection while speed is lower than the set cruising speed, it will accelerate to the set cruising speed.

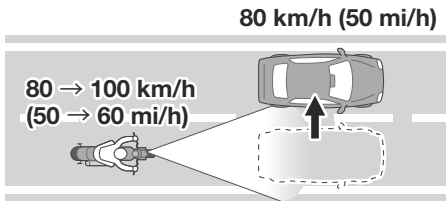

EWA22395

## **WARNING**

- Depending on the surrounding environment and traffic conditions, the ACC system may accelerate or decelerate unexpectedly. The rider must always be prepared to steer, accelerate, brake, and shift gears at any time.
- Cruising speed and following distance between vehicles shall be set according to local regulations.
- Set the following distance to a setting that is safe and appropriate for the weather, road and traffic conditions.

- To avoid accidental activation of the ACC system, turn it off (ACC indicator  is off) when not in use.
- The ACC system may not be able to accurately detect the movement of vehicles ahead depending on the situational conditions. While cruising with the ACC, operate the vehicle manually in the following situations:
  - Another vehicle suddenly cuts in front of you
  - The vehicle ahead suddenly brakes
  - The difference in speed with the vehicle ahead is very large
- Do not use the ACC system in the following situations, the ACC system may not operate properly and an accident may result:
  - Roads with pedestrian or bicycle traffic
  - Heavy traffic with frequent lane changes
  - Bad weather
  - Roads with many curves
  - Slippery roads

- Uneven roads
- Unpaved roads
- Roads under construction
- Non-public roads

EWA23041

## **WARNING**

- The ACC system may not be able to accurately detect the vehicle ahead in the following situations:
  - You are riding on the far side of the lane.
  - The vehicle ahead is too far to either side of the lane.
  - Riding in a meandering manner with unstable steering.
  - The vehicle is pitched backward by excess load weight so that it points upward (weighted in excess of the maximum load).
  - A vehicle in an adjacent lane is driving too close to your lane.
  - Traveling steeply uphill/downhill.
- If the ACC system loses detection of the vehicle ahead or

# Special features

detects the wrong vehicle, it may accelerate/decelerate. Especially in sharp curves or on winding roads, the system may lose detection of the vehicle ahead or detect a vehicle in another lane due to the angle of the radar cone.

4

EUA5713

## ACC system operation

### How to use the ACC system

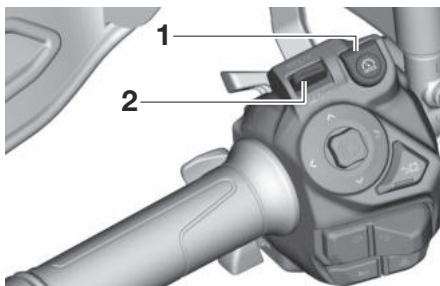

1. ACC/YVSL button “”/“MODE”
2. ACC/YVSL setting switch “RES/+”/“SET/-”

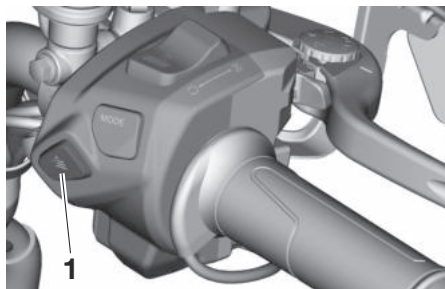

1. ACC following distance button “”

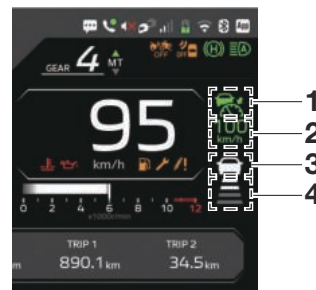

1. ACC indicator “”/“”
2. Set speed indicator
3. Vehicle detection indicator “”
4. Following distance indicator “”

1. Press the ACC/YVSL button “”/“MODE”, the ACC will be on standby and the ACC indicator will be on in black/white “”.
2. Press the ACC/YVSL setting switch “SET/-”, the ACC system will activate and the vehicle’s current speed will be set as the cruising speed. The ACC indicator will turn green “” and the set speed will be shown in the Set speed indicator “100”  
km/h”.

## TIP

- When using the ACC system, drive near the middle of the lane to facilitate accurate detection of vehicles ahead.
- If TCS (traction control system) is turned off and the stability control indicator light “SC” is on, the ACC system cannot operate.
- If the ACC malfunction indicator “” is on, have a Yamaha dealer inspect the vehicle.



1. ACC malfunction indicator icon “”

While cruising with the ACC system, press the ACC/YVSL setting switch “RES/+” to increase the set cruising speed, and press the ACC/YVSL set-

ting switch “SET/-” to decrease the set cruising speed.

## TIP

Each press of the ACC/YVSL setting switch “RES/+” / “SET/-” changes the set cruising speed by 1.0 km/h (1.0 mph). Hold the ACC/YVSL setting switch “RES/+” / “SET/-” to change it in 10 km/h (5 mph) increments.

While cruising with the ACC system, and the throttle grip is used to accelerate manually, after the throttle grip is released the vehicle will decelerate back to the set cruising speed. To set a new cruising speed after accelerating, ensure the throttle grip is still turned open and press the ACC/YVSL setting switch “SET/-”.

If the current speed is below the minimum set cruising speed, the ACC cannot be activated. The cruising speed limits in “MT” mode are as follows:

### Minimum set cruising speeds:

- 1st gear: 30 km/h (20 mi/h)
- 2nd gear: 30 km/h (20 mi/h)
- 3rd gear: 40 km/h (25 mi/h)
- 4th gear: 40 km/h (25 mi/h)
- 5th gear: 50 km/h (30 mi/h)
- 6th gear: 50 km/h (30 mi/h)

### Maximum set cruising speed:

- 160 km/h (100 mi/h)

## TIP

- In “AT” mode, the minimum set cruising speed is 30 km/h (20 mi/h).
- In “AT” mode, the Y-AMT will, if necessary, automatically shift to the appropriate gear when activating the ACC.





### Setting the following distance

While the ACC is on, and a vehicle ahead is detected, the vehicle detection indicator “” will come on. If no vehicle ahead is detected, the indicator will be off.

Press the following distance button “” to cycle through 4 levels of following distance to vehicles ahead.

# Special features

The following distance setting is indicated by the number of bars on the following distance indicator icon .

- 1 bar : Shortest (approx. 27 m at 100 km/h (0.017 mile at 62 mph))
- 2 bars : Short (approx. 33 m at 100 km/h (0.021 mile at 62 mph))
- 3 bars : Long (approx. 44 m at 100 km/h (0.027 mile at 62 mph))
- 4 bars : Longest (approx. 55 m at 100 km/h (0.034 mile at 62 mph))

## TIP



- Actual following distance for each setting varies by vehicle speed (following distance increases with speed).
- When the ACC is turned off and then restarted, the previous following distance setting will be kept.

## Deactivating / Turning off the ACC system

While cruising with the ACC, do any of the following to stop cruising and return to standby:

- Turn the throttle grip forward, past the fully closed position.

- Apply the front or rear brake.

To turn off the ACC system, press the ACC/YVSL button . When ACC is off, the ACC indicator  and the Set speed indicator will be off.

## How to use the resume function

To reactivate and start cruising again from standby, press the ACC/YVSL setting switch “RES/+”. The vehicle speed will return to the previous set cruising speed and the ACC indicator will turn green .

EWA22400

## WARNING

**If the previously set cruising speed is too fast for the current riding conditions, it is dangerous to use the resume function.**

## TIP

Turning off the ACC system will erase the previous set cruising speed. The resume function cannot be used until a new cruising speed is set.

## Automatic deactivation / turning off ACC system

While cruising with the ACC, any of the following will cause the ACC to automatically deactivate and return to standby:



- ABS or TCS engage.
- vehicle speed exceeds 180 km/h (110 mi/h) while accelerating manually with the throttle grip.
- vehicle speed falls below the following thresholds:

1st gear: 25 km/h (17 mi/h)  
2nd gear: 25 km/h (17 mi/h)  
3rd gear: 35 km/h (22 mi/h)  
4th gear: 35 km/h (22 mi/h)  
5th gear: 45 km/h (27 mi/h)  
6th gear: 45 km/h (27 mi/h)

## TIP

In “AT” mode, the minimum vehicle speed threshold for deactivation is 25 km/h (17 mi/h).

Any of the following will cause the ACC to automatically turn off:

- Stop/Run/Start switch  is set to .
- Engine is stopped.

- Side stand is lowered.

If the ACC turns off due to any of the above, the ACC indicator “” and Set speed indicator “100<sup>km/h</sup>” will flash for 4 seconds and turn off.

EWA22410

## WARNING

- In case the ACC system is deactivated or turned off, the driver must be prepared to steer, accelerate, brake, and shift gears at any time.
- If the ACC system is automatically deactivated or turned off, stop the vehicle and then check your surroundings and the road surface conditions to ensure that the vehicle is suitable for riding.

## TIP

When traveling uphill or downhill, the ACC may, in some cases, fail to maintain the set cruising speed.

- When traveling uphill, the actual vehicle speed may be less than the set cruising speed. In this case, use the throttle to accelerate to the required speed.

- When traveling downhill, the actual vehicle speed may be higher than the set cruising speed. To reduce speed, either shift to a lower gear or use the brakes.

EWA22431

## WARNING

While cruising with the ACC, the front and rear brakes are electronically controlled for deceleration. Continuous downhill riding may cause the brakes to overheat and reduce braking performance. When riding downhill, shift to a lower gear and use engine braking as much as possible.

## Passing assist

While cruising with the ACC and a vehicle ahead is detected, press the turn signal switch “” in the direction of the passing lane and the ACC will accelerate the vehicle in order to assist with overtaking.

## TIP

If the following distance is too short, the vehicle will not accelerate even if passing assist is used.

- If the passing assist is used but the vehicle does not change direction to overtake quickly, the vehicle will stop accelerating and return to the original following distance.
- If the passing assist is used repeatedly without changing direction to overtake, the acceleration will weaken or stop entirely. Passing assist can be used again if the vehicle changes lanes or the vehicle ahead leaves detection.
- Passing assist only operates when signaling and turning in the direction of the overtaking lane. The direction of the overtaking lane (left or right), is determined by your country’s traffic laws. When entering another country where the overtaking lane is opposite, the system must analyze riding data and adjust. When this happens, the passing assist will not operate

# Special features

for some time until the system can adjust itself.

## Other functions operated by the ACC system

The ACC system also assists the rider with the following functions:

### Cornering assist function

While cruising with the ACC and a vehicle ahead is detected while cornering, ACC detects lean angle and limits sudden acceleration in order to maintain stability.

### Electronically controlled suspension and brake coordination

While cruising with the ACC, the engine brake, front brake and then rear brake are applied in sequence to decelerate the vehicle and maintain following distance. At the same time, the electronically controlled suspension system adjusts the damping force to reduce excessive forward pitch.

## Yamaha variable speed limiter (YVSL)

EUAJ6622

This model is equipped with the Yamaha variable speed limiter (YVSL) which limits the vehicle to a maximum speed set by the rider.

The YVSL can be set to any speed limit between 50 km/h (31 mi/h) and 180 km/h (112 mi/h). When the set speed limit is reached, the engine output is restricted to keep the vehicle from exceeding set speed limit without throttle control.

EWA22900

### **WARNING**

- **Improper use of the YVSL system may result in loss of control, which could lead to an accident. Do not activate the YVSL system in heavy traffic, poor weather conditions, or among winding, slippery, hilly, rough or gravel roads.**
- **The YVSL system may not be able to maintain the set speed limit when traveling uphill, downhill, or under sudden acceleration.**



- **Confirm whether the YVSL system is ON/OFF before use.**
- **To prevent accidentally activating the YVSL system, turn it off when not in use. Make sure that the YVSL display is off.**



1. YVSL indicator
2. Set speed indicator



### TIP



- In some cases, the YVSL system may not be able to maintain the set speed limit when the vehicle is traveling downhill, under sudden acceleration, or immediately following a gear shift.
  - If the vehicle exceeds the set speed limit by 5 km/h (3 mi/h) or more for more than 3 seconds,

the YVSL indicator  and the set speed indicator  will flash until the vehicle speed decreases to within the limit.

- If the vehicle traveling speed becomes higher than the set speed limit, apply the brakes.
- When the YVSL disengages, engine output is gradually derestricted to ensure a smooth transition to full rider control of the throttle.
- In “AT” mode with YVSL active, if the throttle grip is turned too much after reaching the set speed limit, the Y-AMT will remain in a lower gear. To shift to a higher gear, slightly turn the throttle grip in the deceleration direction until the Y-AMT upshifts.



## Activating and setting the YVSL

1. Press the ACC/YVSL button  located on the left handlebar. The ACC indicator  will come on.
2. Press the ACC/YVSL button  a second time to switch to the YVSL standby mode. The YVSL indica-

tor  and the set speed indicator  will come on.

3. Push the “SET-” side of the ACC/YVSL setting switch to activate the YVSL. The YVSL indicator  will come on and the speed limit will be set to your current traveling speed which will be shown on the set speed indicator.

## TIP

- Pressing the ACC/YVSL button  while the ACC system is active and the ACC indicator  is on will also switch to the YVSL standby mode.
- The ACC system and the YVSL system cannot both be active at the same time.

## Adjusting the speed limit

While the YVSL is activated, push the “RES+” side of the ACC/YVSL setting switch to increase the set speed limit or the “SET-” side to decrease the set speed limit.



## TIP

Pushing the ACC/YVSL setting switch once will change the set speed in increments of approximately 1.0 km/h (1.0 mi/h). Holding the setting switch will change the set speed in increments of 10 km/h (10 mi/h).

## Deactivating the YVSL

When the YVSL is disengaged, engine output is gradually derestricted to ensure a smooth transition to full rider control of the throttle.

Perform one of the following operations to deactivate the YVSL:

- Turn the throttle grip past the closed position in the deceleration direction. The YVSL indicator  will turn to  will go off and the system will return to standby mode.

# Special features

4

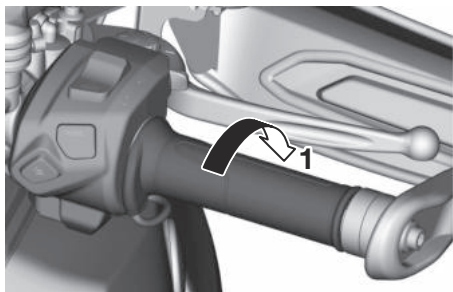

1. Deceleration direction

- Press the ACC/YVSL button “” located on the left handlebar. The YVSL indicator and set speed indicator will go off.

## Using the resume function

Push the “RES+” side of the ACC/YVSL setting switch to reactivate the YVSL when in standby mode. The speed limit will return to the previously set speed limit.

EWA21210



**WARNING**

**It is dangerous to use the resume function when the previously set speed limit is too low for current conditions.**

## TIP

Press the ACC/YVSL button “” while the YVSL system is operating will turn the system off completely and erase the previously set speed limit. You will not be able to use the resume function until a new speed limit has been set.

EAU5722

## Brake system

This vehicle is equipped with an integrated anti-lock brake system (ABS) and unified brake system (UBS).

### How to operate the brakes:

Operate the brake lever and brake pedal the same as you would conventional brakes. If wheel slip is detected while braking, ABS will activate and a pulsating sensation may be felt at the brake lever or brake pedal. Continue to apply the brakes and let the ABS work. Do not pump the brakes as this will reduce braking effectiveness.

## TIP

The ABS performs a self-diagnostic test when the vehicle starts off and reaches a speed of 5 km/h (3 mi/h). During this test, a clicking noise may be audible from the hydraulic control unit, and some vibration may be felt at the brake lever or pedal, but this is normal.

## Anti-lock brake system (ABS)

The anti-lock brake system (ABS) acts on the front and rear brakes independently.

EWA16051

### **WARNING**

Always keep a sufficient distance from the vehicle ahead to match the riding speed even with ABS.

- The ABS performs best with long braking distances.
- On certain surfaces, such as rough or gravel roads, the braking distance may be longer with the ABS than without.

ECA20100

### **NOTICE**

Be careful not to damage the wheel sensor or wheel sensor rotor; otherwise, improper performance of the ABS will result.

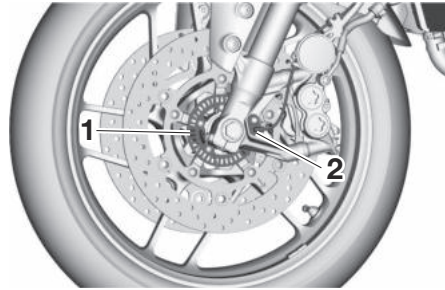

1. Front wheel sensor rotor
2. Front wheel sensor

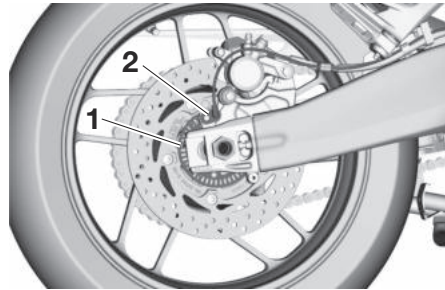

1. Rear wheel sensor rotor
2. Rear wheel sensor

## Unified brake system (UBS)

The unified brake system (UBS) is a front-rear linked braking system. The basics of using brakes on a motorcycle

or scooter is to use both the front and rear brakes at the same time. With UBS active, operating either the front or rear brake also suitably distributes braking power to the other brake. The UBS also automatically adjusts braking force while cornering.

### **TIP**

- If BC is set to OFF, UBS does not operate (see page 4-26).
- UBS is active only when the brakes are applied manually by the rider at speeds above 30 km/h (18 mi/h).
- Depending on the rider's brake operation, UBS may continue to operate even below 30 km/h (18 mi/h).
- UBS will not work if the rider does not operate the brakes.
- When cornering, UBS may not work if your lean angle is too great.
- When UBS is activated, there may be a change in the feel of the brake lever or pedal operation, but this is not a malfunction.

# Special features

## Radar-linked UBS

The UBS integrates data from the millimeter-wave radar unit to adjust braking force based on the detected distance to the vehicle ahead.

### TIP

- Radar-linked UBS will not work if the rider does not operate the brakes manually.
- If the FCW setting is turned to “OFF” in the menu system, the radar-linked UBS will also be disabled.
- Even if BC is set to OFF, the radar linked UBS will continue to operate if FCW is set to “Near” or “Normal”.

### WARNING

EWA22600

The UBS and radar-linked UBS are not safety or collision avoidance systems. The responsibility for safety lies with the rider. Riders shall always maintain awareness of their surroundings and road conditions, and actively operate the vehicle to decelerate and accelerate safely.

If strong braking force is applied by the radar-linked UBS, a rider intervention request will be displayed. When the display screen changes to show the rider intervention request, immediately take full control of the vehicle and assess the situation.

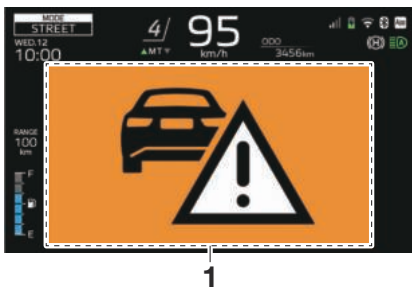

1. Rider intervention request

### WARNING

EWA23020

- Depending on the surrounding environment and traffic conditions, the radar-linked UBS may not work or decelerate unexpectedly. The rider must always be prepared to steer, accelerate, brake, and shift gears at any time.

- The radar-linked UBS may not be able to accurately detect the movement of vehicles ahead depending on the situational conditions. Apply brakes manually, in the following situations:
  - Another vehicle suddenly cuts in front of you
  - The vehicle ahead suddenly brakes
  - The difference in speed with the vehicle ahead is very large

EAUJA5872

## YRC (Yamaha Ride Control)

YRC is a system that incorporates numerous sensors and controls to support an improved riding experience. The vehicle senses and can react to forces along the longitudinal (front-to-back), lateral (left-to-right), and vertical (up-and-down) axes. Lean angle and G-force accelerations are also detected. This information is processed multiple times a second and the related physical systems are automatically adjusted as necessary. The following functions represent individual YRC items which can be turned on/off or adjusted to suit various riders and riding conditions. For setting details, see page 6-33.

EWA18221



**WARNING**

**The Yamaha Ride Control (YRC) system is not a substitute for the use of proper riding techniques or the expertise of the operator. This system cannot prevent loss of control caused by rider errors such as traveling faster than warranted by road and traffic conditions, including loss**

**of traction due to excessive speed when entering turns, when accelerating hard at a sharp lean angle, or while braking, and it cannot prevent front wheel slip or front wheel lift. As with any motorcycle, always ride within in your limits, be aware of surrounding conditions, and ride appropriately for those conditions. Become thoroughly familiar with the way the motorcycle handles with various YRC settings before attempting more advanced maneuvers.**

## SC (Stability control system)

SC consists of TCS (traction control system), SCS (slide control system), LIF (lift control system) and BSR (back slip regulator). These can be independently adjusted in the menu system (see page 6-33), or turned on/off all together by turning off TCS in the menu system (see page 6-38).

When any of the SC systems engage while riding, the stability control indicator light “SC” will flash (see page 6-6).

## PWR (Power delivery mode)

PWR consists of four different control maps which regulate throttle valve opening in relation to the degree of throttle grip operation, thus providing you with a selection of modes to fit your preferences and the riding environment.

- Level 1 - Sporty engine response.
- Level 2 - Moderate engine response.
- Level 3 - Mild engine response.
- Level 4 - Rainy days or whenever less engine power is desirable.

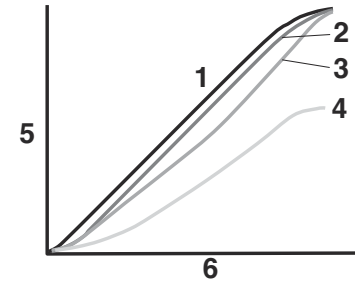

1. PWR 1
2. PWR 2
3. PWR 3
4. PWR 4
5. Throttle valve opening
6. Throttle grip operation

# Special features

## TCS (Traction control system)

TCS helps maintain traction when accelerating. If sensors detect that the rear wheel is starting to slip (uncontrolled spinning), TCS assists by regulating engine power as needed until traction is restored.

TCS automatically adjusts according to the vehicle's lean angle. To maximize acceleration, when the vehicle is upright a less amount of traction control is applied. When cornering, a greater amount of traction control is applied.

TCS has multiple setting levels. The higher the setting level, the greater the amount of system intervention.

Level 1 - Suitable for more sporty riding.

Level 2 - Suitable for street riding.

Level 3 - Suitable for riding on wet or slippery surfaces.



Traction control system

### TIP

- TCS may engage when the vehicle travels over a bump.
- You may notice slight changes in engine and exhaust sounds when TCS or other YRC systems engage.
- When the main switch is turned on, TCS automatically turns on. TCS can be turned on/off manually only when the main switch is turned on and the vehicle is stopped.
- Turn TCS off to help free the rear wheel if the vehicle gets stuck in mud, sand, or other soft surfaces.

EWA15433

### **!** WARNING

The traction control system is not a substitute for riding appropriately for the conditions. Traction control cannot prevent loss of traction due to excessive speed when entering turns, when accelerating hard at a sharp lean angle, or while braking, and cannot prevent front wheel slipping. As with any vehicle, approach surfaces that may be slippery with caution and avoid especially slippery surfaces.

ECA16801

### NOTICE

Use only the specified tires. (See page 9-14.) Using different sized tires will prevent the traction control system from controlling tire rotation accurately.

## SCS (Slide control system)

SCS regulates engine power output when a sideward slide is detected in the rear wheel. It adjusts power output based on the lean angle of the vehicle. This system supports TCS (traction

control system) to contribute to a smoother ride.

SCS has multiple setting levels. The higher the setting level, the greater the amount of system intervention to strongly reduce lateral wheel slippage.

Level 1 - Suitable for more sporty riding.

Level 2 - Suitable for street riding.

Level 3 - Suitable for riding on wet or slippery surfaces.

### LIF (Lift control system)

LIF reduces the rate at which the front wheel will continue to rise during extreme acceleration, such as during starts or out-of-corner exits. When front-wheel lift is detected, engine power is regulated to slow front-wheel lift while still providing good acceleration.

LIF can be set to 1, 2, and 3.

The higher the setting level, the greater the amount of system intervention to reduce wheel lift.

Level 1 - Least lift control. Suitable for more sporty riding.

Level 2 - More lift control. Suitable for sporty riding.

Level 3 - Most lift control. Suitable for street riding.

### EBM (Engine brake management)

EBM reduces engine torque when decelerating. The fuel injection, ignition timing, and electronic throttle valve are electronically adjusted by the ECU.

EBM can be set to 1 or 2.

The higher the setting level, the greater the amount of system intervention to reduce engine braking.

Level 1 - Least engine brake management suitable for more sporty riding.

Level 2 - More engine brake management. Suitable for street riding.

### WARNING

**Make sure the engine has sufficiently slowed before shifting to a lower gear. Engaging a lower gear when the engine speed is too high could make the rear wheel lose traction. This could cause loss of control, an accident and injury. It could also cause engine or drivetrain damage.**

### SUS (Electronically controlled suspension damping system)

SUS is an electronically controlled suspension damping system, which can automatically adjust the suspension damping force to suit the riding situation. The system has 4 control maps (A-1, A-2, C-1, C-2).

EWA21170

### WARNING

**Do not change the suspension mode while the vehicle is moving.**

A-1: Preset automatic sport map, with increased damping force.

A-2: Preset automatic comfort map, with softened damping force.

C-1/C-2: User customizable control maps.

The C-1/C-2 maps can be customized in the Yamaha Motorcycle Connect app. There are two types of map; automatic and non-automatic.

Automatic maps allow customization for adapting the suspension automatically to various driving situations.

Non-Automatic maps have standard settings for front and rear rebound and compression damping force.

# Special features

---

## BC (Brake control system)

BC regulates hydraulic brake pressure for the front and rear wheels when the brakes are applied. This system has two settings:

- OFF: Only the standard ABS (anti-lock brake system), which adjusts brake pressure based on vehicle speed and wheel speed data. The standard ABS (anti-lock brake system) designed to engage and maximize braking when the vehicle is upright.
- ON: ABS (Anti-lock brake system) and cornering assist braking are both active. In addition to the standard ABS, it suppresses the increase in brake pressure when unavoidable abrupt braking occurs during cornering, making the vehicle's recovery to upright position more gradual. Also, additional data from the IMU regulates applied brake power depending on lean angle in order to increase the feeling of stability and to suppress wheel lock.

See page 4-20 for more information on the Brake System.

## TIP

- For skilled riders or when track riding, a variety of conditions may cause BC to brake faster than expected for a desired cornering speed or intended cornering line.
- If BC is set to OFF, UBS does not operate.

EWA22532

## WARNING

- **Even with BC ON, strong braking during cornering may result in wheel slippage and loss of balance. Please decelerate sufficiently before entering corners.**
- **Do not use BC on roads other than public roads, as BC may not operate properly and an accident may result.**

## BSR (Back slip regulator)

BSR helps maintain traction when decelerating and/or downshifting in low traction conditions. If sensors detect that the rear wheel is starting to slip or lock, BSR assists by regulating engine

power as needed until traction is restored.

## TIP

- BSR may engage when the vehicle travels over a bump.
- You may notice slight changes in engine and exhaust sounds when BSR or other YRC systems engage.
- For skilled riders or those engaging in track riding, various conditions may lead BSR to influence the vehicle's behavior differently from what the rider anticipates.

EWA22700

## WARNING

**The back slip regulator is not a substitute for riding appropriately for the conditions. The back slip regulator cannot prevent loss of traction due to excessive speed when entering turns or braking and cannot prevent front wheel slippage. As with any vehicle, approach surfaces that may be slippery with caution and avoid especially slippery surfaces.**

## NOTICE

Use only the specified tires. (See page 9-14.) Using different sized tires will prevent the back slip regulator from controlling tire rotation accurately.

ECA28580

## Y-AMT (Yamaha-Automated Manual Transmission)

EUA2704

This vehicle is equipped with a sequential 6-speed Yamaha-Automated Manual Transmission (Y-AMT), enabling the vehicle to shift gears without the operation of a clutch lever or shift pedal.

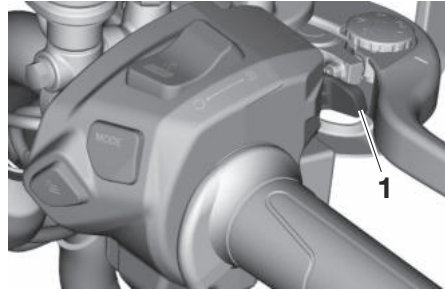

1. Y-AMT switch "AT/MT"

There are two Y-AMT modes:

"AT" - Automatic gearshifts.

"MT" - Gearshifts using the shift lever on the handlebar.

The Y-AMT switch "AT/MT" is used to change between "AT" and "MT" modes. (See page 6-3.)

The currently selected Y-AMT mode is displayed on the Y-AMT indicator "AT"/"MT". (See page 6-16.)

There are five YRC modes for "MT" and two for "AT". (See page 6-33.)

When the Y-AMT switch "AT/MT" is used to change between "AT" and "MT", the YRC mode will be changed accordingly.

## TIP

When changing from "AT" to "MT", the YRC mode will be "STREET". When changing from "MT" to "AT" the YRC mode will be the previous setting.

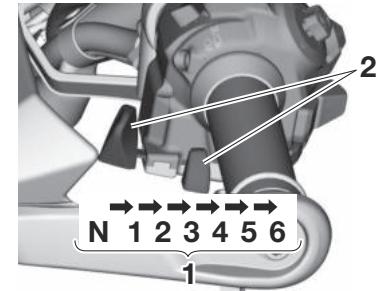

1. Gear positions
2. Shift lever

The shift lever is used to shift gears in both "AT" and "MT" modes.

Y-AMT automatically downshifts to 1st gear when the vehicle is stopped, even

## Special features

in “MT” mode. When stopped in 1st gear the clutch is automatically disengaged until the throttle grip is turned, this allows the engine to idle at a stop without shifting into neutral. After the engine is turned off, the transmission will automatically engage the clutch so the vehicle cannot roll freely.

To keep the vehicle in neutral with the vehicle power off, downshift to neutral and then turn off the main switch.

See page 8-3 for more information on shifting.

### TIP

- When the shift lever is used to manually change gears in “AT” mode, “AT” mode will resume after the gearshift is complete.
- Y-AMT prevents manual gear shifts at too high/low engine speeds.
- When the vehicle power is turned on in gear, the gears cannot be shifted until either the brake lever or pedal is pressed.
- In “MT” mode, Y-AMT automatically downshifts when engine speed is too low.

EWA22740

### WARNING

**Do not push the vehicle while the engine is running. Unintentional rotation of the throttle grip and/or accidental pressing of the shift lever may result in accidents.**

EWA22750

### WARNING

**If you suspect any damage or wear to the Y-AMT components, have a Yamaha dealer inspect the vehicle. The Y-AMT contains sensitive components. Improper maintenance could cause an accident.**

EAU1773

## ESS (emergency stop signaling) system

When sudden deceleration occurs this system automatically activates to cause all turn signal lights to flash rapidly.

This provides additional warning to surrounding vehicles that your vehicle is decelerating rapidly.

The ESS system then deactivates under the following conditions:

- When the brakes are released.
- When sudden deceleration is no longer detected.

EWA22680

### WARNING

**The ESS system is not a collision prevention system. Avoid unnecessary hard braking and prioritize safe driving.**

### TIP

- The ESS system only activates when it detects sudden braking while the vehicle is traveling at speeds of 50 km/h (31 mi/h) or higher.

- ESS does not activate when the hazard lights are already activated.
- If the ESS is activated while one of the turn signal lights is already flashing, the ESS takes priority, causing all turn signals to flash rapidly.
- ESS does not operate when the ABS indicator light is on.

## Pre-ride Suspension Damp- ing system

EUA4852

The Pre-ride Suspension Damping system automatically reduces suspension damping to assist the rider in mounting and maneuvering the vehicle when parked/parking.

The system will activate for 30 seconds when:

- the vehicle power is switched on.
- the engine is stopped with the engine stop switch while the main switch remains ON.

After 30 seconds or when the engine is turned on, the system deactivates and returns to the selected suspension settings.

### TIP

The pre-ride suspension damping system does not operate when the engine is running.

ECA28820

### NOTICE

**Do not repeatedly turn the vehicle power ON/OFF without running the engine, as the repeated activation of**

**the pre-ride suspension damping system will drain the battery.**

# Special features

4

## VHC (Vehicle hold control)

EUAU5734

The Vehicle Hold Control (VHC) system assists with holding the brakes while stopped, helping to prevent unintentional movement and stabilize the vehicle.

EWA22960





### WARNING

**Always stay aware of your surroundings and traffic and conditions and manually operate the brakes as necessary to maintain control of the vehicle.**

- **Vehicle Hold Control (VHC) is not a parking brake; it is designed to assist the rider with braking. It does not guarantee that the vehicle will remain stationary under all conditions.**
- **When stopped on a steep slope, the vehicle may still move backward or forward even with VHC activated.**

VHC has three settings which can be changed in the menu system. (see page 6-39.)

- “Standard”: When hard pressure is applied to either the brake lever or brake pedal while the vehicle is stopped, the system keeps the brakes engaged until the VHC is deactivated.
- “Advanced”: Same as “Standard” mode but additionally: on inclines, the system automatically keeps the brakes engaged after the vehicle is stopped.
- “OFF”: The system is disabled and the VHC OFF indicator “

When the VHC is active (keeping the brakes engaged) the VHC indicator “

The VHC can be active if all the following conditions are true:

- VHC is set to “Advanced” or “Standard”.
- The vehicle is stopped.
- Either the front or rear brake is applied.
- The sidestand is up.
- The ABS warning light is off.

If the VHC OFF indicator “

### TIP

If the vehicle has not yet been ridden at a speed of more than 5 km/h (3 mi/h), the ABS warning light will be on and the VHC will not be active.

To deactivate VHC and release the brakes:

- Press the front brake lever twice quickly.
- Turn the throttle grip and start the vehicle off.

When the VHC deactivates, the VHC indicator “

### TIP

VHC automatically deactivates after 5 minutes. The VHC indicator “

4-30

## TPMS (Tire pressure monitoring system)

EUA5880

This model is equipped with a TPMS. If low tire-pressure is detected, the tire pressure warning light “” will come on. Each of the front and rear tire pressure values can be selected on the vehicle information display (See page 6-11.) or displayed on the vehicle status display (See page 6-13.).

EWA22850

### **WARNING**

The tire pressure displayed on the vehicle information display is intended for reference only, because it is affected by the temperature of tires while riding. For the pre-operation checks, always check and adjust the air pressure using an air pressure gauge on cold tires.

### **TIP**

- If a sensor battery is discharged or if a malfunction is detected, the tire pressure warning light “” will flash.

- The sensor batteries should be replaced every 4 years, depending on usage conditions.
- When the vehicle power is turned on, the TPMS vehicle information display will show “---” until the vehicle starts moving.

ECA28720

### **NOTICE**

- **Use only the specified tires. Use of other tires may affect the accuracy of the TPMS and cause damage to the sensors and/or batteries.**
- **Tire replacement should only be done by a Yamaha dealer; otherwise, it may affect the accuracy of the TPMS and cause damage to the sensors and/or batteries.**
- **Do not charge or reuse the TPMS batteries.**
- **Do not disassemble and/or burn the batteries.**
- **Dispose of the batteries properly according to local law/regulation.**

## Smart key system

EUA2502

The smart key system enables you to operate the vehicle without using a mechanical key.

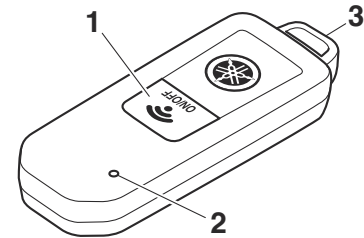

1. “ON/OFF” switch
2. Smart key indicator light
3. Mechanical key

EWA14704

### **WARNING**

- **Keep implanted pacemakers or cardiac defibrillators, as well as other electric medical devices away from the vehicle mounted antenna (see illustration).**
- **Radio waves transmitted by the antenna may affect the operation of such devices when close by.**

# Special features

- If you have an electric medical device, consult a doctor or the device manufacturer before using this vehicle.

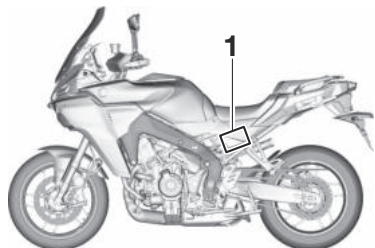

1. Vehicle mounted antenna

ECA24080

## NOTICE

The smart key system uses weak radio waves. The smart key system may not work in the following situations.

- The smart key is placed in a location exposed to strong radio waves or other electromagnetic noise
- There are facilities nearby that are emitting strong radio waves (TV or radio towers, power

plants, broadcasting stations, airports, etc.)

- You are carrying or using communication equipment such as radios or mobile phones in close proximity of the smart key
- The smart key is in contact with or covered by a metallic object
- Other vehicles equipped with a smart key system are nearby

In such situations, move the smart key to another location and perform the operation again. If it still does not work, operate the vehicle in emergency mode. (See page 9-35.)

## TIP

To preserve vehicle battery power, the smart key system turns off approximately 9 days after the vehicle was last used. In this situation, simply push the main switch knob to turn the smart key system back on.

EAUA2511

## Operating range of the smart key system

The approximate operating range of the smart key system is shown below.

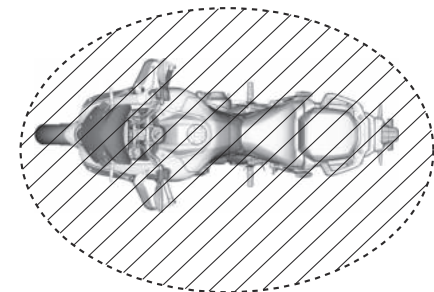
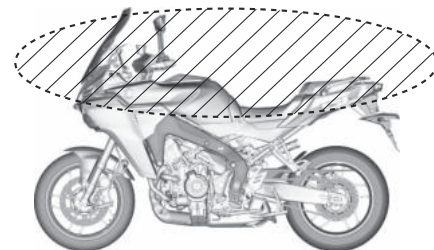

If the smart key is turned off, the vehicle will not recognize the smart key even if it is within operating range. If the smart key battery is discharged, the smart key system may not work or its

operating range may become very short.

## TIP

- Do not place the smart key in a storage compartment.
- Always carry the smart key with you.
- Turn the smart key off when leaving the vehicle.

## Handling of the smart key and mechanical key

EUA2524

Included with the vehicle is one smart key (with a built-in mechanical key) and one spare mechanical key with an identification card. Keep the spare mechanical key and card separate from the smart key. Should you lose or damage the smart key, or when its battery is discharged, the mechanical key will serve as a back up. The smart key system identification number can be manually input, and then the vehicle can be operated. (See page 9-35.) We recommend that you **note down the identification number in case of emergency.**

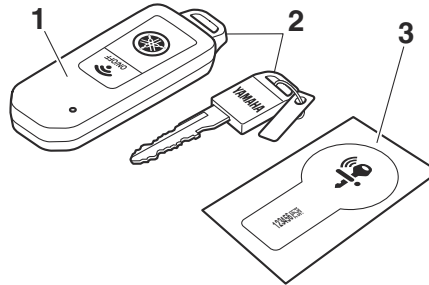

1. Smart key

2. Mechanical key
3. Identification number card

If the smart key and identification number card are both lost or damaged, and there is no record of the identification number, the entire smart key system will need to be replaced.

ECA21573

## NOTICE

**The smart key has precision electronic components. Observe the following precautions to prevent possible malfunction or damage.**

- Do not place or store the smart key in a storage compartment. The smart key may be damaged from road vibrations or excessive heat.
- Do not drop, bend, or subject the smart key to strong impacts.
- Do not submerge the smart key in water or other liquids.
- Do not place heavy items or excessive stress on the smart key.
- Do not leave the smart key in a place exposed to direct sunlight, high temperature or high humidity.

## Special features

---

- Do not grind or attempt to modify the smart key.
- Keep the smart key away from strong magnetic fields and magnetic objects such as key holders, TVs, and computers.
- Keep the smart key away from electric medical equipment.
- Do not allow oils, polishing agents, fuel, or any strong chemicals to come in contact with the smart key. The smart key body may become discolored or cracked.

---

### TIP

- The smart key battery life is approximately two years, but this may vary according to operating conditions.
- The smart key battery may become discharged even if it is away from the vehicle and not being used.
- If the smart key continually receives radio waves, the smart key battery will discharge quickly. (For example, when placed in the vicinity of electrical products such as televisions, radios, or computers.)

ity of electrical products such as televisions, radios, or computers.)



1. Smart key system indicator light “”

Replace the smart key battery when the smart key system indicator light flashes for about 20 seconds when the vehicle is first powered on, or when the smart key indicator light does not come on when the “ON/OFF” switch is pushed. (See page 4-35.) After changing the smart key battery, if the smart key system still does not operate, have a Yamaha dealer check the vehicle.

---

### TIP

- You can register up to six smart keys for the same vehicle. See a

Yamaha dealer regarding spare smart keys.

- If a smart key is lost, contact a Yamaha dealer immediately to prevent the vehicle from being stolen.
-

## Smart key

EAUJA2531

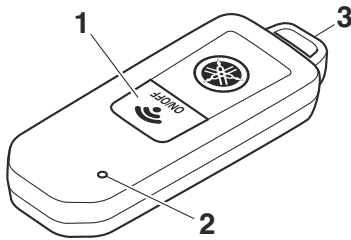

1. “ON/OFF” switch
2. Smart key indicator light
3. Mechanical key

When the smart key is turned on and brought within range, the smart key system allows you to operate the vehicle without inserting a mechanical key. If the smart key is turned off, the vehicle cannot be operated even if the smart key is within operating range of the vehicle.

The current status of the key can be checked by briefly pressing the “ON/OFF” switch.

- Short flash: the key is on
- Long flash: the key is off

## To turn the smart key on or off

To turn the smart key on or off, press the “ON/OFF” switch for one second. The smart key indicator light will flash. If the key does a short flash, the key is on. If the key does a long flash, the key is off.

## To use the mechanical key

Pull out the mechanical key from the smart key body. After using the mechanical key, insert it back into the smart key.

## Replacing the smart key battery

EAUJA2543

Replace the battery in the following situations.

- The smart key system indicator light flashes for a few seconds when the power of the vehicle is turned on.
- When the smart key indicator light does not come on when the “ON/OFF” switch is pushed.



1. Smart key system indicator light “”

EWA22830

## WARNING

This battery contains combustible materials such as lithium metal and organic electrolyte. The following

# Special features

4

cautions should be followed in order to use this battery safely:

- Do not short circuit the battery
- Do not charge the battery
- Do not soak the battery in water
- Do not deform or damage the battery
- Do not modify the battery in any way

## To replace the smart key battery

1. Gently pry open the smart key case as shown. Otherwise, have a Yamaha dealer replace the battery.

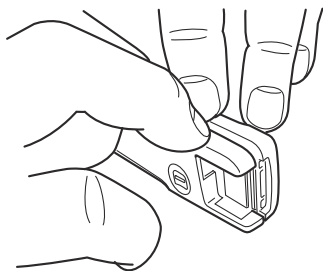

2. Remove the battery cover and O-ring.

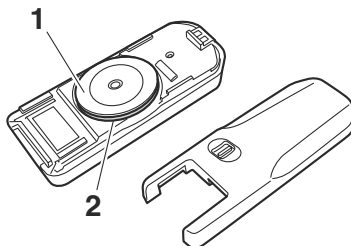

1. Battery cover
2. O-ring
3. Remove the battery.

### TIP

Dispose of the removed battery in accordance with local regulations.

4. Note the polarity of the battery and install it with the positive “+” side facing upwards as shown.

**Specified battery:**  
CR2025

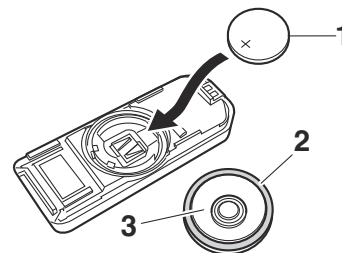

1. Battery
2. O-ring
3. Battery cover
5. Install the O-ring and battery cover.
6. Gently snap the smart key case closed.

ECA24011

### NOTICE

- Do not apply excessive force to the smart key when replacing the battery.
- Do not use a screwdriver or other hard object to force open the key.
- Take precautions to prevent the waterproof seal from being

damaged or contaminated by dirt.

- Do not touch the internal circuits and terminals. This may cause malfunctions.
- Make sure the battery is installed correctly. Confirm the direction of the positive “+” side of the battery.

## WARNING

EWA20632

**Danger of explosion if battery is incorrectly replaced**

- Replace only with the same or equivalent type.
- Please check and obey all local laws and regulations for the disposal of batteries or accumulations.
- Never dispose of battery in fire or mechanical crushing or cutting.
- If battery is incorrectly discarded or heated to high temperature (100 °C (212 °F) or higher), gas may be generated inside battery, causing electrolyte leak, internal short circuit, heat

generation, explosion and violent flaring.

Do not expose Hand Unit to excessive heat such as sunshine, fire or the like.

Do not ingest the battery, Chemical Burn Hazard

- This product contains a coin/button cell battery. If the coin/button cell battery is swallowed or placed inside any part of the body, it can cause severe internal burns in just 2 hours and can lead to death. Keep new and used batteries away from children.
- If the battery compartment does not close securely, stop using the product and keep it away from children.
- If you think batteries might have been swallowed or placed inside any part of the body, seek immediate medical action.

## Main switch

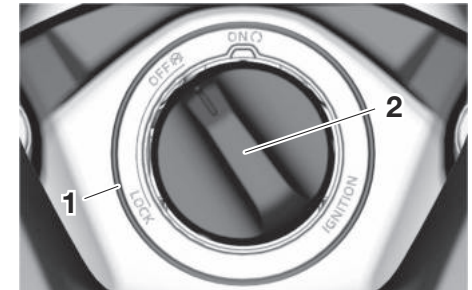

1. Main switch
2. Main switch knob



1. Smart key system indicator light “”

The main switch is used to turn the vehicle power on/off and lock/unlock the steering. After pushing the main switch knob and confirmation with the smart

# Special features

key has taken place, the main switch can be turned while the smart key system indicator light is on (approximately 4 seconds).

EWA22722

## WARNING

**Never turn the main switch to “OFF” or “LOCK” while the vehicle is moving. Otherwise the electrical systems will be switched off, which may result in loss of control or an accident.**

## TIP

- Do not push the main switch knob repeatedly or turn the main switch back and forth beyond normal use. Otherwise, to protect the main switch from damage, the smart key system will temporarily disable and the smart key system indicator light will flash. If this occurs, wait until the indicator light stops flashing before operating the main switch again.
- In order to conserve battery power, if the main switch remains on with the engine off for a few seconds then an alarm will beep to re-

mind the user to turn off the main switch.

The main switch positions are described below.

## ON

EUAJ2563

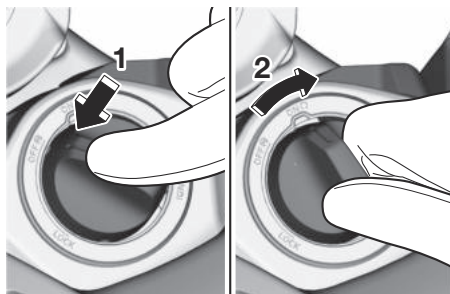

1. Push.
2. Turn.

All electrical circuits are supplied with power, and the engine can be started.

## To turn the vehicle power on

1. Turn the smart key on and bring it within operating range.
2. Push the main switch knob and the smart key indicator light will come on for approximately 4 seconds.

3. While the smart key system indicator light is on, turn the main switch knob to “ON”. All of the turn signal lights will flash twice and the vehicle power will turn on.

## TIP

- If the vehicle battery voltage is low, the turn signal lights will not flash.
- See “Emergency mode” on page 9-35 for information on turning the vehicle power on without the smart key.

EUAJ2583

## OFF



1. Turn.

All electrical systems are off.

## To turn the vehicle power off

1. With the smart key turned on and within operating range, turn the main switch knob to “OFF”.
2. The turn signal lights flash once and the vehicle power turns off.

## TIP

When the main switch is turned to “OFF” but the smart key cannot be confirmed (the smart key is either outside operation range or has been turned off), the beeper will sound for 3 seconds and the smart key system indicator light will flash for 30 seconds.

- During this 30 seconds, the main switch can be freely operated.
- After 30 seconds, the vehicle power will turn off automatically.
- To turn the vehicle power off immediately, push the main switch knob four times within 2 seconds.

## **LOCK**

EAU2590

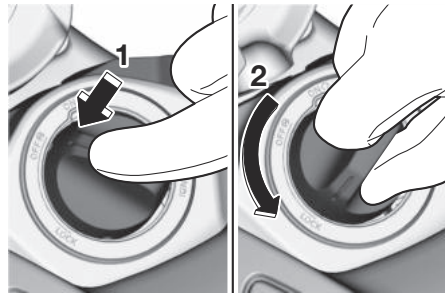

1. Push.
2. Push and turn.

The steering is locked and all electrical systems are off.

## To lock the steering

1. Turn the handlebar all the way to the left.
2. With the smart key turned on and within operating range, push the main switch knob.
3. While the smart key system indicator light is on, push and turn the main switch knob to “LOCK”.

## TIP

If the steering will not lock, try turning the handlebar back to the right slightly.

EWA14742

## **⚠ WARNING**

**Do not operate the steering lock while the vehicle is moving.**

4

## To unlock the steering

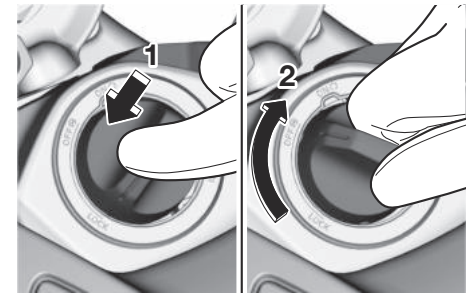

1. Push.
2. Push and turn.

1. With the smart key turned on and within operating range, push the main switch knob.
2. While the smart key system indicator light is on, push and turn the

# Special features

main switch knob to the desired position.

4

## Fuel tank cap opening and closing

EUAJA2601

### To open the fuel tank cap

1. Pull up on the fuel tank cap latch within 2 minutes of powering the vehicle off.

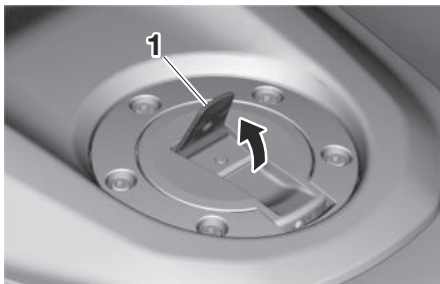

1. Fuel tank cap latch

2. Open the fuel tank cap.



1. Fuel tank cap

### TIP

- Two minutes after the vehicle is powered off, the fuel tank cap will lock. In that case, pull up the fuel tank cap latch to perform smart key system authentication and open the fuel tank cap.
- Pull up the latch again to open the fuel tank cap.

### To close the fuel tank cap

Push the fuel tank cap to the original position.

## TIP

- An alarm will beep when the power is turned on with the fuel tank cap open. The alarm will stop when the fuel tank cap is closed or 30 seconds have passed.
- After 5 consecutive operations in a short period of time, the fuel tank cap will lock and the smart key indicator will blink for 3 seconds. The lock will release 5 minutes after the last operation.

EWA21301

## **WARNING**

**Make sure that the fuel tank cap is properly closed before operating the vehicle. Leaking fuel is a fire hazard.**

---

# Smartphone Connectivity System

## Smart features (communication control unit)

EUAU44890

EWA21412

### **WARNING**

- Failure to pay attention while riding could result in death or serious injury. Always concentrate on riding by keeping your eyes and mind on the road.
- Stop the vehicle before making any settings changes.
- Changing settings while riding can distract the operator and increase the risk of an accident.
- Never take your hands off the handlebars while riding.
- Keep volume levels low enough to maintain awareness of your surroundings and ensure safety.

This vehicle is equipped with an extensive suite of smart features utilizing your smartphone, connected to the vehicle through a communication control unit (CCU) and the Yamaha Motorcycle Connect app.

- GPS navigation (requires Garmin Motorize app connected via Wi-Fi or USB) (page 5-3)
- Telephone (page 5-8)
- Audio player (page 6-21)
- Smartphone notifications (page 6-27)
- Weather information (page 6-28)
- Clock automatic update (page 6-32)
- Language settings (page 5-2)

### **TIP**

- Some features may not be available depending on your smartphone.
- Some music and SNS applications may not function properly in combination with other applications.
- Wi-Fi connectivity is not supported in some countries. In such cases, Wi-Fi related menu items are grayed out.
- The CCU takes about 30 seconds to boot after the vehicle power is turned on. “[App] Applications” and other smart features will not be available during this time and will

appear grayed out in the menu system.

- After disconnecting/reconnecting the battery, the CCU takes about 1 minute to boot.

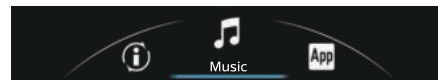

Smart features are accessed via the pop-up menu system at the bottom of the main display (see page 6-20). The menu system and all related features are controlled using the joystick/home button “

5-1

## Joystick/Home button

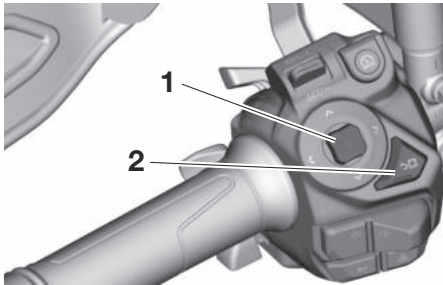

1. Joystick “✓”
2. Home button “↵”

This manual uses the following terms to describe the usage of the joystick/home button:

Short press	Briefly press the joystick or button
Long press	Press the joystick or button for 1 second

To open the pop-up menu from the main display:

- Short press the home button “↵”
- Operate the joystick left-right
- Short press “✓”

## Menu system operation:

- Operate the joystick left-right-up-down to select and adjust menu items.
- Short press “✓” to execute a selection.
- Short press the home button “↵” button to return to the previous screen.
- Long press the home button “↵” button to close the menu system.

## TIP

- When arrows “←” appear highlighting a menu item, operating the joystick in the direction of the arrows will adjust the highlighted function.
- Some menu pages have a back arrow “<”. If so, operate the joystick left to return to the previous screen.
- Some menu items have a forward arrow “>” next to them. While the item is highlighted, operate the joystick right or press “✓” to open that module.

## Yamaha Motorcycle Connect app



Yamaha Motorcycle Connect is a free app which is needed to complete the connection between the CCU and your smartphone. The app can be searched by name and downloaded from your smartphone application store.

## TIP

- Use of Yamaha Motorcycle Connect is subject to your agreement to the Yamaha Motorcycle Connect terms of use.
- The Yamaha Motorcycle Connect app may not function on all smartphones or OS (operating system) versions.
- Navigation and other features require GPS access permissions to

# Smartphone Connectivity System

be set as “Always allow” on your smartphone.

- Every smartphone operates differently; refer to your individual device instructions regarding connectivity, Bluetooth discovery, app permissions, and other settings.

5

## Initial setup

EUA4474

### To use smart features:

1. Download/install the Yamaha Motorcycle Connect app on your smartphone via an application store. Complete the installation and pair/connect it to the CCU via Bluetooth.
2. To use the navigation system, download/install the Garmin Motorize app on your smartphone via an application store. Complete the installation and connect it to the CCU via Wi-Fi/USB.
3. To use the audio/phone/navigation systems, pair a Bluetooth headset to the CCU.

## Yamaha Motorcycle Connect pairing

ECAN0150

### **NOTICE**

**The Bluetooth connection may not work in the following situations.**

- **In a location exposed to strong radio waves or other electromagnetic noise.**

- **At facilities nearby that are emitting strong radio waves (TV or radio towers, power plants, broadcasting stations, airports, etc.).**

1. Download and install the Yamaha Motorcycle Connect app on your smartphone.
2. Navigate to: “[App] Applications” → “Settings” → “Connections” → “Bluetooth” in the menu system.
3. Make sure there is a blue checkmark next to “Bluetooth” and select “Make system discoverable”.

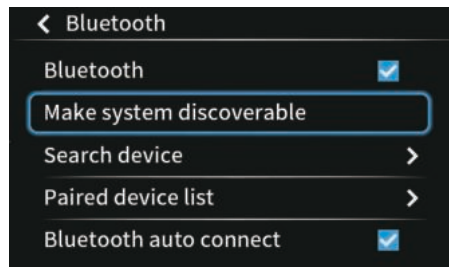

4. Open the Yamaha Motorcycle Connect app and navigate to the pairing display. Follow the instructions on the app to detect the CCU and pair/connect with it.

# Smartphone Connectivity System

**TIP** \_\_\_\_\_  
After making the CCU discoverable, a pairing must be completed within 3 minutes or the process will fail. If a failure occurs, select “Make system discoverable” again to retry.

5. A request for Bluetooth pairing will appear with a passkey matching the one displayed on the smartphone. Operate the joystick to highlight “Pair” and then short press “✓”.



6. Accept the pairing request on your smartphone.

**TIP** \_\_\_\_\_  
● After the passkey appears, the pairing must be confirmed within 30 seconds or it will time out. If a

failure occurs, select “Make system discoverable” again to retry.

- When connected, the Yamaha Motorcycle Connect indicator icon “App” will appear on the top of the main display.

7. If pairing is successful, the vehicle display will transition to the “Paired device list” where your smartphone device name will be listed.

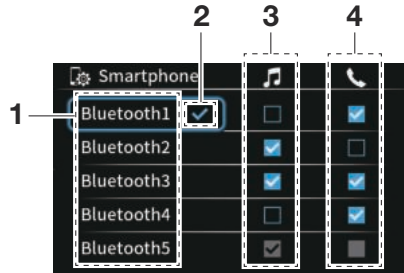

1. Device name
2. Currently connected
3. Connect for audio
4. Connect for telephone

8. The “Audio”, “Telephone”, “Notifications”, and “Weather” functions will become active when the

Bluetooth connection is established.

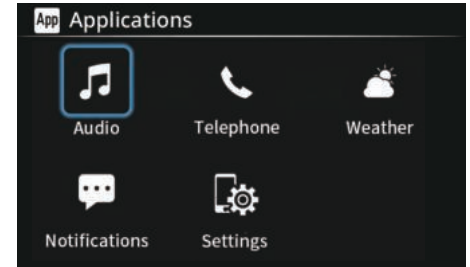

**TIP** \_\_\_\_\_

- A request will appear on your smartphone to share contact information with the vehicle. If you decline to upload the data to the CCU and/or allow access to notifications, you can do so later in your smartphone’s settings.
- If a Bluetooth pairing record is deleted from the smartphone, then the corresponding pairing record must be deleted from the “Paired device list” in order to pair again successfully.
- If a Bluetooth pairing record is deleted from the “Paired device list”, then the corresponding pairing

# Smartphone Connectivity System

5

record must be deleted from the smartphone in order to pair again successfully.

- The first time the vehicle is paired with the Yamaha Motorcycle Connect app, the menu system language will change to match the language selected in the app. When first installed, the app adopts the system language of the smartphone. If the language is not supported by the CCU, then English will be automatically selected.

## Wi-Fi Connection

1. Navigate to: “[App] Applications” → “Settings” → “Connections” → “Wi-Fi hotspot” in the menu system.



2. Open “Wi-Fi hotspot password”. You can use the existing default password or create your own. The password must be at least 8 digits in length. The default password is random.



3. Make sure the blue check appears on the “Wi-Fi hotspot” item, the hotspot name will be displayed in the format “LB# + 10 digit number”.
4. Search for the hotspot via your smartphone’s Wi-Fi settings and connect using the password. The vehicle display will change from “No device connected.” to “Device connected.”.

## TIP

Wi-Fi may not be supported in some countries. If so, use USB connection instead.

## USB connection

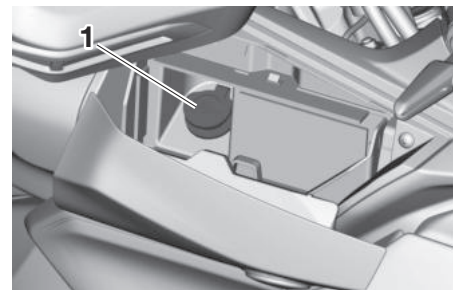

1. USB Type-A jack

Connect a smartphone via the USB jack located in the storage compartment. (See page 6-51.)

ECA27740

## NOTICE

**Take care to avoid damaging the USB jack.**

## Bluetooth Headset Pairing

1. Make your headset discoverable via its Bluetooth settings.
2. Navigate to: “Applications” → “Settings” → “Connections” → “Bluetooth” → “Search device” → “Headset” in the menu system.

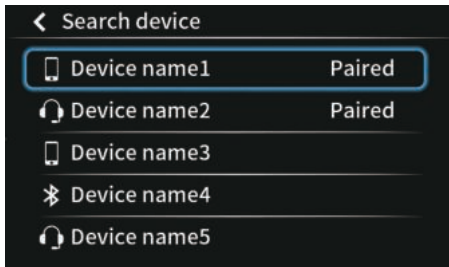

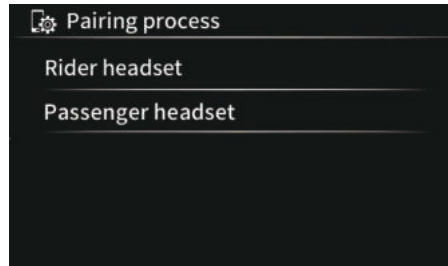

After some time, your headset device name should appear on the list of available devices. Select it from the list.

3. Select to pair as a rider or passenger headset.

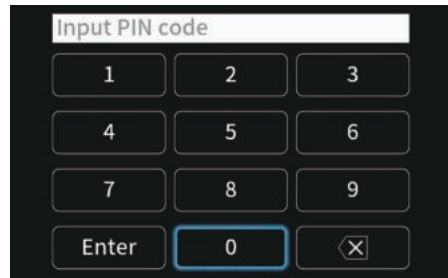

At this point, a PIN code may need to be input for some headset models.



When connected, the display will switch to “Paired device list” and the headset icon “” will appear.

## TIP

Once paired, a headset can be switched between rider-passenger in the “Paired device list”. (See page 6-24.)

# Smartphone Connectivity System

## Navigation system: Garmin Motorize

EUA4900

EWA21401

### **⚠ WARNING**

- Always stop the vehicle before operating the navigation system.
- Always concentrate on riding by keeping your eyes and mind on the road.



This vehicle is equipped with a navigation system which provides visual and audio (Bluetooth headset required) route guidance. To use the navigation system, you must first download the Garmin Motorize app from an application store onto your smartphone.

Navigation also requires the following:

- smartphone connection to the CCU via Wi-Fi or USB
- Yamaha Motorcycle Connect app connection via Bluetooth
- headset connection via Bluetooth (audio route guidance)

### TIP

- Use of the Garmin Motorize app is subject to your agreement to the Garmin Motorize terms of use.
- Yamaha shall not be liable for any damages resulting from the use of the Garmin Motorize app.
- The smartphone must remain unlocked and the Garmin Motorize app must be kept in the foreground in order to ensure the phone does not sleep (lock). If another app's function moves the Garmin Motorize app to the background (phone call, alarm, etc.) the phone may sleep (lock) and the navigation may stop.
- The Garmin Motorize app's GPS access permissions must be set to "Always allow" on your smartphone's settings.

- The Garmin Motorize app may not work on all smartphones or OS (operating system) versions.
- iOS smartphones do not require the Yamaha Motorcycle Connect app for the navigation system when connected via USB.

### How to use the navigation system:

The navigation system is controlled using the joystick/home button:

- Long press the home button "↵" to access the navigation system from the main display.
- Short press "✓" to open the navigation system menu
- Operate the joystick up-down to control the map zoom
- Long press the home button "↵" to exit navigation and return to the main display.

EAU5000



If the navigation system cannot connect to the Garmin Motorize app then this error screen is displayed. Short press “✓” on “OK” to continue.

## Telephone

This vehicle is equipped with a telephone function that utilizes your smartphone and a Bluetooth headset. To use this function, both a smartphone and a Bluetooth headset must be paired and connected to the CCU (see page 5-3). The telephone function is controlled using the joystick/home button (see page 6-3).

### Receiving phone calls:



When a phone call is received to a connected smartphone, the ringtone will play through the connected headset and a telephone function will appear at the bottom of the display. Short press “✓” on the green phone icon to answer the call. The active phone call indicator icon “☎” will appear on the top of the main display for the duration of the call.

## TIP

While an incoming phone call is ringing, the ringtone volume can be adjusted by operating the joystick up-down.

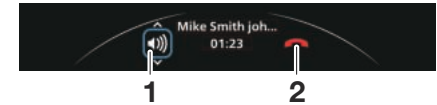

1. Volume
2. End call

Highlight the volume icon and operate the joystick up-down to adjust the call volume. Highlight the end call icon and short press “✓” to hang up the call.

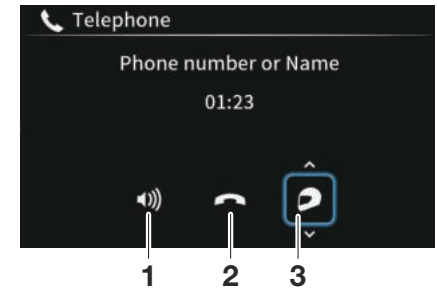

1. Adjust call volume
2. End call

# Smartphone Connectivity System

3. Switch call audio output between Bluetooth headset/smartphone device



Opening the pop-up menu will hide the phone function at the bottom of the display, however, it can be accessed again by navigating to “☎ Telephone” in the menu system. While a call is active, a full-screen active call function can be accessed by navigating to “ Applications” → “Telephone” in the menu system. (see page 6-27)

## TIP

Closing the active call screen using the home button “ ” will not end the call.

Highlight the volume icon and operate the joystick up-down to adjust the call volume level. Highlight the end call icon and short press “ ” to hang up the call.

## Making phone calls:

1. Navigate to: “ Applications” → “Telephone” in the menu system. If a call is not already active, then a recent contact list will appear. Highlight a contact and short press “ ” to start a call, the dis-

play will transition to the active call function.

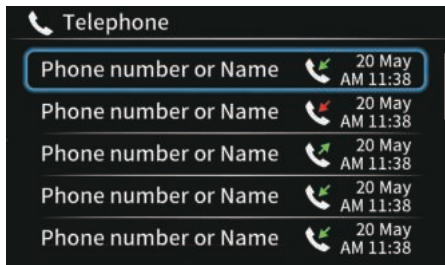

2. You can also make a phone call directly on your smartphone and the telephone function will appear at the bottom of the vehicle display. The call audio will play through the connected Bluetooth headset.

## TIP

If the contact information has not been shared from the smartphone to the CCU, then the recent contact list will only display phone numbers of call events which occur while the smartphone is connected.

EWA21420

## ! WARNING

- Do not use your smartphone while the vehicle is in motion.
- Never take your hands off the handlebars while riding.
- Always concentrate on riding by keeping your eyes and mind on the road.
- Keep volume levels low enough to maintain awareness of your surroundings and ensure safety.

EAUJ4100

## Connection troubleshooting

If a connection error occurs between the smartphone, Yamaha Motorcycle Connect app, Garmin Motorize app and/or CCU, the following screen is displayed.



Select “Details” and check the connection as instructed on the screen.



If the error persists, try the following:

1. Turn OFF the vehicle power. After 30 seconds, turn ON the vehicle power again.
2. Disconnect the USB plug. After 10 seconds, connect the USB plug again.
3. Turn OFF the smartphone's Bluetooth. Then turn it ON again.
4. Delete Bluetooth pairing information from both the smartphone and the CCU to pair them again.
5. Reboot the Yamaha Motorcycle Connect app and the Garmin Motorize app.

# Instrument and control functions

## Handlebar switches

EAU6605B

### Left

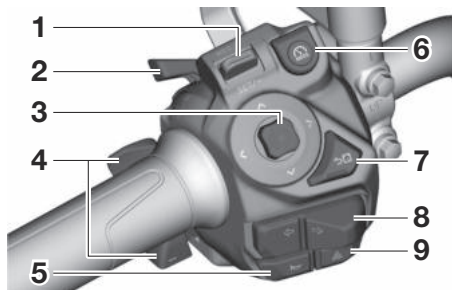

1. ACC/YVSL setting switch “RES/+”/ “SET/-”
2. Headlight switch “/”
3. Joystick “”
4. Shift lever
5. Horn switch “”
6. ACC/YVSL button “”
7. Home button “”
8. Turn signal switch “/”
9. Hazard switch “”

### Right

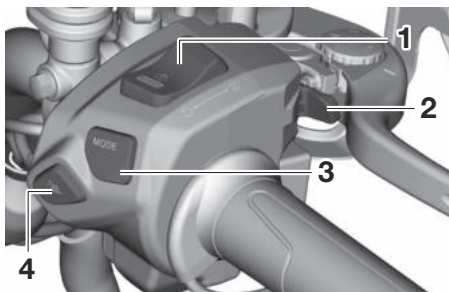

1. Stop/Run/Start switch “/”
2. Y-AMT switch “AT/MT”
3. YRC mode button “MODE”
4. ACC following distance button “”

### Headlight switch “/”

EAU44373

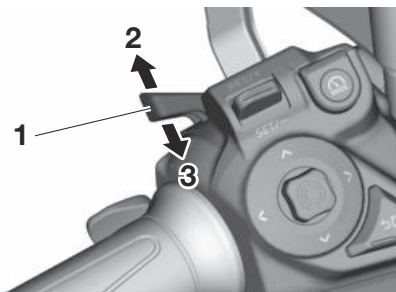

1. Headlight switch “/”

2. Direction A
3. Direction B

Press this switch outward (direction A) to turn on the high beam.

Press and hold the switch outward (direction A) to turn on the adaptive high beam function.

While the headlights are set to high beam/adaptive high beam, press the switch inward (direction B) to return to low beam.

While the headlights are set to low beam, press the switch inwards (direction B) to turn on the high beam until the switch is released.

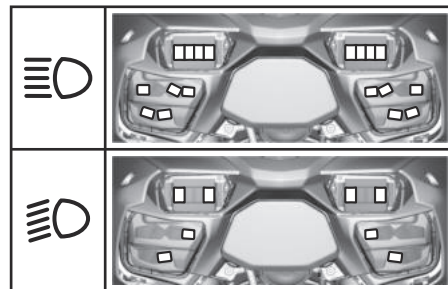

## Turn signal switch “”

EAUJ1741

This switch controls the turn signal lights. This is a 2-stage switch, meaning that pressing it soft or hard has a different effect.

**Soft press:** Lightly press the switch in the direction you wish to signal, until a soft click is felt. The corresponding turn signal light will flash three times and stop.

**Hard press:** Firmly press the switch in the direction you wish to signal, until a stronger click is felt. The corresponding turn signal light will flash continuously until all of the following conditions occur:

- The vehicle travels approx. 150 m (490 ft).
- More than 15 seconds has elapsed.
- The vehicle speed is more than 5 km/h (3 mi/h).

ECA28520

### NOTICE

**Depending on the conditions, the turn signal may not automatically turned off within the specified time or distance travelled.**

To cancel a turn signal manually, press the switch a second time in the same direction.



## Horn switch “”

EAU66030

Press this switch to sound the horn.

## Stop/Run/Start switch “”

EAU94790

To crank the engine with the starter, set this switch to “”, and then push the switch down towards “”. See page 8-2 for starting instructions prior to starting the engine.

Set this switch to “” to stop the engine in case of an emergency, such as when the vehicle overturns.

## Hazard switch “”

EAU95652

With the vehicle power is on, use this switch to turn on the hazard lights (simultaneous flashing of all turn signal lights).

The hazard lights are used in case of an emergency or to warn other drivers when your vehicle is stopped where it might be a traffic hazard. Hazard lights can be turned on/off only when the ve-

hicle power is on. Even after the vehicle power is turned off, they will continue to flash until the vehicle is powered on again and the hazard lights are switched off.

ECA10062

### NOTICE

**Do not use the hazard lights for an extended length of time with the engine not running, otherwise the battery may discharge.**

EAUJ5892

## Adaptive Cruise Control/YVSL switches

ACC/YVSL button “”, ACC/YVSL setting switch “RES/+”/“SET/-” and ACC following distance button “”.

See page 4-12 for an explanation of the adaptive cruise control system.

See page 4-18 for an explanation of the YVSL system.

EAUJ4382

## YRC mode button “MODE”

Short press this button to cycle the YRC mode presets.

# Instrument and control functions

Long press this button to open a YRC mode pop-up at the bottom of the display.  
See page 6-10 and 6-33 for more information.

## Joystick “✓” and home button “↶”

EUAU4390

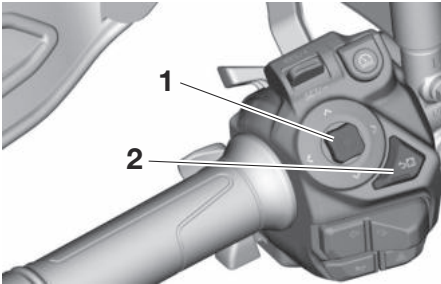

1. Joystick “✓”
2. Home button “↶”

These are used to control the display/menu system.

This manual uses the following terms to describe the usage of the menu controls:

Short press	Briefly press the joystick or button
Long press	Press the joystick or button for 1 second

To open the pop-up menu from the main display:

Short press the home button “↶”

Menu system operation:

- Operate the joystick left-right-up-down to highlight and adjust menu items.
- Short press “✓” to select an item.
- Short press the home button “↶” to cancel/return to previous.
- Long press the home button “↶” to close the menu system.

### TIP

When the navigation system is not connected, the navigation home display cannot be cycled to using the home button “↶”.

See pages 6-9 and 6-20 for more detailed explanations of their function.

## Shift lever

EUAU2720

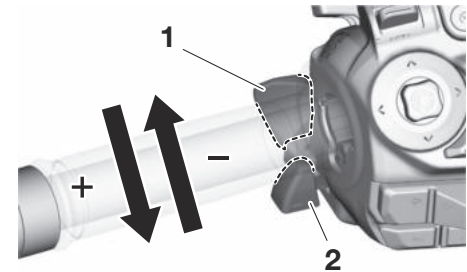

1. Shift lever “+”
2. Shift lever “-”

This lever signals the Y-AMT to shift gears. Press and then release the lever in the “+” direction to upshift. Press and then release the lever in the “-” direction to downshift.

## Y-AMT switch “AT/MT”













EUAU2730

This switch cycles the Y-AMT between automatic mode “AT” and manual mode “MT”.

## Indicator lights and warning lights

EAU5930



1. Tire pressure warning light “”
2. UBS warning light “”
3. Engine trouble warning light “”
4. Neutral indicator light “”
5. High beam indicator light “”
6. Turn signal indicator lights “” and “”
7. Shift indicator light “”
8. ABS warning light “”
9. Stability control indicator light “”
10. Smart key system indicator light “”
11. Y-AMT malfunction indicator light “”

### Turn signal indicator lights “” and “”

EAU88680

Each indicator light will flash when its corresponding turn signal lights are flashing.

### Neutral indicator light “”

EAU91820

This indicator light comes on when the transmission is in the neutral position.

### High beam indicator light “”

EAU88690

This indicator light comes on when the high beam of the headlight is switched on.

### Engine trouble warning light “”

EAU89430

This warning light comes on if a problem is detected in the engine or other vehicle control system. If this occurs, have a Yamaha dealer check the on-board diagnostic system.

### TIP

When the vehicle is turned on, this light should come on for a few seconds and

then go off. Otherwise, have a Yamaha dealer check vehicle.

### Y-AMT malfunction indicator light “”

EAU5940

This light comes on or flashes when there is a problem with the Y-AMT system.

If this light is flashing, the vehicle may be operated but maintenance is needed. Have a Yamaha dealer check the vehicle.

If this light remains on, do not attempt to start the engine or drive the vehicle.

If this light comes on while riding, the Y-AMT system may not work correctly.

If this occurs:

- It may be impossible to shift out of the gear you are in.
- The clutch may stay disengaged, so a shuddering sensation may be felt as you come to a stop.

Stop the vehicle when it is safe to do so, and park it away from traffic. Have a Yamaha dealer check the Y-AMT system.

# Instrument and control functions

## TIP

If shifting is impossible then use the method described on page 9-31 to shift into neutral so that the vehicle may be rolled.

When the vehicle power is turned on, the Y-AMT malfunction indicator light “” should come on for a few seconds and then go off.

If the light does not come on initially when the vehicle power is turned on, or if the light remains on, have a Yamaha dealer check the vehicle.

EAU92700

## ABS warning light “”

In normal operation, the ABS warning light comes on when the vehicle is turned on, and goes off after traveling at a speed of 5 km/h (3 mi/h) or higher.

## TIP

If the warning light does not work as described above, or if the warning light comes on while riding, the ABS may not work correctly. Have a Yamaha dealer check the vehicle as soon as possible.

## WARNING

If the ABS warning light does not turn off after reaching 5 km/h (3 mi/h), or if the warning light comes on while riding:

- Use extra caution to avoid possible wheel lock during emergency braking.
- Have a Yamaha dealer check the vehicle as soon as possible.

EWA21120

## UBS warning light “”

This warning light comes on when the vehicle is turned on and then goes off after traveling at a speed of 5 km/h (3 mi/h) or higher. This warning light also comes on to indicate when brake control (BC) is turned off. If this warning light comes on while already driving, then the UBS and radar-linked UBS may not be working properly.

EAUJA6631

EWA22551

## WARNING

In the following cases, have the vehicle inspected immediately by a Yamaha dealer:

- When the warning light does not come on when the vehicle is turned on.
- When the warning light does not turn off even after driving at a speed of 5 km/h (3 mi/h) or more.
- When the warning light comes on while driving with brake control (BC) on.

EAUJA2750

## Shift indicator light “”

This indicator light comes on when it is time to shift to the next higher gear. The engine speeds at which it comes on or goes off and other settings can be adjusted in the menu system. (See page 6-37.)

## TIP

- The shift indicator light does not operate when the vehicle is in “AT” mode, neutral or 6th gear.
- When the vehicle is turned on, this light should come on for a few seconds and then go off. If the light

does not come on, or if the light remains on, have a Yamaha dealer check the vehicle.

EAU78086

## Smart key system indicator light



This indicator light will flash when communication between the vehicle and smart key takes place and when certain smart key system operations are carried out. The indicator light may also flash when there is an error in the smart key system.

### TIP

When the vehicle is turned on, the light should come on for a few seconds and then go off. If the light does not come on, or if the light remains on, have a Yamaha dealer check the vehicle.

EAU44940

## Stability control indicator light “SC”

When TCS (traction control system) is set to off, this indicator will come on. This indicator light flashes when the TCS (traction control system), SCS (slide control system), LIF (lift control

system), or BSR (back slip regulator) engage while riding.

### TIP

When the vehicle is turned on, this light should come on for a few seconds and then go off. If the light does not come on, or if the light remains on, have a Yamaha dealer check the vehicle.

ECA28471

### NOTICE

**When turning the main switch on, avoid any movement or vibration of the vehicle as it may interfere with the initialization of the IMU. If this occurs, the traction control system will not operate and the stability control indicator light “SC” will come on until the IMU can initialize.**

EAU44161

## Tire pressure warning light “”

This warning light comes on when the air pressure of a tire is low. Stop the vehicle as soon as possible and inspect your tires. **WARNING! Failure to correct low tire pressure can lead to**

## loss of control and serious injury.

[EWA20420]

If a sensor battery is discharged or if a malfunction is detected, this warning light will flash. Have a Yamaha dealer check the vehicle.

### TIP

- When the vehicle is turned on, this light should come on for a few seconds and then go off. Otherwise, have a Yamaha dealer check the vehicle.
- When the TPMS is disabled, the tire pressure warning light will not come on / flash in any case and the tire pressure items on the vehicle information display will not be available.

# Instrument and control functions

EAU1864

## Display

Theme 1

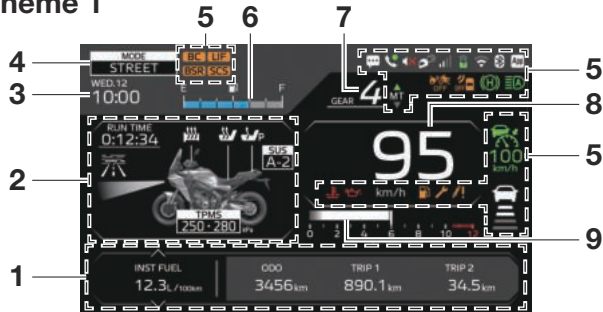

Theme 2



Theme 3

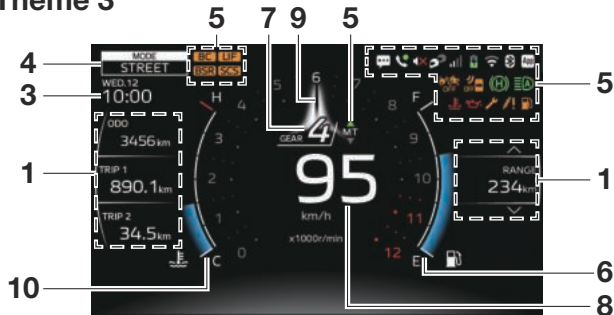

1. Vehicle information display
2. Vehicle status display
3. Clock
4. YRC mode display
5. Indicator icons

6. Fuel meter
7. Transmission gear display
8. Speedometer
9. Tachometer
10. Coolant temperature meter

# Instrument and control functions

## Minimized display view (while menu system/navigation are open)

When the menu system or the navigation function are open, the information on the main display is relocated as shown.



1. Fuel meter
2. Vehicle information display
3. Indicator icons
4. Clock
5. YRC mode display
6. Transmission gear display
7. Speedometer
8. Navigation
9. Menu system

# Instrument and control functions

EAU45658

## TIP

- The brightness level of the display screen can be adjusted in the menu system. (See page 6-31.)
- If the display becomes too hot, the display screen brightness levels will automatically reduce to avoid damage.
- This model uses a thin-film-transistor liquid-crystal display (TFT LCD) for good contrast and readability in various lighting conditions. However, due to the nature of this technology, it is normal for a small number of pixels to be inactive.
- The display measurement units can be changed by going to “Settings” → “Unit” in the menu system. (See page 6-31.)

## Display system controls

The display user interface is controlled with the joystick / “✓” and the home button “↵”. (See page 6-3.) Each control has various functions for different

situations, see the following list for details.

### Operate the joystick left-right-up-down:

Main display active: Up-down cycles the visible items in the vehicle information display. Left-right opens the menu system.

Navigation active: up-down zoom the map view in-out.

YRC mode pop-up active: highlights and adjust different YRC items.

Menu system active: highlight and adjusts various menu items.

### Short press “✓”:

Main display active: open the menu system.

Navigation active: open the navigation system menu.

Menu system active: select highlighted menu items.

### Long press “✓”:

Main display active: Mute audio.

### Short press the home button “↵”:

Main display/navigation active: open the menu system.

Menu system active: cancel/return to previous.

### Long press the home button “↵”:

Main display active: switch to navigation display.

Navigation active: switch to main display.

Menu system active: exit to the previously open main display/navigation display.

## Clock

The clock uses a 12-hour time system. The clock is updated automatically from connected smartphones or can also be manually by going to “Settings” → “Clock” in the menu system. (See page 6-32.)

## Speedometer

The speedometer shows the vehicle’s traveling speed.

## Tachometer

The tachometer shows the engine speed, as measured by the rotational velocity of the crankshaft, in revolutions per minute (r/min).

ECA10032

### NOTICE

**Do not operate the engine in the tachometer red zone.**

**Red zone: 10500 r/min and above**

## Transmission gear display

This display shows which gear the transmission is in. This vehicle has 6 gears and a neutral position. The neutral position is indicated by the neutral indicator light “N” and by the transmission gear display showing: “N”.

## Fuel Meter

The fuel meter indicates the amount of fuel in the fuel tank. The display segments of the fuel meter disappear from “F” (full) towards “E” (empty) as the fuel level decreases. When the last segment starts flashing, refuel as soon as possible.

ECAE0121

### NOTICE

**Do not let the vehicle run completely out of fuel. This may cause damage to the catalytic converter.**

## Coolant temperature meter (Theme 3)

The coolant temperature varies with changes in the weather and engine load. If the coolant temperature exceeds the limit, the coolant meter will start flashing. If this occurs, stop the vehicle and let the engine cool. (See page 9-34.)

## YRC mode display

This display indicates which YRC mode is currently selected: “SPORT”, “STREET”, “RAIN”, “CUSTOM 1”, “CUSTOM 2”, “D+” or “D”.

Cycle through the YRC modes by using the YRC mode button “MODE” and also view/customize them in the menu system. (See page 6-33.)

### TIP

- The available YRC modes differ depending on the current Y-AMT mode (“AT”/“MT”).
- The names of “CUSTOM 1”, “CUSTOM 2”, “D+”, and “D” can also be customized via the Yamaha Motorcycle Connect app.

## YRC Mode pop-up



Long press the YRC mode button “MODE” to open/close an expanded YRC mode pop-up at the bottom of the screen. While the pop-up is open, short press the YRC mode button “MODE” to cycle through the presets and use the joystick to adjust individual items.

### TIP

If the selected YRC mode is customizable, “PWR”, “TCS”, “SCS”, “LIF”, “EBM” and “SUS” can be highlighted and adjusted using the joystick.

# Instrument and control functions

For more information on YRC modes see page 4-23.

## Vehicle information display

The vehicle information display contain can be set to display the following:

- Odometer “ODO”
- Tripmeter “TRIP 1”
- Tripmeter “TRIP 2”
- Average fuel consumption “AVG FUEL”
- Instantaneous fuel consumption “INST FUEL”
- Fuel consumed “FUEL CONS”
- Estimated fuel range “RANGE”
- Fuel reserve tripmeter “TRIP F”
- Air temperature “AIR”
- Coolant temperature “COOLANT”
- Average speed “AVG SPEED”
- Trip timer “TRIP TIME”
- Running time “RUN TIME”
- Front tire pressure “TIRE FRONT”
- Rear tire pressure “TIRE REAR”

Operate the joystick up-down to cycle the visible items.

There are three favorite items which are displayed separately and can be customized by navigating to “Settings”

→ “Vehicle Info” in the menu system. (See page 6-38.)

The three favorited items are also displayed, one at a time, at the top of the navigation screen and other menu screens (minimized display view).

While on the navigation screen, highlight “Vehicle Info” in the pop-up menu and operate the joystick up/down to cycle which information display favorite is shown at the top of the display.

### TIP

If Garmin Motorize is not connected, the vehicle information favorites cannot be cycled on the minimized display view but can be changed by navigating to “Settings” → “Vehicle Info” in the menu system.

To reset information display items:



Select “Vehicle Info” in the menu system. (See page 6-21.) A blue highlight will appear around a information display item. Use the joystick to change the highlighted item. If an item is flashing, long press “✓” to reset it.

### Odometer “ODO”

The odometer shows the total distance traveled by the vehicle.

### TIP

The odometer will lock at 999999 and cannot be reset.

### Tripmeters “TRIP 1” / “TRIP 2”

“TRIP 1” and “TRIP 2” show the distance traveled since they were last set to zero.

“TRIP 1” and “TRIP 2” will reset to 0 and begin counting again after 9999.9 has been reached.

### Average fuel consumption “AVG FUEL”

When using kilometers, the average fuel consumption display can be set to “km/L” or “L/100km”. (See page 6-31.)

# Instrument and control functions

When using miles, the average fuel consumption is displayed in “MPG”.

## Instantaneous fuel consumption “INST FUEL”

When using kilometers, the instantaneous fuel consumption display can be set to “km/L” or “L/100km”. (See page 6-31.)

When using miles, the instantaneous fuel consumption is displayed in “MPG”.

## Fuel consumed “FUEL CONS”

Displays how much fuel has been consumed since the trip meter was last reset.

## TIP

The current fuel consumption function should be used for general reference only. Do not use this figure to estimate the distance that can be traveled on the current tank of fuel.

## Estimated fuel range “RANGE”

The estimated distance that can be traveled under the current riding conditions with the remaining fuel.

## TIP

This item is replaced by “TRIP F” when it is active.

## Fuel reserve tripmeter “TRIP F”

When the fuel tank reserve level has been reached, “TRIP F” activates and begins recording distance traveled from that point. After refueling and traveling some distance, “TRIP F” will automatically deactivate and reset.

## TIP

When “TRIP F” is inactive it is replaced by “RANGE”.

## Air temperature “AIR”

The air temperature is displayed from  $-9\text{ }^{\circ}\text{C}$  ( $15\text{ }^{\circ}\text{F}$ ) to  $50\text{ }^{\circ}\text{C}$  ( $122\text{ }^{\circ}\text{F}$ ) in  $1\text{ }^{\circ}\text{C}$  ( $1\text{ }^{\circ}\text{F}$ ) increments. The displayed temperature may differ from the actual ambient temperature due to the vehicle temperature and other factors.

## TIP

- “---” will be displayed if the detected temperature is lower than  $-9\text{ }^{\circ}\text{C}$  ( $15\text{ }^{\circ}\text{F}$ ).

- “---” will be displayed if the detected temperature is higher than  $50\text{ }^{\circ}\text{C}$  ( $122\text{ }^{\circ}\text{F}$ ).

## Coolant temperature “COOLANT”

The coolant temperature is displayed from  $-30\text{ }^{\circ}\text{C}$  ( $-22\text{ }^{\circ}\text{F}$ ) to  $130\text{ }^{\circ}\text{C}$  ( $266\text{ }^{\circ}\text{F}$ ) in  $1\text{ }^{\circ}\text{C}$  ( $1\text{ }^{\circ}\text{F}$ ) increments.

## TIP

- When using Celsius, the coolant temperature display will read “-30” when the vehicle coolant temperature is below  $-30\text{ }^{\circ}\text{C}$ .
- When using Fahrenheit, the coolant temperature display will read “-22” when the vehicle coolant temperature is below  $-22\text{ }^{\circ}\text{F}$ .
- If the vehicle coolant temperature is too high the coolant temperature display will read “Hi”.

## Average speed “AVG SPEED”

Displays the average traveling speed since last reset.

# Instrument and control functions

## Trip timer “TRIP TIME”

Displays the engine running time since the item was last reset.

## Running time “RUN TIME”

Displays the engine running time since last engine start.

## Front tire pressure “TIRE FRONT” /

## Rear tire pressure “TIRE REAR”

The tire pressures as measured by the TPMS are displayed.

### TIP

- If the TPMS is turned off, “---” is displayed.
- Tire pressure is displayed in increments of 5.

## Vehicle status display (Theme 1)

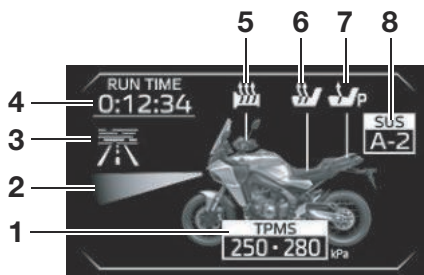

1. Front/rear tire pressure display “TPMS”
2. Headlight beam status indicator
3. Matrix LED headlight detection status indicator
4. Running time “RUN TIME”
5. Grip warmer indicator “Grip”
6. Seat heater indicator “SUS” (if equipped)
7. Passenger seat heater indicator “SUS P” (if equipped)
8. Electronic suspension mode indicator “SUS”

Theme 1 has a vehicle status display which is a visual representation of the vehicle containing the following items:

- Running time “RUN TIME”
- Grip warmer indicator “Grip”
- Seat heater indicator “SUS” (if equipped)

- Passenger seat heater indicator “SUS P” (if equipped)
- Electronic suspension mode indicator “SUS”
- Front/rear tire pressure display “TPMS”
- Headlight beam status indicator
- Matrix LED headlight detection status indicator

## Running time “RUN TIME”

Displays the engine running time since last engine start.

## Grip warmer indicator “Grip”

The grip warmers can be used when the engine is running. There are 3 customizable temperature presets that can be customized between 10 different temperature levels. (See page 6-29.)

The icon displays the current temperature setting:

☐: Grip warmer off

☐: Low preset

☐: Medium preset

☐: High preset

ECA17932





## NOTICE

- Be sure to wear gloves when using the grip warmers.
- Do not use the grip warmers in warm weather.
- If the handlebar grip or throttle grip becomes worn or damaged, stop using the grip warmers and replace the grips.

### Seat heater indicator “” (if equipped)

The seat heater can be used when the engine is running. There are 3 customizable temperature presets that can be customized between 10 different temperature levels. (See page 6-29.)

The icon displays the current temperature setting:

- : Seat heater off.
- : Low preset
- : Medium preset
- : High preset

ECA23980

## NOTICE

- Be sure to wear protective clothing that covers your hip





and legs when using the seat heater.

- If the ambient temperature is 20 °C (68 °F) or higher, do not set the seat heater to the high setting.
- If the seat becomes worn or damaged, stop using the seat heater and replace the seat.

### Passenger seat heater indicator “” (if equipped)

The seat heater can be used when the engine is running. There are 3 customizable temperature presets that can be customized between 10 different temperature levels. (See page 6-29.)

The icon displays the current temperature setting:

- : Seat heater off.
- : Low preset
- : Medium preset
- : High preset

ECA23980

## NOTICE

- Be sure to wear protective clothing that covers your hip

and legs when using the seat heater.

- If the ambient temperature is 20 °C (68 °F) or higher, do not set the seat heater to the high setting.
- If the seat becomes worn or damaged, stop using the seat heater and replace the seat.

### Electronic suspension mode indicator “SUS”

This indicator displays the currently selected YRC mode “SUS” level. (See page 6-35.)

### Front/rear tire pressure display “TPMS”

The tire pressures as measured by the TPMS are displayed. The left side figure indicates the front tire pressure, the right side figure indicates the rear tire pressure.

## TIP

- If the TPMS is turned off, “---” is displayed.

# Instrument and control functions

- Tire pressure is displayed in increments of 5.

## Headlight beam status indicator



1. Low beam
2. High beam

This indicates the current high beam/low beam status of the headlight. It also indicates the high/low status of the adaptive high beam function.

## Matrix LED headlight detection status indicator

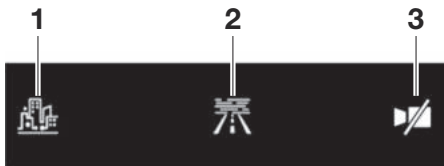

1. Urban
2. Fog
3. Camera detection malfunction

This indicates the currently detected conditions which are causing the adaptive high beam function to switch the matrix LED headlights to low beam.

## ACC/YVSL display



1. ACC/YVSL display

Theme 3: While the ACC or YVSL is active or on standby, the ACC/YVSL display replaces the right-side vehicle information display.



1. ACC/YVSL display

## TIP



For more information about the ACC and YVSL system, see pages 4-12 and 4-18.

ACC indicator “”/“”/“”





This icon comes on if the adaptive cruise control system is on standby, turns green when the system is active (cruising), or amber if there is an error.

# Instrument and control functions

**TIP**  
If this icon comes on in amber, have a Yamaha dealer inspect the vehicle.





YVSL indicator “”/“”/“”  
This icon comes on if the YVSL system is on standby, turns green when the system is active, or amber if there is an error.

**TIP**  
If this icon comes on in amber, have a Yamaha dealer inspect the vehicle.

Set speed indicator “”/“”  
This displays the set speed of the ACC system or YVSL system.  
: speed set, system on standby.  
: speed set, system is active.  
---: speed not set.

Vehicle detection indicator icon “”  
This icon comes on when the ACC system detects a vehicle ahead.

Following distance indicator icon “”  
This displays the current ACC set following distance from the vehicle ahead.

- : shortest distance.
- : short distance.
- : long distance.
- : longest distance.

## Indicator icons

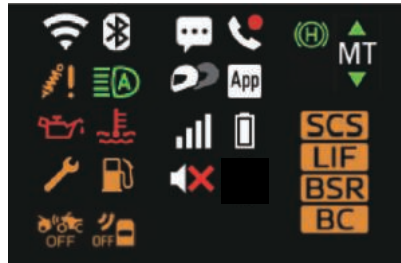

Low fuel indicator icon “”  
This icon comes on when approximately 3.7 L (0.98 US gal, 0.81 Imp.gal) of fuel remains in the tank.

Coolant temperature warning icon “”  
This icon appears when the coolant temperature is high. Stop the vehicle

and turn off the engine. Allow the engine to cool.

ECA10022

## NOTICE

**Do not continue to operate the engine if it is overheating.**

Oil pressure warning icon “”

This icon appears when the engine oil pressure is low. When the vehicle is first turned on, engine oil pressure has yet to build, so this icon will come on and stay on until the engine has been started.

**TIP**  
If a malfunction is detected, the oil pressure warning icon will flash repeatedly.

ECA26410

## NOTICE

**Do not continue to operate the engine if the oil pressure is low.**

Auxiliary system warning icon “”

This icon appears if a problem is detected in a non-engine-related system.

# Instrument and control functions

---

## Y-AMT indicator “AT”/“MT”

This icon and accompanying arrow icons indicate the status of the Y-AMT.

AT: automatic shift mode

MT: manual shift mode

▲: cannot currently upshift.

▼: cannot currently downshift.

▲: upshift available.

▼: downshift available.

### TIP

---

For more information on the Y-AMT see page 4-27.

## FCW OFF indicator “ ”

This icon comes on when the FCW has been turned OFF via the menu system. (See page 6-39.)

### TIP

---

- If this icon also come on if TCS is OFF.
- If this icon remains on even when FCW is ON, have a Yamaha dealer inspect the vehicle.

## BSD OFF indicator “ ”

This icon comes on when the BSD has been turned OFF via the menu system. (See page 6-39.)

### TIP

---

- If this icon also come on if TCS is OFF.
- If this icon remains on even when BSD is ON, have a Yamaha dealer inspect the vehicle.

## VHC indicator “ ” and VHC OFF indicator “ ”

The VHC indicator “ ” will come on in green when the VHC is actively using the brakes to hold the vehicle.

The VHC OFF indicator “ ” comes on when VHC has been turned OFF via the menu system. (See page 6-40.)

### TIP

---

If the VHC OFF indicator “ ” stays on even if the setting is not turned OFF in the menu system, have a Yamaha dealer inspect the vehicle.

## SCU malfunction warning icon “ ”

This icon appears if a problem is detected with the electronic suspension.

## Network connectivity indicator icon “ ”

This icon indicates the connected smartphone’s network connection status.

Icon off: No smartphone connected.

: A smartphone is connected but has no network connectivity.

: A smartphone is connected and has network connectivity. The icon’s segments indicate the signal strength.

## Smartphone battery level indicator icon “ ”

This icon indicates the connected smartphone’s battery level.

Icon off: No smartphone connected.

: The center bar moves up and down to indicate the battery level.

: Smartphone connected via USB.

## Wi-Fi connectivity indicator icon “ ”

This icon indicates Wi-Fi connection status.

Icon off: The vehicle's Wi-Fi function is deactivated.

: The Wi-Fi function is active but is not connected to a smartphone.

: A smartphone is connected via Wi-Fi.

## Bluetooth connectivity indicator icon “”

This icon indicates Bluetooth connection status.

Icon off: The vehicle's Bluetooth function is deactivated.

: The vehicle Bluetooth is active but not connected to a smartphone.

: A smartphone is connected.

## Headset indicator icon “”

This icon comes on if a Bluetooth headset is connected to the vehicle. The icon changes if the headset is changed between rider/passenger connection and if there are two headsets connected at once.

## Yamaha Motorcycle Connect indicator icon “”

This icon comes on when the Yamaha Motorcycle Connect app is successfully connected to the vehicle.

: The icon turns yellow when the connected smartphone becomes overheated.

## TIP

If there is a communication error between the multi-function meter and the CCU, this icon will flash.

## Audio mute indicator icon “”

This icon indicates if audio is muted.

## Telephone indicator icon “”/“”

This icon comes on green when there is an active call and red when there is a recent missed call. The missed call icon will disappear when the recent contact list is opened at “ Applications” → “Telephone” in the menu system.

## Notification indicator icon “”

This icon comes on when the connected smartphone receives an SNS, E-mail or other notification. After that, the

icon stays on until you turn the vehicle off or check the notifications by navigating to “ Applications” → “Notifications” in the menu system.

## TIP

- This function works only when the smartphone is connected to the CCU via the Yamaha Motorcycle Connect.
- Permission to access notifications must be granted to the Yamaha Motorcycle Connect app on the smartphone.

## BC indicator icon “”

This icon comes on if “BC” (brake control system) is deactivated.

ECA28551

## NOTICE

**When turning the main switch on, avoid any movement or vibration of the vehicle as it may interfere with the initialization of the IMU. If this occurs, the brake control system will not operate and the BC indicator “” will come on until the IMU can initialize.**

# Instrument and control functions

## SCS indicator icon “SCS”

This icon comes on if “SCS” (slide control system) is deactivated.



## LIF indicator icon “LIF”

This icon comes on if the “LIF” (lift control system) is deactivated.

## BSR indicator icon “BSR”

This icon comes on if the “BSR” (back slip regulator) is deactivated.

## Adaptive high beam indicator icon

“A” / “A”

This icon comes on in green when the adaptive high beam function is active. It comes on in amber if there is a malfunction with the system.



## Message pop-ups



1

1. Message pop-ups

There are various messages that can pop up at the bottom of the display.

They will disappear after 10 seconds or short press “” or the home button “” to remove the message manually.

## TIP

The default language of the messages is English, however the message language changes according to the language setting of the Yamaha Motorcycle Connect app.

## “Rear brake temperature high”

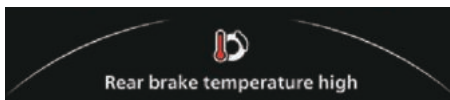

This message will appear if the ACC system causes the rear wheel brake to overheat due to continuous operation.

## “Fuel tank cap open”



This message will appear if the vehicle power is turned on with the fuel tank cap open.

## “Speed too high/low”

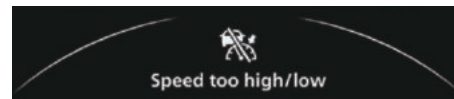

This message will appear if the vehicle speed is too slow/fast for the ACC to activate.

## “ACC deactivated (high/low speed)”

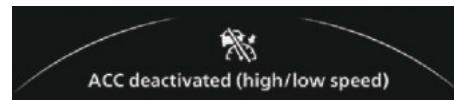

This message will appear if the vehicle cruising speed becomes too slow/fast for the current gear, causing the ACC to deactivate to standby.

## “ACC deactivated (low speed upshift)”



This message will appear if the vehicle upshifts but the cruising speed is too slow for the new gear, causing the ACC to deactivate to standby.

## “Smart key battery low”



This message will appear if the smart key battery becomes low.

## Pop-up menu system

EAU5677



### 1. Pop-up menu

The menu system for this vehicle is controlled with the joystick/home button on the left handlebar. (See page 6-3.)

To open the pop-up menu from the main display:

- Short press the home button “↵”.
- Operate the joystick left-right.
- Short press “✓”.

Menu system operation:





- Operate the joystick left-right-up-down to select and adjust menu items.
- Short press “✓” to execute a selection.
- Short press the home button “↵” to return to the previous screen.

- Long press the home button “↵” to close the menu system.







## TIP

- When arrows appear “↕” surrounding a menu icon, operating the joystick in the direction of the arrows will adjust the selected function.
- Some menu pages and items have a “<” / “>”. If so, operate the joystick in the indicated direction to go forward/back in the menu.
- If the vehicle is in motion “⚙ Settings” will be grayed out in the pop-up menu.

The pop-up menu is divided into the following main functions:

 “Theme”	Select the visual theme of the display. (See page 6-21.)
 “Vehicle Info”	Reset/cycle the vehicle information display items. (See page 6-21.)
 “Music”	Access simple pop-up audio player. (See page 6-21.)
 “Applications”	Access the smartphone application menu. (See page 6-21.)

# Instrument and control functions

 "Phone" (if call active)	Open the telephone function for an active call. (See page 6-28.)
 "Windscreens"	Adjust the windscreen up and down. (See page 6-28.)
 "Grip Warmer"	Control the grip warmers. (See page 6-29.)
 "Seat Heater" (if equipped)	Control the seat heater. (See page 6-29.)
 "P Seat Heater" (if equipped)	Control the passenger seat heater. (See page 6-29.)
 "Settings"	Adjust settings related to the vehicle's operation. (See page 6-29.)

## Theme



The visual theme of the main display can be changed by operating the joystick up-down.

## Vehicle Info



This function is used to reset/cycle individual vehicle information display items. (See page 6-11.)

## Music

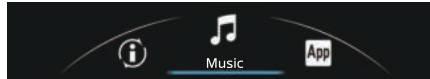

While this menu item is highlighted by arrows as shown, operating the joystick up-down will adjust audio volume accordingly.



Short press "✓" to open a simplified version of the audio player. A full audio player is available by navigating to "App

Applications" → "Audio". (See page 6-22.)

Operate the joystick up-down to adjust the volume. Operate the joystick left-right to skip to previous/next track. Short press "✓" to play/pause.

## Applications



This menu contains smartphone/headset connectivity related functions and settings.

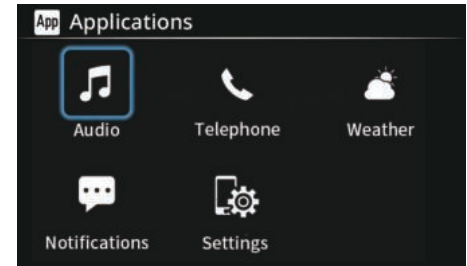

"Settings"	CCU settings (audio / connections / system)
"Audio"	Advanced audio player

# Instrument and control functions

“Telephone”	Telephone function
“Notifications”	Smartphone notification function
“Weather”	Weather information function

## TIP

- The order of the icons can be organized using the Yamaha Motorcycle Connect app.
- Icons for applications that do not have the required CCU connection established will be grayed out.

“ Applications” → “Settings” → “Audio”

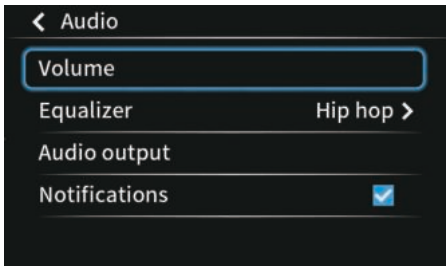

This menu controls volume levels for connected Bluetooth headsets. The “Notifications” option turns audio alerts for notifications on/off.

## TIP

- The volume settings on the connected smartphone are not affected by setting changes in this menu. If the volume is too high or low, try adjusting the volume settings on your smartphone and headset.
- The notification sounds and incoming call ringtones are determined by the smartphone settings.

“ Applications” → “Settings” → “Audio” → “Volume”

EWA21430



**Keep volume levels low enough to maintain awareness of your surroundings and ensure safety.**

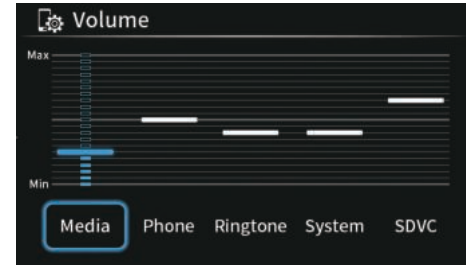

This menu controls volume settings for individual functions:

“Media”: Audio player volume. 20 levels.

“Phone”: Phone call volume. 20 levels.

## TIP

Phone call volume is also adjustable via the pop-up menu telephone function. (See page 6-28.)

“Ringtone”: Incoming call ringtone volume. 10 levels.

“System”: Smartphone system volume. 10 levels.

“SDVC”: Speed dependent volume control (SDVC) is a feature that automatically adjusts the volume based on vehicle speed in order to counteract road noise. Low / Mid / High / OFF.

# Instrument and control functions

“**App** Applications” → “Settings” → “Audio” → “Equalizer”

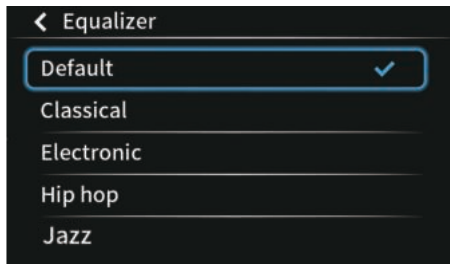

“**App** Applications” → “Settings” → “Audio” → “Audio output”



“**App** Applications” → “Settings” → “Connections”

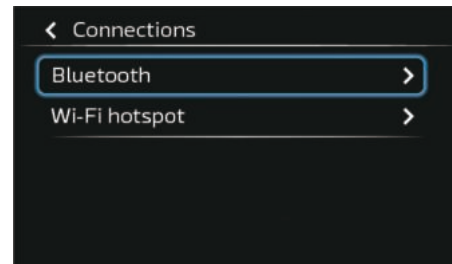

6

Audio output can be adjusted between various equalizer presets. The preset audio levels can be adjusted with the joystick. Short press “✓” to confirm. After modifying an existing preset, it is saved as “Custom”.

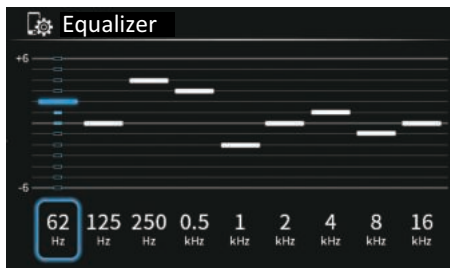

When a Bluetooth headset is connected, the headset icon “” / “” will appear on the top of the display. This setting menu changes the media/navigation and phone call audio between the “Rider headset” “” and “Passenger headset” “”.

## TIP

Only one headset can be selected for phone call audio at a time.

This menu contains the connection settings for Bluetooth and Wi-Fi.

“**App** Applications” → “Settings” → “Connections” → “Bluetooth”

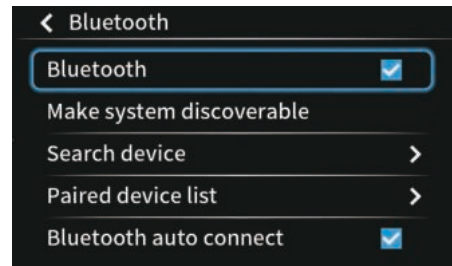

This menu controls Bluetooth connections to smartphones and headsets.

# Instrument and control functions

For instructions on pairing / connecting Bluetooth devices. (See page 5-3, 5-6.)

## TIP

If “Bluetooth auto connect” is enabled, the CCU will automatically connect with any previously paired devices which are available. If “Bluetooth auto connect” is disabled, previously paired devices can be connected manually via the “Paired device list” menu.

“**Applications**” → “**Settings**” → “**Connections**” → “**Bluetooth**” → “**Paired device list**”

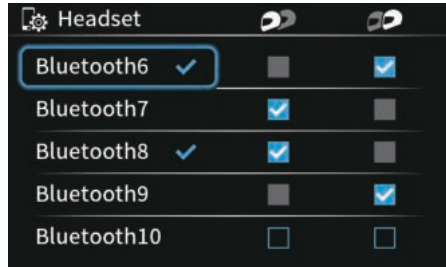
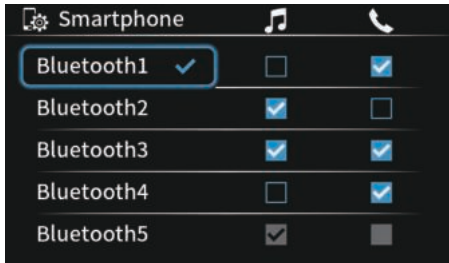

This menu contains lists of previously paired devices. When a device is connected, a blue check will appear next to the device name.

Sound from smartphones can be selected for audio and phone audio.

Bluetooth headsets can be switched between rider and passenger modes.

Selecting a device name will display options for that device.

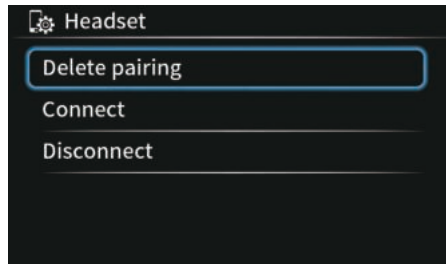

The selected device can be connected (if in range with Bluetooth active), disconnected, and the pairing record can be deleted.

## TIP

- If a Bluetooth pairing record is deleted from the smartphone, then the corresponding pairing record must be deleted from the “Paired device list” in order to pair again. If a Bluetooth pairing record is deleted from the “Paired device list”, then the corresponding pairing record must be deleted from the smartphone in order to pair it again.

“**Applications**” → “**Settings**” → “**Connections**” → “**Wi-Fi hotspot**”

This menu controls Wi-Fi connections to smartphones. (See page 5-7.)

“**Applications**” → “**Settings**” → “**System**” → “**System information**”

This menu displays the current system software version and allows updates via USB storage device.

# Instrument and control functions

Occasional software updates may be released for the CCU. Periodically check Yamaha's homepage for details.

ECA27751

## NOTICE

**Keep the vehicle power on and do not disconnect the USB storage device until data transfer is complete.**

To update system software:

1. Visit the Yamaha homepage and download the latest software update to a USB storage device. Connect it to the USB jack. (See page 6-51.)

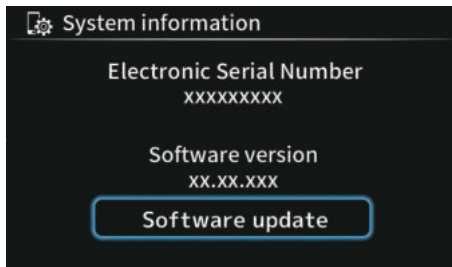

2. Select "Software update".

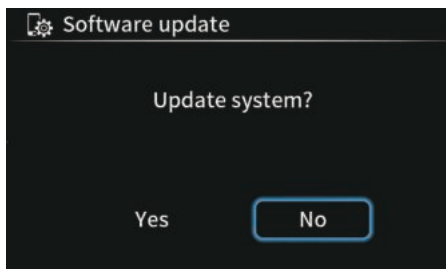

3. Select "Yes" to start the software update. When the update is completed properly, "Completed." is displayed.

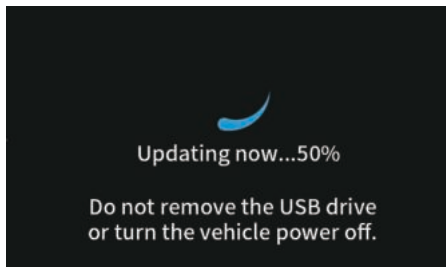

## TIP

Do not turn the vehicle power off, remove the USB drive, or put the vehicle in motion until the update is completed.

ECA27740

## NOTICE

**Take care to avoid damaging the USB jack.**

"App Applications" → "Settings" → "System" → "Inspection mode"

This menu displays the status of CCU connections and the joystick/home button.

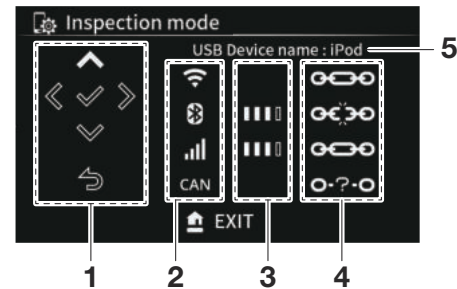

1. Joystick / Home button status
2. Type of connection
3. Signal strength
4. Connection status
5. Connected USB device name

The types of connection are:

- Wi-Fi
- Bluetooth

# Instrument and control functions

: Mobile network

: CAN (controller area network: connection between the CCU and the multi-function meter)

The types of connection status are:

: Connected

: Disconnected

: Connection status unknown

## TIP

This menu cannot be exited by short press of the home button. Long press the home button “” to exit.

“ Applications” → “Settings” → “System” → “Legal”

Third-party license agreements can be viewed here.

“ Applications” → “Settings” → “System” → “All Reset”

Use this menu to reset the CCU and all its related settings, pairings, and stored data.

## TIP

- After a reset, the CCU will several minutes to reboot.

- Before selling or changing ownership of the vehicle, reset the CCU to ensure all personal data from your smartphone (i.e., call history and contact information) is deleted.
- After the CCU is reset, Bluetooth pairing records must be deleted from your smartphone. If this is not completed, the CCU will not be able to pair with the smartphone again.
- The CCU cannot be reset while the vehicle is in motion.

3. Play/Pause
4. Repeat OFF / Repeat all / Repeat one
5. Shuffle
6. Volume level

Operate the joystick up-down to change the volume level. Operate the joystick left-right to select individual functions (Browse, Previous/Next track, Play/Pause, Repeat off/Repeat all/Repeat one) and short press “” to execute the selection.

“ Applications” → “Audio”



1. Browse
2. Previous / Next track

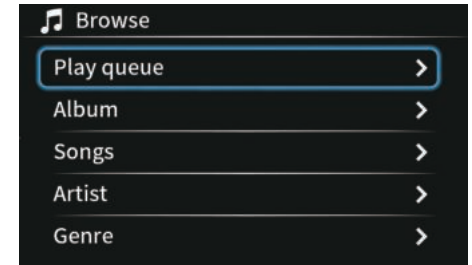

All audio track information is imported from the music player application on your smartphone.

## TIP

- Audio player applications may need to be already open on the connected smartphone.

# Instrument and control functions



- Depending on the smartphone and music player application, the audio player may start playing automatically and the “Audio” screen functions may not work.

## “ Applications” → “Telephone”

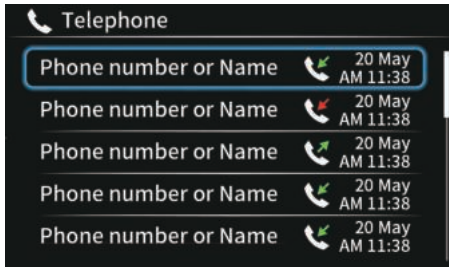
If no call is active then a recent contact list will appear:



Recent call history is displayed. Short press “✓” to start a call with the selected contact.

- : Outbound call (green arrow)
- : Inbound missed call (red arrow)
- : Inbound call (green arrow)

## TIP

- Repeated calls for the same contact are indicated by the number next to the contact in brackets.
- The maximum number of stored items is 30; when the limit is reached, older items will be deleted.

If a call is started by selecting a name/number from the list the following active call screen will appear:

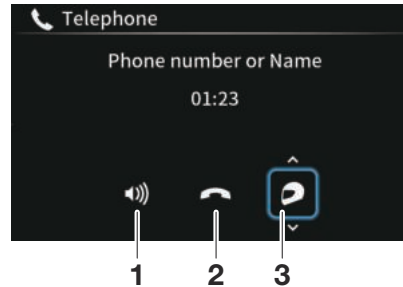

1. Adjust call volume
2. End call
3. Switch call audio output between Bluetooth headset/smartphone device

When the volume icon is highlighted, operate the joystick up-down to adjust the call volume.

Short press “✓” on the phone icon to end the call.

## TIP

- Exiting this menu with the home button “” will not end a call in progress. (See page 6-28.)
- Permission must be granted on the smartphone before contact information can be downloaded to the CCU.
- It takes some time to download contact information. If you receive a call before the download is complete, only the phone number will be displayed.

## “ Applications” → “Notifications”

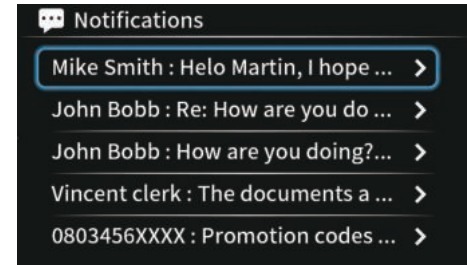

# Instrument and control functions

This is a list of notifications (since connection to vehicle) from the connected smartphone. Select one to read the notification message on the vehicle display. When a notification is received from the connected smartphone, the notification indicator icon “☰” will appear (see page 6-16). Short press “✓” to view a notification.

## TIP

- After all new notifications have been viewed, the notification indicator icon “☰” will disappear.
- The maximum number of stored items is 100; when the limit is reached, older items will be deleted.
- If the message is too long then not all of it will be displayed.
- Messages cannot be opened and read while the vehicle is in motion.

## “App Applications” → “Weather”

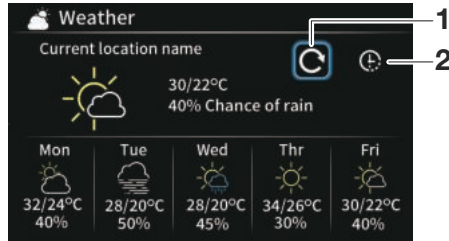

1. Update icon
2. Hourly/Daily interval icon

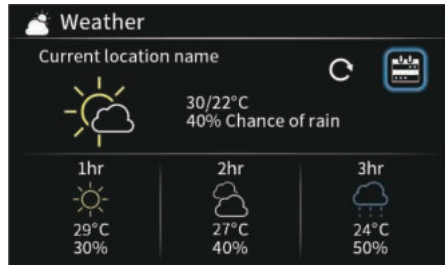

Weather information is shown here. Update the information from your smartphone using the update icon. Change the time interval of the display using the hourly/daily interval icon.

## “Phone”

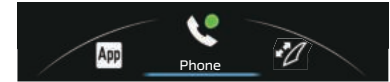

When there is an active call, this item will appear in the pop-up menu. Selecting it will open the telephone function at the bottom of the display. (See page 5-8.)

## “Windscreen”



Operate the joystick up-down to adjust the windscreen height.

## TIP

If the windscreen is adjusted continuously for an extended time, the system will overheat and disable itself until cooled.

# Instrument and control functions

## “Grip Warmer”



With this item highlighted, operate the joystick up-down to cycle between grip warmer OFF and 3 presets which can be customized in “Settings” → “Grip Warmer”. (See page 6-30.)

The grip warmer icon in the pop-up menu shows the currently selected grip warmer preset.

- : Grip warmer off
- : Low preset
- : Medium preset
- : High preset

## “Seat Heater” (if equipped)



With this item highlighted, operate the joystick up-down to cycle between seat heater OFF and 3 presets which

can be customized in “Settings” → “Seat Heater” → “Rider Seat Heater”. (See page 6-30.)

The seat heater icon in the pop-up menu shows the currently selected seat heater preset.

- : Seat heater off.
- : Low preset
- : Medium preset
- : High preset

## “P Seat Heater” (if equipped)



With this item highlighted, operate the joystick up-down to cycle between passenger seat heater OFF and 3 presets which can be customized in “Settings” → “Seat Heater” → “Passenger Seat Heater”. (See page 6-30.)

The passenger seat heater icon in the pop-up menu shows the currently selected seat heater preset.

- : Seat heater off.
- : Low preset

- : Medium preset
- : High preset



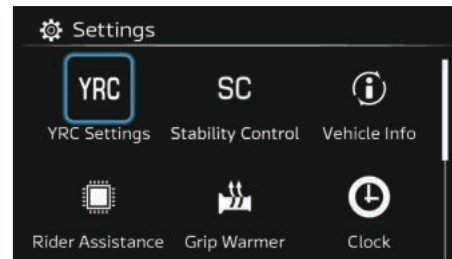



## “Settings”



The “Settings” menu contains the following:

“Grip Warmer”	Customize the grip warmer presets. (See page 6-30.)
“Seat Heater” (if equipped)	Customize the seat heater presets. (See page 6-30.)
“Maintenance”	View/reset maintenance interval tripmeters. (See page 6-31.)
“Unit”	Change the display units. (See page 6-31.)
“Display”	Change display brightness and background settings. (See page 6-31.)

# Instrument and control functions

 "Clock"	Adjust time/set automatic update. (See page 6-32.)
 "All Reset"	Reset to default settings. (See page 6-32.)
<b>YRC</b> "YRC Settings"	Adjust Yamaha Ride Control settings. (See page 6-33.)
 "SUS Calibration"	Calibrate the electronic suspension. (See page 6-36.)
 "Shift Indicator"	Change the shift indicator settings. (See page 6-37.)
 "Vehicle Info"	Customize vehicle information display favorites. (See page 6-38.)
<b>SC</b> "Stability Control"	Turn stability control systems on/off. (See page 6-38.)
 "Rider Assistance"	Settings for rider assistance systems. (See page 6-39.)

 "Settings" →  "Grip Warmer"

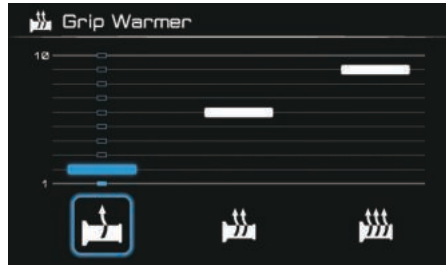

The three grip warmer presets can be customized here. Select a preset by operating the joystick left-right and adjust its heat level from 1-10 by operating the joystick up-down. Short press "✓" to confirm and return to the previous menu.

 "Settings" →  "Seat Heater" (if equipped)

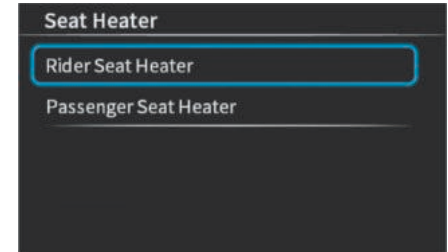

The three seat heater presets for the rider and passenger seats can be customized here. Select a preset by operating the joystick left-right and adjust its heat level from 1-10 by operating the joystick up-down. Short press "✓" to confirm and return to the previous menu.



# Instrument and control functions

“Settings” → “Maintenance”

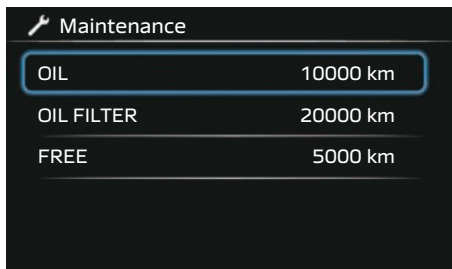

“Settings” → “Unit”

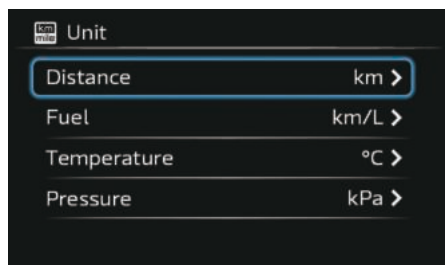

“Settings” → “Display”

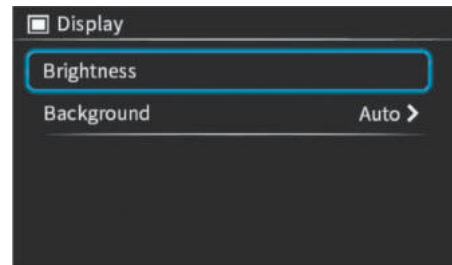

6



This menu allows you to record distance traveled between engine oil changes “OIL” oil filter changes “OIL FILTER” and one other maintenance item of your choice “FREE”.

After maintenance to one of the items has been completed, short press “✓” and confirm to reset the selected item.

The display units can be customized as follows:

- “Distance”: “km” or “mile”
- “Fuel”: “km/L”, “L/100km” or “MPG”
- “Temperature”: “°C” or “°F”
- “Pressure”: “kPa”, “psi”, or “kgf/cm2”

## TIP

When “mile” is selected for the mileage unit, the fuel consumption unit is automatically changed to “MPG”. At this time, “Fuel” is grayed out and cannot be selected.

The multi-function meter is equipped with a sensor to detect ambient lighting conditions and adjust the display brightness between day/night presets automatically or manually.

## “Brightness”

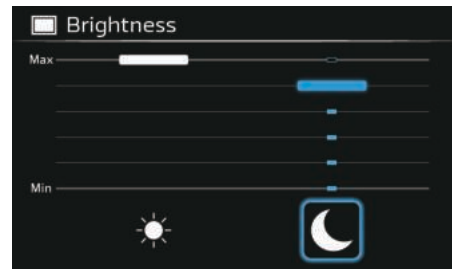

Select a day/night preset by operating the joystick left-right and adjust its

# Instrument and control functions

brightness level from 1-6 by operating the joystick up-down. Short press “✓” to confirm and return to the previous menu.

## “Background”

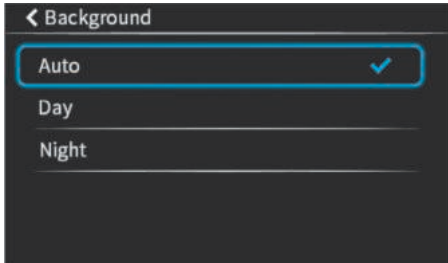

Select “Auto” to enable automatic switching depending on the ambient light levels.

Select “Day” (white) or “Night” (black) to keep the display in that preset.

### TIP

Only “Night” (black) is available for Theme 3.

## “Settings” → “Clock”

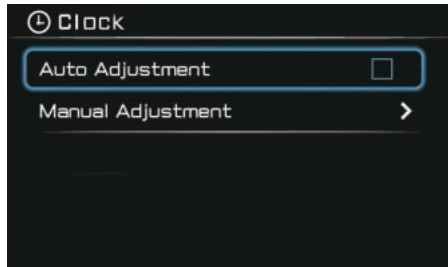

The clock can be set to auto adjust in sync with a smartphone. Auto-adjustment requires a connection between the CCU and the Yamaha Motorcycle Connect app. (See page 5-1.)

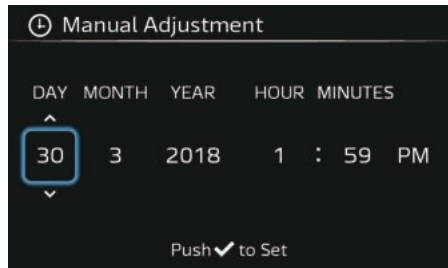

To manually adjust the clock, highlight items by operating the joystick left-right. Operate the joystick up-down to adjust the value of the highlighted item.

Short press “✓” to set the clock and return to the previous menu.

## “Settings” → “All Reset”

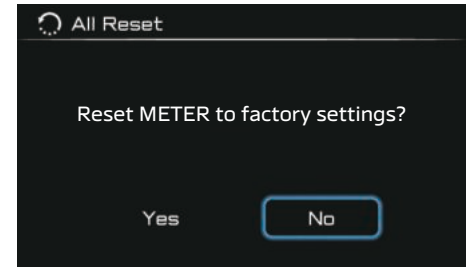

Use this function to reset all machine settings including YRC settings, display brightness, grip warmer presets, seat heater presets, stability control systems, display units, and all resettable vehicle information display items.

### TIP

This reset does not affect the CCU. To reset the CCU see page 6-26.

# Instrument and control functions

“Settings” → “YRC Settings”

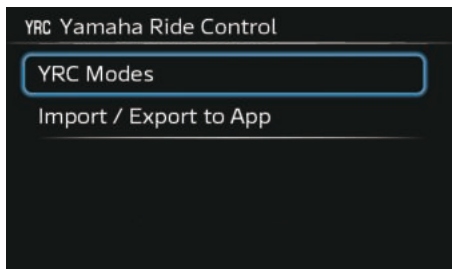

This menu contains various settings and functions for the YRC modes.

“Settings” → “YRC Settings” → “YRC Modes”

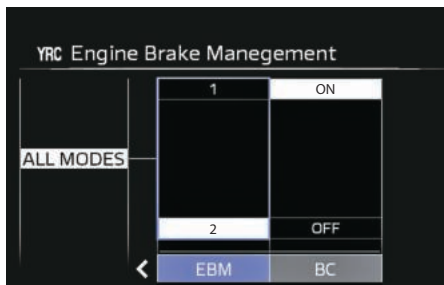
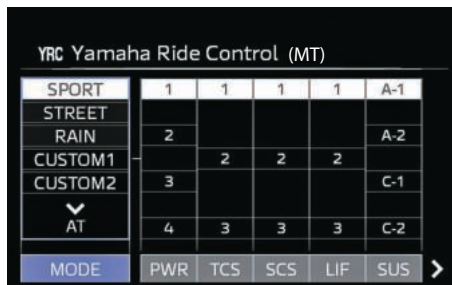

This menu allows you to:

- View the five “MT” YRC mode presets: “SPORT”, “STREET”, “RAIN”, “CUSTOM 1” and “CUSTOM 2”.
- View the two “AT” YRC mode presets: “D+” and “D”.
- Customize the “PWR”, “TCS”, “SCS”, “LIF” and “SUS” setting levels for the “CUSTOM 1”, “CUSTOM 2”, “D+”, and “D” YRC mode presets.
- Customize the “EBM” and “BC” setting levels for all YRC mode presets.

Operate the joystick up-down to select the YRC mode preset that you want to adjust.

Operate the joystick left-right to select the YRC item that you want to adjust. Adjust the selected YRC item by operating the joystick up-down.

Short press “✓” to switch to a visual representation of the highlighted YRC item. Short press the home button “↶” to exit the visual representation.

Short press the home button “↶” to save and go back to the previous menu.

## TIP

- The names and setting levels for “CUSTOM 1”, “CUSTOM 2”, “D+”, and “D” can also be changed via the Yamaha Motorcycle Connect app. (See page 6-36.)
- Adjustments to “EBM” and “BC” settings affect all YRC mode presets.

# Instrument and control functions

## “PWR” (Power delivery mode)

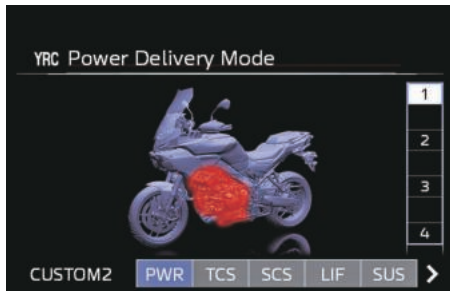

“PWR” can be set to 1, 2, 3 and 4. (See page 4-23.)

Level 1 - Sporty engine response.

Level 2 - Moderate engine response.

Level 3 - Mild engine response.

Level 4 - Rainy days or whenever less engine power is desirable.

### TIP

In the two “AT” YRC mode presets “D+” and “D”, only “PWR” levels 2, 3, and 4 are available.

## “TCS” (Traction control system)

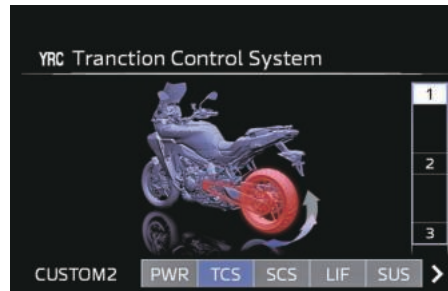

This model uses a variable traction control system. For each setting level, the farther the vehicle is leaned over, the more traction control (system intervention) is applied. There are 3 setting levels available. Level 1 applies the least system intervention, while level 3 applies the most overall traction control to reduce rear wheel slippage. (See page 4-24.)

Level 1 - Suitable for more sporty riding.

Level 2 - Suitable for street riding.

Level 3 - Suitable for riding on wet or slippery surfaces.

### TIP

This system can only be turned off completely via “Settings” → “Stability Control”. (See page 6-38.)

## “SCS” (Slide control system)

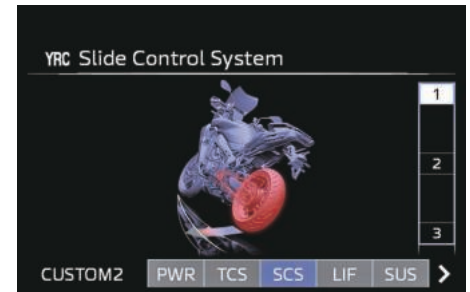

“SCS” can be set to 1, 2, and 3. Setting level 1 provides the least amount of system intervention, and setting level 3 provides the greatest amount of system intervention to reduce lateral wheel slippage. (See page 4-24.)

Level 1 - Suitable for racing more sporty riding.

Level 2 - Suitable for street riding.

Level 3 - Suitable for riding on wet or slippery surfaces.

# Instrument and control functions

## TIP

This system can only be turned off completely via “Settings” → “Stability Control”. (See page 6-38.)

## “LIF” (Lift control system)

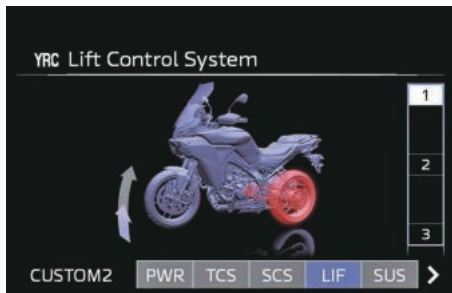

“LIF” can be set to 1, 2, and 3. Setting level 1 provides the least amount of system intervention and setting 3 most strongly reduces the amount of wheel lift. (See page 4-25.)

Level 1 - Least lift control. Suitable for more sporty riding.

Level 2 - More lift control. Suitable for sporty riding.

Level 3 - Most lift control. Suitable for street riding.

## TIP

This system can only be turned off completely via “Settings” → “Stability Control”. (See page 6-38.)

## “SUS” (electronically adjustable suspension)

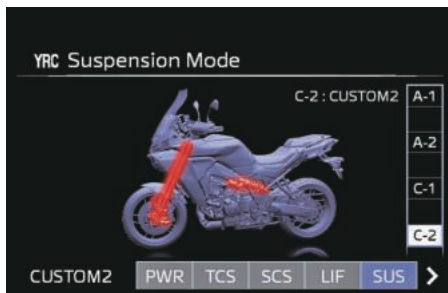

“SUS” can be set to A-1, A-2, C-1, and C-2. A-1 is a sporty setting with increased damping force, suitable for smoother road conditions. A-2 is a comfort setting with softer damping force, suitable for rougher road conditions. C-1 and C-2 are customizable settings via the Yamaha Motorcycle Connect app. (See page 4-25.)

## “EBM” (Engine brake management)



“EBM” can be set to 1 or 2. Setting level 1 provides the least amount of system intervention and setting 2 most strongly reduces engine braking. (See page 4-25.)

Level 1 - The least system intervention and therefore the most engine braking.

Level 2 - The most system intervention and therefore the least engine braking.

# Instrument and control functions

## “BC” (Brake control system)

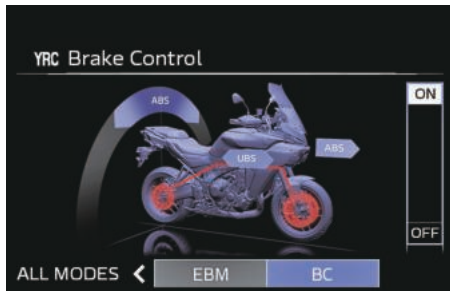

OFF: Only the standard ABS (anti-lock brake system), which adjusts brake pressure based on vehicle speed and wheel speed data. The standard ABS is designed to engage and maximize braking when the vehicle is upright.

ON: ABS (Anti-lock brake system) and cornering assist braking are both active. In addition to the standard ABS, it suppresses the increase in brake pressure when unavoidable abrupt braking occurs during cornering, making the vehicle’s recovery to upright position more gradual.

Also, additional data from the IMU regulates applied brake power depending on lean angle in order to increase the

feeling of stability and to suppress wheel lock.

See page 4-26 for more information on the brake system.

### TIP

- For skilled riders or when track riding, a variety of conditions may cause BC to brake faster than expected for a desired cornering speed or intended cornering line.
- If BC is set to OFF, UBS does not operate.

## “Settings” → “YRC Settings” → “Import / Export to App”

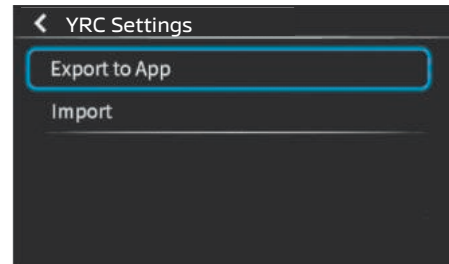

This menu allows you to import/export custom YRC mode settings using the Yamaha Motorcycle Connect app.

## “Settings” → “SUS Calibration”

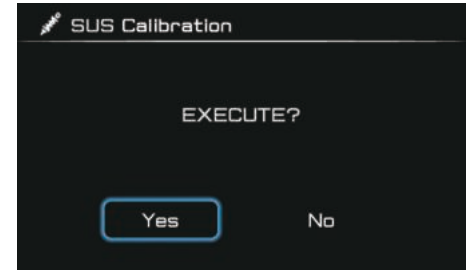

After any service to the rear suspension, a sensor calibration must be performed. Select “Yes” and within approx. 10 seconds the result of the calibration (success/failed) will be displayed.

### TIP

When performing the sensor calibration, place the motorcycle on the centerstand and there should be no weight on the motorcycle.

# Instrument and control functions

“Settings” → “Shift Indicator”

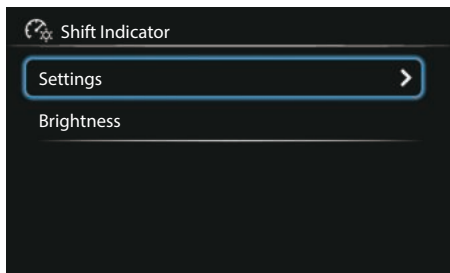

This menu contains settings for the shift indicator light.

“Settings” → “Shift Indicator” → “Settings” → “Indicator Type”

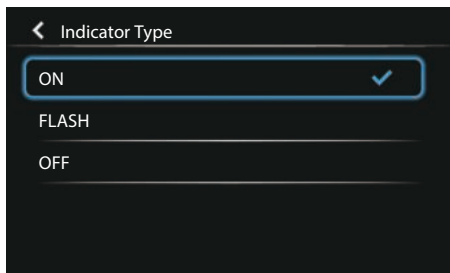

Select “ON” to have the indicator light steadily, “FLASH” to have the shift indicator flash when the indicator start threshold has been reached, or “OFF”

to turn the indicator off. Short press “✓” to confirm and return to the previous menu.

## TIP

The shift indicator light will come on and flash as a demonstration of each setting in this menu as it is selected.

“Settings” → “Shift Indicator” → “Settings” → “Initial”

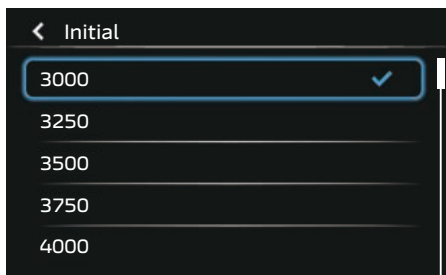

Select the r/min at which the shift indicator light will come on. The operational range is 3000–10250 r/min. It can be adjusted by 250 r/min increments. Short press “✓” to confirm and return to the previous menu.

## TIP

The “Initial” r/min cannot be higher than the “Final” r/min.

“Settings” → “Shift Indicator” → “Settings” → “Final”

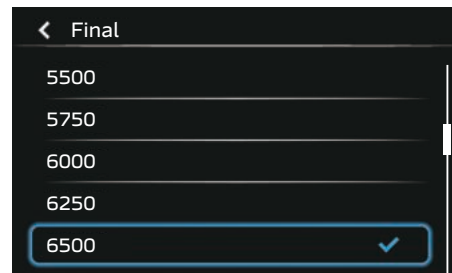

Select the r/min at which the shift indicator light will go off. The operational range is 3250–10500 r/min. It can be adjusted by 250 r/min increments. Short press “✓” to confirm and return to the previous menu.

## TIP

- The “Initial” r/min cannot be higher than the “Final” r/min.

# Instrument and control functions

- The shift indicator light does not come on when in neutral or 6th gear.

“Settings” → “Shift Indicator” → “Brightness”



Select the brightness level of the shift indicator light from 1-6 by operating the joystick up-down. Short press “✓” to confirm and return to the previous menu.

“Settings” → “Vehicle Info”

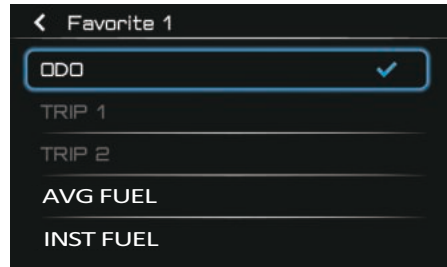
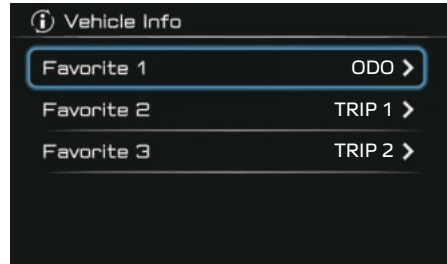

The three vehicle information display favorites can be selected here. (See page 6-11.)

“Settings” → “SC Stability Control”

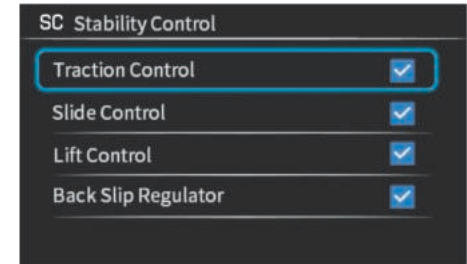

This menu allows you to activate/deactivate the stability control systems: “Traction Control” (TCS), “Slide Control” (SCS), “Lift Control” (LIF), and “Back Slip Regulator” (BSR). (See page 4-23.)

If a system is turned off, the corresponding indicator will come on. (See page 6-16.)

Turning on/off TCS will turn SCS, LIF and BSR on/off together. The stability control system indicator light “SC” will come on to indicate TCS OFF status. (See page 6-6.)

# Instrument and control functions

**TIP**  
TCS turns on automatically when the vehicle power is turned on.

“Settings” → “Rider Assistance”

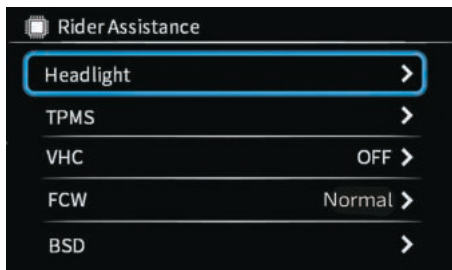

This menu contains various settings for the rider assistance functions.

“Settings” → “Rider Assistance” → “Headlight”



“Response”: The detection response of the matrix LED headlight camera affects how quickly the matrix LED headlight changes pattern when in adaptive mode. It can be adjusted between:

- “Slow”: adjusts smoothly but reacts slower to rapid changes in light.
- “Middle”: A balanced setting between response speed and smoothness.
- “Fast”: adjusts quickly, allowing rapid adaptation to changing light conditions.

“Driving Lane”: the matrix LED headlight camera driving lane setting. Select

“Left” or “Right” match local traffic regulation.

“Settings” → “Rider Assistance” → “TPMS”

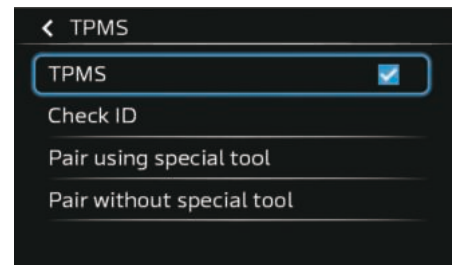

This menu contains various options and settings for the TPMS (Tire Pressure Monitoring System). “TPMS” is used to enable / disable the TPMS. When the TPMS is disabled, the tire pressure warning light will not come on / flash in any case and the tire pressure items on the vehicle information display will not be available. The other items in this menu (“Check ID”, “Pair using special tool”, “Pair without special tool”) are for dealer usage only.

# Instrument and control functions

“Settings” → “Rider Assistance” → “VHC”



This menu contains settings for VHC (Vehicle Hold Control). (See page 4-30.)

- “Standard”: when hard pressure is applied to either the brake lever or brake pedal while the vehicle is stopped, the system keeps the brakes engaged until VHC is deactivated.
- “Advanced”: same as “Standard” mode but additionally when on an incline, the system automatically keeps the brakes engaged after the vehicle is stopped.
- “OFF”: disables the VHC system and the VHC OFF indicator “

“Settings” → “Rider Assistance” → “FCW”

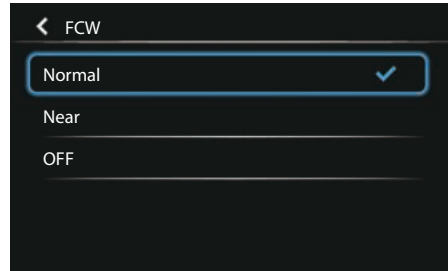

This menu contains settings for FCW (Front Collision Warning). (See page 4-9.)

- “Normal”: FCW is on.
- “Near”: FCW is on with reduced detection range for vehicles ahead.
- “OFF”: disables the FCW system and the FCW OFF indicator “

“Settings” → “Rider Assistance” → “BSD”

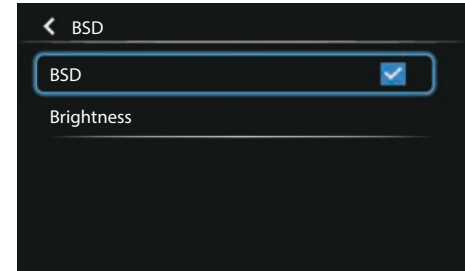

This menu contains settings for BSD (Blind Spot Detection). (See page 4-10.)

“BSD”: disables/enables the BSD system. When disabled, the BSD OFF indicator “

6

# Instrument and control functions

“Settings” → “Rider Assistance”  
→ “BSD” → “Brightness”

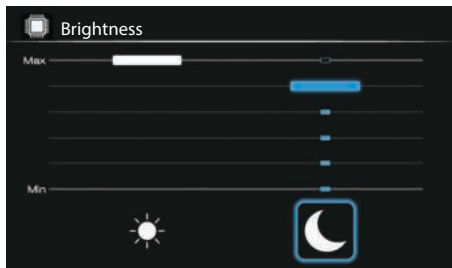

Select the brightness of the BSD indicators on the side mirrors from levels 1-6 and day/night presets. Short press “✓” to confirm and return to the previous menu.

EAU26827

## Brake lever

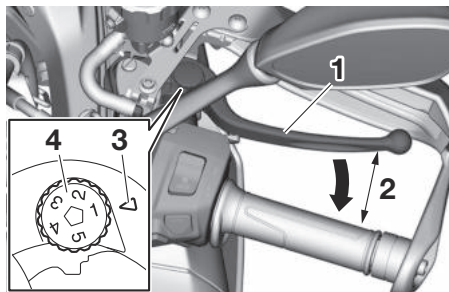

1. Brake lever
2. Distance
3. Match mark
4. Adjusting dial

The brake lever is located on the right side of the handlebar. To apply the front brake, pull the lever toward the throttle grip.

The brake lever is equipped with a brake lever position adjusting dial. To adjust the distance between the brake lever and the throttle grip, push the brake lever away from the throttle grip and rotate the adjusting dial. Make sure the setting number on the adjusting dial aligns with the match mark on the brake lever.

EAU12944

## Brake pedal

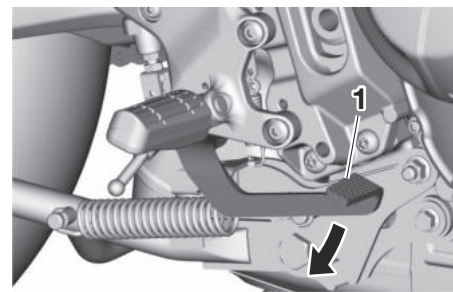

1. Brake pedal

The brake pedal is located on the right side of the motorcycle. To apply the rear brake, press down on the brake pedal.

## Fuel

Make sure there is sufficient gasoline in the tank.

EAU13222

EWA10882



**WARNING**

**Gasoline and gasoline vapors are extremely flammable. To avoid fires and explosions and to reduce the risk of injury when refueling, follow these instructions.**

1. Before refueling, turn off the engine and be sure that no one is sitting on the vehicle. Never refuel while smoking, or while in the vicinity of sparks, open flames, or other sources of ignition such as the pilot lights of water heaters and clothes dryers.
2. Do not overfill the fuel tank. When refueling, be sure to insert the pump nozzle into the fuel tank filler hole. Stop filling when the fuel reaches the bottom of the filler tube. Because fuel expands when it heats up, heat from the engine or the sun can cause fuel to spill out of the fuel tank.

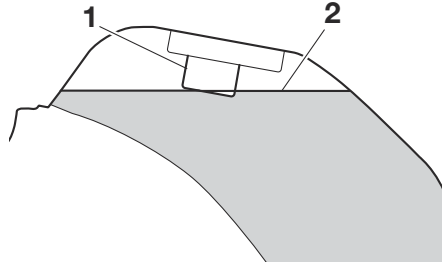

1. Fuel tank filler tube
2. Maximum fuel level
3. Wipe up any spilled fuel immediately. **NOTICE: Immediately wipe off spilled fuel with a clean, dry, soft cloth, since fuel may deteriorate painted surfaces or plastic parts.**<sup>[ECA10072]</sup>
4. Be sure to securely close the fuel tank cap.

EWA15152



**WARNING**

**Gasoline is poisonous and can cause injury or death. Handle gasoline with care. Never siphon gasoline by mouth. If you should swallow some gasoline or inhale a lot of gasoline vapor, or get some gasoline in**

**your eyes, see your doctor immediately. If gasoline spills on your skin, wash with soap and water. If gasoline spills on your clothing, change your clothes.**

EAU86081

Your Yamaha engine was designed to use unleaded gasoline with a research octane number of 95 or higher. If engine knocking or pinging occurs, use a gasoline of a different brand or higher octane rating.

### Recommended fuel:

Unleaded gasoline (E10 acceptable)

### Octane number (RON):

95

### Fuel tank capacity:

19 L (5.0 US gal, 4.2 Imp.gal)

### Fuel tank reserve:

3.7 L (0.98 US gal, 0.81 Imp.gal)

## Gasohol

There are two types of gasohol: gasohol containing ethanol and that containing methanol. Gasohol containing ethanol can be used if the ethanol content does not exceed 10% (E10).

# Instrument and control functions

Gasohol containing methanol is not recommended by Yamaha because it can cause damage to the fuel system or vehicle performance problems.

ECA11401

## NOTICE

**Use only unleaded gasoline. The use of leaded gasoline will cause severe damage to internal engine parts, such as the valves and piston rings, as well as to the exhaust system.**

6

## Fuel tank overflow hose

EAU86161

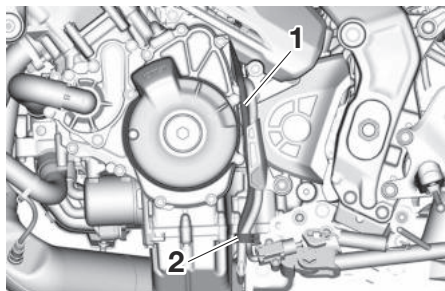

1. Fuel tank overflow hose
2. Clamp

The overflow hose drains excess gasoline and directs it safely away from the vehicle.

Before operating the vehicle:

- Check the fuel tank overflow hose connection.
- Check the fuel tank overflow hose for cracks or damage, and replace it if necessary.
- Make sure that the fuel tank overflow hose is not blocked, and clean it if necessary.
- Make sure that the fuel tank overflow hose is positioned as shown.

## TIP

See page 9-9 for canister information.

## Catalytic converter

EAU13435

The exhaust system contains catalytic converter(s) to reduce harmful exhaust emissions.

EWA10863



### WARNING

The exhaust system is hot after operation. To prevent a fire hazard or burns:

- Do not park the vehicle near possible fire hazards such as grass or other materials that easily burn.
- Park the vehicle in a place where pedestrians or children are not likely to touch the hot exhaust system.
- Make sure that the exhaust system has cooled down before doing any maintenance work.
- Do not allow the engine to idle more than a few minutes. Long idling can cause a build-up of heat.

## Seats

EAU92640

### Passenger seat

#### To remove the passenger seat

1. Insert the key into the seat lock, and then turn it counterclockwise.

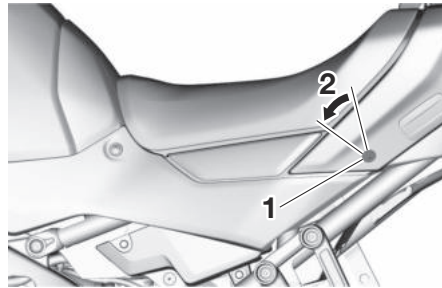

1. Seat lock
2. Unlock.

2. Lift the front of the passenger seat and pull it forward.

#### To install the passenger seat

1. Insert the projections on the rear of the passenger seat into the seat holders as shown, and then push the front of the seat down to lock it in place.

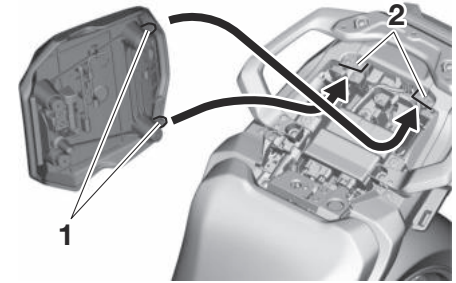

1. Projection
2. Seat holder

2. Remove the key.

### Rider seat

#### To remove the rider seat

1. Remove the passenger seat.
2. Remove the cap, then push the rider seat lock lever, located under the back of the rider seat, to the left as shown, and then pull the seat off.

# Instrument and control functions

EAU63051

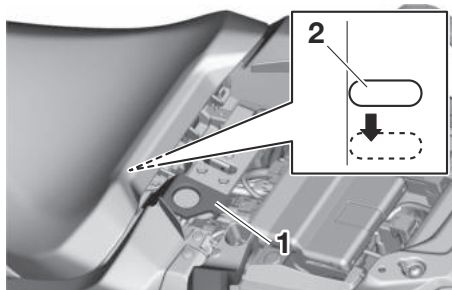

1. Cap
2. Rider seat lock lever

2. Seat holder
2. Install the cap.

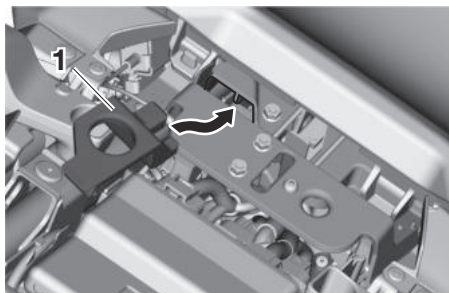

1. Cap
3. Install the passenger seat.

## TIP

- Make sure that the seats are properly secured before riding.
- The rider seat height can be adjusted. See the following section.

## Adjusting the rider seat height

The rider seat height can be adjusted to one of two positions. At factory assembly the rider seat height is set to the low position.

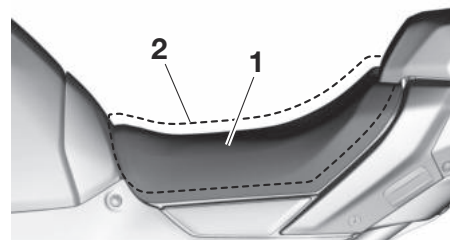

1. Low position
2. High position

## To change to the high position

1. Remove the passenger seat and rider seat.
2. Remove the rider seat height position adjuster by pulling it upward.

## To install the rider seat

1. Insert the projection on the front of the rider seat into the seat holder as shown, and then push the rear of the seat down to lock it in place.

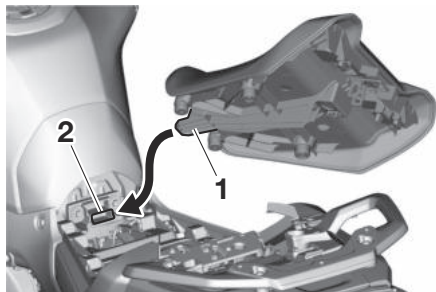

1. Projection

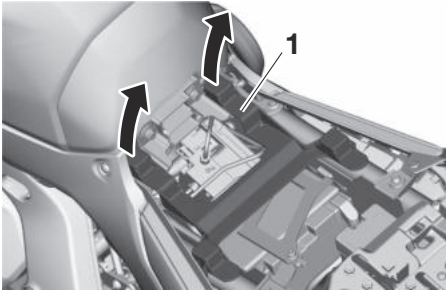

1. Rider seat height position adjuster

3. Install the rider seat height position adjuster by inserting the front projections into the grommets.

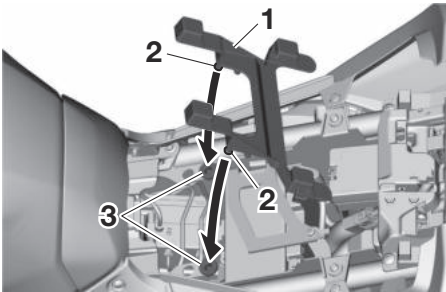

1. Rider seat height position adjuster  
2. Projection  
3. Grommet

4. Insert the projection on the front of the rider seat into seat holder B as shown.

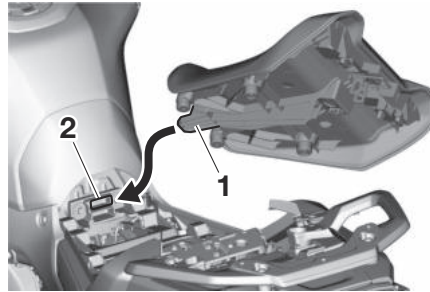

1. Projection  
2. Seat holder B (for high position)

5. Align the projection on the bottom of the rider seat with the “H” position slot, and then push the rear of the seat down to lock it in place as shown.

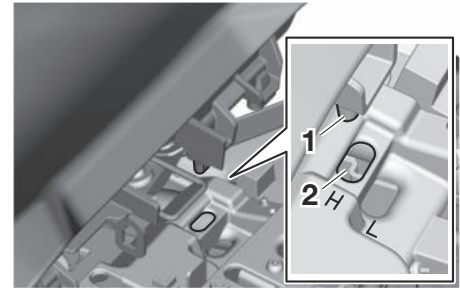

1. Projection  
2. “H” position slot

6. Install the passenger seat.

## To change to the low position

1. Remove the passenger seat and rider seat.
2. Remove the rider seat height position adjuster by pulling it upward.
3. Install the rider seat height position adjuster by inserting the rear projections into the grommets.

# Instrument and control functions

EAU91560

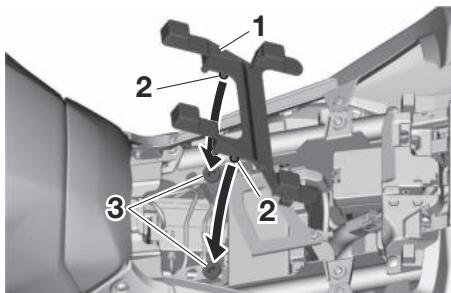

1. Rider seat height position adjuster
2. Projection
3. Grommet

4. Insert the projection on the front of the rider seat into seat holder A as shown.

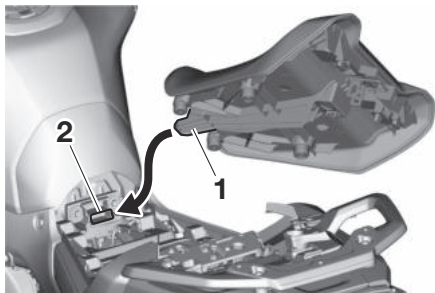

1. Projection
2. Seat holder A (for low position)

5. Align the projection on the bottom of the rider seat with the “L” position slot, and then push the rear of the seat down to lock it in place as shown.



1. Projection
2. “L” position slot

6. Install the passenger seat.

## TIP

Make sure that the seats are properly secured before riding.

## Rider footrest position

The rider footrests can be adjusted to one of two positions. From the factory, the footrests are in the low position. Have a Yamaha dealer adjust the positions of the rider footrests.

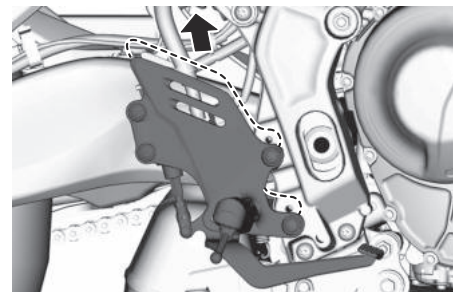
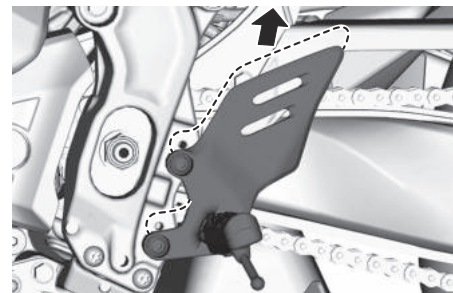

## Storage compartment

EUA5953

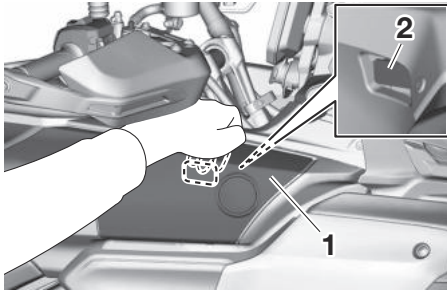

1. Storage compartment lid
2. Button

Press the button located on the backside of the storage compartment to open the storage compartment lid.

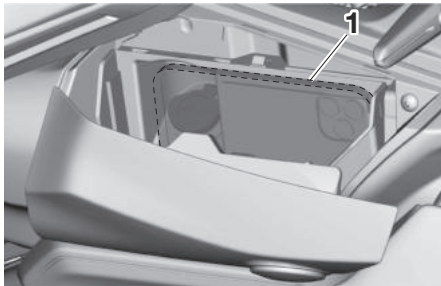

1. Smartphone

Store smartphones as shown.

Smartphones can be charged by connecting them to the USB jack also located in the compartment. (See page 6-51.)

### TIP

Be careful not to pinch your smartphone cable in the lid.

ECA28830

### NOTICE

- The storage compartment accumulates heat when exposed to the sun. Do not store smartphones or anything else susceptible to heat damage, consumables or flammable items inside the compartment. Smartphones may not work properly when exposed to excessive heat.
- To protect your smartphone from damage while it is in the storage compartment: Do not put metal items, tools, or sharply edged items directly in the storage compartment. If these items must be stored, wrap them in appropriate cushioning material.

- Yamaha shall not be liable for any damage incurred to smartphone devices.

EWA20970

### ⚠ WARNING

- Do not exceed the load limit of 0.5 kg (1 lb) for the storage compartment.
- Do not exceed the maximum load of 197 kg (434 lb) for the vehicle.

# Instrument and control functions

## Handlebar position

EAU46833

The handlebar can be adjusted to one of two positions to suit the rider's preference. Have a Yamaha dealer adjust the position of the handlebar.



6

## Sidescase support holder

EAU99581

This vehicle is equipped with sidescase support holders. Consult your Yamaha dealer before installing any sidescases.

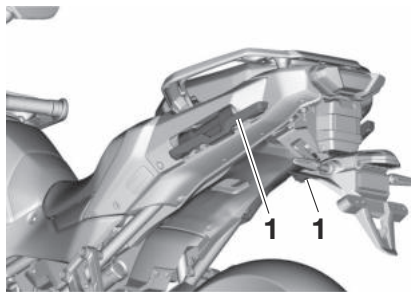

1. Sidescase support holder

## Adjusting the front and rear suspension

EAU0643

This model is equipped with an electronically controlled suspension damping system (KADS). See pages 4-25 and 6-33 for more information on KADS and YRC settings related to the suspension.

### TIP

After any service to the rear suspension, a sensor calibration must be performed using the pop-up menu system. See page 6-36 for more information on SUS Sensor Calibration.

## Spring preload of the front fork

EWA10181

### **! WARNING**

Always adjust both fork legs equally, otherwise poor handling and loss of stability may result.

### **NOTICE**

ECA27260

Use extra care to avoid scratching the anodized finish when making suspension adjustments.

Turn the adjuster in direction (a) to increase the spring preload.

Turn the adjuster in direction (b) to decrease the spring preload.

To set the spring preload, turn the adjuster in direction (b) until it stops, and then count the turns in direction (a).

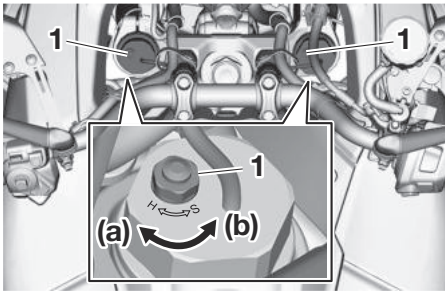

1. Spring preload adjuster

### Spring preload setting:

Minimum (soft):

0 turn(s) in direction (a)

Standard:

2 turn(s) in direction (a)

Maximum (hard):

10 turn(s) in direction (a)

## Spring preload of the shock absorber assembly

EWA10222



**This shock absorber assembly contains highly pressurized nitrogen gas. Read and understand the following information before handling the shock absorber assembly.**

- Do not tamper with or attempt to open the cylinder assembly.
- Do not subject the shock absorber assembly to an open flame or other high heat source. This may cause the unit to explode due to excessive gas pressure.
- Do not deform or damage the cylinder in any way. Cylinder damage will result in poor damping performance.
- Do not dispose of a damaged or worn-out shock absorber assembly yourself. Take the shock absorber assembly to a Yamaha dealer for any service.

Turn the adjuster in direction (a) to increase the spring preload.

Turn the adjuster in direction (b) to decrease the spring preload.

To set the spring preload, turn the adjuster in direction (b) until it stops, and then count the clicks in direction (a).

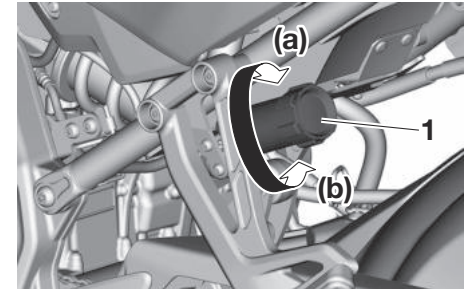

1. Spring preload adjuster

### Spring preload setting:

Minimum (soft):

1 click(s) in direction (a)

Standard:

13 click(s) in direction (a)

Maximum (hard):

24 click(s) in direction (a)

### TIP

When turning the spring preload adjuster in direction (b), the 0 click position and the 1 click position may be the same.

# Instrument and control functions

EAU70642

## DC connectors

This vehicle is equipped with additional wiring and DC connector(s) for the installation of optional electric accessories.

Consult a Yamaha dealer for more information regarding the location and capacity of the DC connector(s) and about what accessories are capable of being installed.

EAU4413

## USB jack(s)

The 5V USB jack can be used when the main switch is on.

### TIP

- Do not use the USB jack when the engine is off or it will drain the battery.
- Under some conditions, the device battery level may drop even while the USB is plugged in.

### Handlebar area:

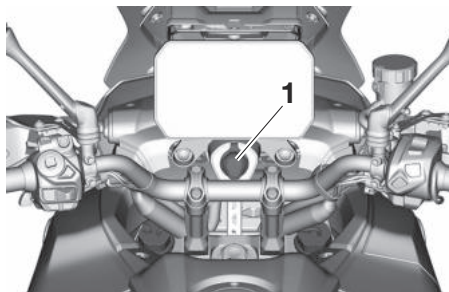

1. USB jack cap

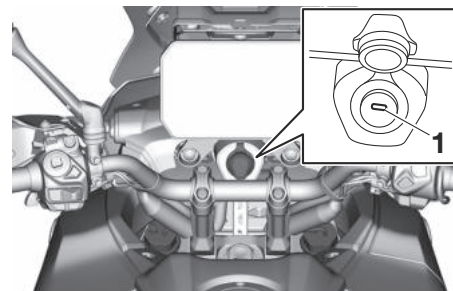

1. USB Type-C jack

### Storage compartment :

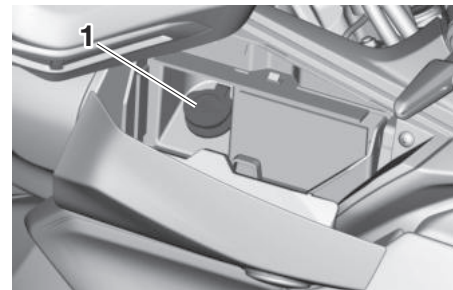

1. USB jack cap

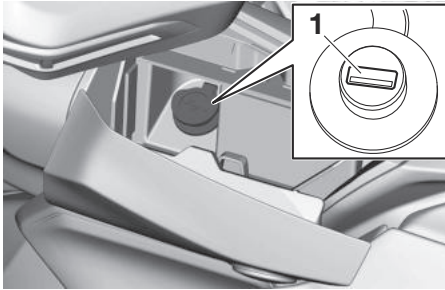

1. USB Type-A jack

ECA28780

## NOTICE

- To protect the USB jack from water and collisions, install the cap when the jack is not being used.
- To prevent damage, avoid applying excessive force when opening and closing the USB jack cap.
- Ensure the USB jack cap is properly installed and do not use the USB jack when it rains or when washing the vehicle. If the USB jack gets wet, please dry it with the vehicle turned off before using it.

- Do not put tension or apply force to cables attached to the USB jack as it may cause damage.

## Sidestand

The sidestand is located on the left side of the frame. Raise the sidestand or lower it with your foot while holding the vehicle upright.

### TIP

The built-in sidestand switch is part of the ignition circuit cut-off system, which cuts the ignition in certain situations. (See the following section for an explanation of the ignition circuit cut-off system.)

EWA10242

## ⚠ WARNING

The vehicle must not be ridden with the sidestand down, or if the sidestand cannot be properly moved up (or does not stay up), otherwise the sidestand could contact the ground and distract the operator, resulting in a possible loss of control. Yamaha's ignition circuit cut-off system has been designed to assist the operator in fulfilling the responsibility of raising the sidestand before starting off. Therefore, check this system regularly and have a Yamaha

# Instrument and control functions

---

dealer repair it if it does not function properly.

---

EAUJ6260

## Ignition circuit cut-off system

This system prevents engine starts unless the sidestand is up and the brakes are applied. Also, it will stop the running engine should the sidestand be lowered.

Periodically check the system via the following procedure.

### TIP

---

- This check is most reliable if performed with a warmed-up engine.
  - See pages 4-37 and 6-1 for switch operation information.
-

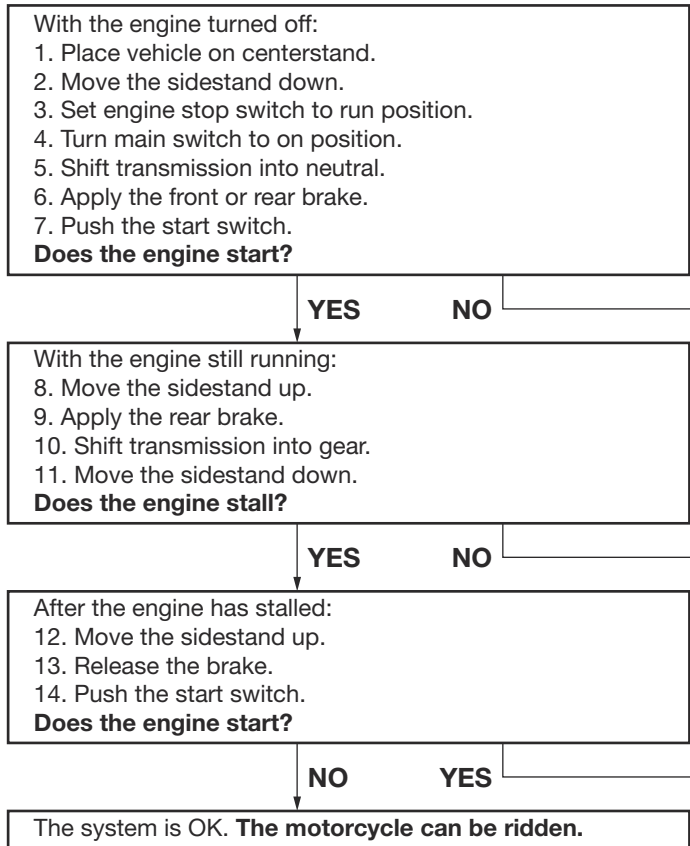

## **⚠ WARNING**

- **The vehicle must be placed on the centerstand during this inspection.**
- **If a malfunction is found, have the vehicle inspected before riding.**

The neutral switch, a brake light switch or the Y-AMT system may not be working.  
**The motorcycle should not be ridden** until checked by a Yamaha dealer.

The sidestand switch may not be working.  
**The motorcycle should not be ridden** until checked by a Yamaha dealer.

A brake light switch may not be working.  
**The motorcycle should not be ridden** until checked by a Yamaha dealer.

# For your safety – pre-operation checks

EAU1559B

Inspect your vehicle each time you use it to make sure the vehicle is in safe operating condition. Always follow the inspection and maintenance procedures and schedules described in the Owner's Manual.

EWA11152

## **WARNING**

**Failure to inspect or maintain the vehicle properly increases the possibility of an accident or equipment damage. Do not operate the vehicle if you find any problem. If a problem cannot be corrected by the procedures provided in this manual, have the vehicle inspected by a Yamaha dealer.**

Before using this vehicle, check the following points:

ITEM	CHECKS	PAGE
<b>Fuel</b>	<ul style="list-style-type: none"><li>• Check fuel level in fuel tank.</li><li>• Refuel if necessary.</li><li>• Check fuel line for leakage.</li><li>• Check fuel tank overflow hose for obstructions, cracks or damage, and check hose connection.</li></ul>	6-42, 6-43
<b>Engine oil</b>	<ul style="list-style-type: none"><li>• Check oil level in engine.</li><li>• If necessary, add recommended oil to specified level.</li><li>• Check vehicle for oil leakage.</li></ul>	9-9
<b>Coolant</b>	<ul style="list-style-type: none"><li>• Check coolant level in reservoir.</li><li>• If necessary, add recommended coolant to specified level.</li><li>• Check cooling system for leakage.</li></ul>	9-12
<b>Front brake</b>	<ul style="list-style-type: none"><li>• Check operation.</li><li>• If soft or spongy, have Yamaha dealer bleed hydraulic system.</li><li>• Check brake pads for wear.</li><li>• Replace if necessary.</li><li>• Check fluid level in reservoir.</li><li>• If necessary, add specified brake fluid to specified level.</li><li>• Check hydraulic system for leakage.</li></ul>	9-18, 9-18

# For your safety – pre-operation checks

ITEM	CHECKS	PAGE
<b>Rear brake</b>	<ul style="list-style-type: none"> <li>• Check operation.</li> <li>• If soft or spongy, have Yamaha dealer bleed hydraulic system.</li> <li>• Check brake pads for wear.</li> <li>• Replace if necessary.</li> <li>• Check fluid level in reservoir.</li> <li>• If necessary, add specified brake fluid to specified level.</li> <li>• Check hydraulic system for leakage.</li> </ul>	9-18, 9-18
<b>Throttle grip</b>	<ul style="list-style-type: none"> <li>• Check for smooth rotation and automatic return.</li> </ul>	9-23
<b>Control cables</b>	<ul style="list-style-type: none"> <li>• Make sure that operation is smooth.</li> <li>• Lubricate if necessary.</li> </ul>	9-22
<b>Drive chain</b>	<ul style="list-style-type: none"> <li>• Check chain slack.</li> <li>• Adjust if necessary.</li> <li>• Check chain condition.</li> <li>• Lubricate if necessary.</li> </ul>	9-20, 9-22
<b>Wheels and tires</b>	<ul style="list-style-type: none"> <li>• Check for damage.</li> <li>• Check tire condition and tread depth.</li> <li>• Check air pressure.</li> <li>• Correct if necessary.</li> </ul>	9-14, 9-16
<b>Brake pedal</b>	<ul style="list-style-type: none"> <li>• Make sure that operation is smooth.</li> <li>• Lubricate pedal pivoting point if necessary.</li> </ul>	9-23
<b>Brake lever</b>	<ul style="list-style-type: none"> <li>• Make sure that operation is smooth.</li> <li>• Lubricate lever pivoting point if necessary.</li> </ul>	9-23
<b>Centerstand, sidestand</b>	<ul style="list-style-type: none"> <li>• Make sure that operation is smooth.</li> <li>• Lubricate pivots if necessary.</li> </ul>	9-24
<b>Chassis fasteners</b>	<ul style="list-style-type: none"> <li>• Make sure that all nuts, bolts and screws are properly tightened.</li> <li>• Tighten if necessary.</li> </ul>	—
<b>Instruments, lights, signals and switches</b>	<ul style="list-style-type: none"> <li>• Check operation.</li> <li>• Correct if necessary.</li> </ul>	—
<b>Sidestand switch</b>	<ul style="list-style-type: none"> <li>• Check operation of ignition circuit cut-off system.</li> <li>• If system is not working correctly, have Yamaha dealer check vehicle.</li> </ul>	6-52

# Operation and important riding points

---

EAU15952

Read the Owner's Manual carefully to become familiar with all controls. If there is a control or function you do not understand, ask your Yamaha dealer.

EWA10272

## **WARNING**

**Failure to familiarize yourself with the controls can lead to loss of control, which could cause an accident or injury.**

---

8

## Engine break-in

EAU16842

There is never a more important period in the life of your engine than the period between 0 and 1600 km (1000 mi). For this reason, you should read the following material carefully.

Since the engine is brand new, do not put an excessive load on it for the first 1600 km (1000 mi). The various parts in the engine wear and polish themselves to the correct operating clearances. During this period, prolonged full-throttle operation or any condition that might result in engine overheating must be avoided.

EAU17094

## 0–1000 km (0–600 mi)

Avoid prolonged operation above 5300 r/min. **NOTICE:** After 1000 km (600 mi) of operation, the engine oil must be changed and the oil filter cartridge or element replaced.<sup>[ECA10303]</sup>

## 1000–1600 km (600–1000 mi)

Avoid prolonged operation above 6300 r/min.

## 1600 km (1000 mi) and beyond

The vehicle can now be operated normally.

ECA10311

## **NOTICE**

- Keep the engine speed out of the tachometer red zone.
  - If any engine trouble should occur during the engine break-in period, immediately have a Yamaha dealer check the vehicle.
-

## Starting the engine

### To start the engine

1. With the smart key turned on, approach the vehicle.
2. Turn the main switch on and set the engine stop switch to the run position.
3. Confirm the indicator and warning light(s) come on for a few seconds, and then go off. (See page 6-4.)

### TIP

- Do not start the engine if the engine trouble warning light or the Y-AMT malfunction indicator light remains on.
- The oil pressure warning icon should come on and stay on until the engine is started.
- The ABS warning light should come on and stay on until the vehicle reaches a speed of 5 km/h (3 mi/h).
- The UBS warning light should come on and stay on until the vehicle reaches a speed of 5 km/h (3 mi/h).

### NOTICE

**If a warning or indicator light does not work as described above, have a Yamaha dealer check the vehicle.**

4. Close the throttle completely.
5. Start the engine by applying the brakes and then pushing the start switch.
6. Release the start switch when the engine starts, or after 5 seconds. Wait 10 seconds before pressing the switch again to allow battery voltage to restore.

### TIP

- If the engine fails to start, try again with the transmission in neutral and the throttle grip turned by a 1/4 turn (20 degrees) open.
- To avoid unintended acceleration, the Y-AMT prevents the vehicle from accelerating if the engine is started with the throttle grip turned open. Return the throttle grip to the closed position and when the engine r/min has decreased, the vehicle can then accelerate.

### WARNING

**Do not push the vehicle while the engine is running. Unintentional rotation of the throttle grip and/or accidental pressing of the shift lever may result in accidents.**

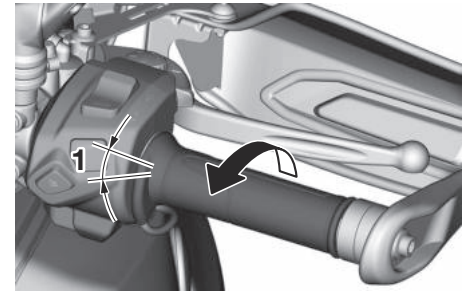

1. 1/4 turn (20 degrees)

### NOTICE

**For maximum engine life, never accelerate hard when the engine is cold!**

# Operation and important riding points

EAU68221

EAU0073

EAU2803

## TIP

This model is equipped with:

- an inertial measurement unit (IMU). This unit stops the engine in case of a turnover. Turn the main switch off and then on before attempting to restart the engine. Failing to do so will prevent the engine from starting even though the engine will crank when pushing the start switch.
- an engine auto-stop system. The engine stops automatically if left idling for 20 minutes. If the engine stops, simply push the start switch to restart the engine.

## NOTICE

**Do not ride through deep water, otherwise the engine may be damaged. Avoid puddles because they may be deeper than expected.**

ECAN0072

## Shifting

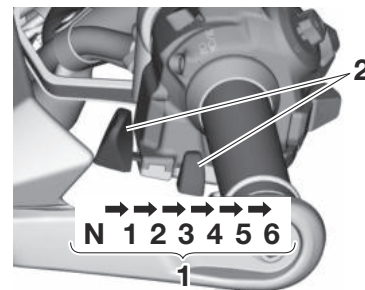

1. Gear positions
2. Shift lever

The Yamaha-Automated Manual Transmission (Y-AMT) equipped on this vehicle can shift gears manually in both “AT” and “MT” mode by using the shift lever (see page 6-3). The order of the gear positions is as shown in the above image. The gear positions are shown in the illustration.

## TIP

The Y-AMT requires the vehicle power to be on in order to shift gears.

- To engage the neutral position in the transmission, repeatedly press the shift lever in the “\_” direction

until the neutral indicator light comes on.

- When shifting from neutral to 1st gear, ensure the engine speed remains below approximately 1800 r/min, and the sidestand is in the up position.
- Upshifting is not possible if the engine speed is too low.
- Downshifting is not possible if the engine speed is too high.
- The transmission automatically downshifts to 1st gear and engages the clutch when the vehicle comes to a stop.
- When the vehicle power is turned on in gear, the gears cannot be shifted until either the brake lever or pedal is pressed.

ECA28590

## NOTICE

**Even with the transmission in the neutral position, do not coast for long periods of time with the engine off, nor tow the motorcycle for long distances. The transmission is properly lubricated only when the engine**

**is running. Inadequate lubrication may damage the transmission.**

EUAU2810

## To start out and accelerate

1. If the transmission is in neutral, shift the transmission into first gear. The neutral indicator light should go out.
2. Open the throttle gradually.
3. If using “MT” mode, shift the transmission into second gear and then higher gears accordingly.

EUAU2821

## To decelerate and stop

1. Release the throttle and apply both the front and the rear brakes smoothly to slow the motorcycle.
2. As the vehicle decelerates, shift to a lower gear (if in MT mode).
3. Once the motorcycle has stopped, the Y-AMT will automatically downshift the vehicle into 1st gear. The transmission can then be shifted into the neutral position if desired.

## WARNING

- **Improper braking can cause loss of control or traction. Always use both brakes and apply them smoothly.**
- **Make sure that the motorcycle and the engine have sufficiently slowed before shifting to a lower gear. Engaging a lower gear when the vehicle or engine speed is too high could make the rear wheel lose traction or the engine to over-rev. This could cause loss of control, an accident and injury. It could also cause engine or drive train damage.**

EWA17380

ECA12682

## NOTICE

- **Use the brake when stopping on an uphill slope. Holding the vehicle at a stop with throttle operation will cause the clutch to heat up, causing damage to the clutch.**

# Operation and important riding points

---

- Do not rev the throttle unnecessarily, otherwise the malfunction indicator light (MIL)/engine trouble warning light may come on.
- 

## Tips for reducing fuel consumption

EAU16811

Fuel consumption depends largely on your riding style. Consider the following tips to reduce fuel consumption:

- Shift up swiftly, and avoid high engine speeds during acceleration.
- Do not rev the engine while shifting down, and avoid high engine speeds with no load on the engine.
- Turn the engine off instead of letting it idle for an extended length of time (e.g., in traffic jams, at traffic lights or at railroad crossings).

## Parking

EAU2401

When parking, turn the main switch off and then turn the smart key off.

### TIP

After 1 second of being stopped in 1st gear with the vehicle power off, the Y-AMT will engage the clutch so the vehicle cannot roll freely. If you wish to turn the power off and then roll the vehicle in neutral, shift into neutral before turning off the main switch.

If the sidestand is lowered when the engine is running (except neutral), the engine will stop and the beeper will sound to prevent you from forgetting to turn off the vehicle power. To stop the beeper, turn the vehicle power off or raise the sidestand.

When leaving the vehicle, make sure you apply the steering lock. Take the smart key with you.

### TIP

- After parking, if the smart key is not turned off and is within operating range, other people may be able to start the engine and operate the vehicle.

- The alarm beeper can be set to not activate. Contact your Yamaha dealer.

EWA10312

## **WARNING**

- Since the engine and exhaust system can become very hot, park in a place where pedestrians or children are not likely to touch them and be burned.
- Do not park on a slope or on soft ground, otherwise the vehicle may overturn, increasing the risk of a fuel leak and fire.
- Do not park near grass or other flammable materials which might catch fire.

# Periodic maintenance and adjustment

---

EUA2951

Periodic inspection, adjustment, and lubrication will keep your vehicle in the safest and most efficient condition possible. Safety is an obligation of the vehicle owner/operator. The most important points of vehicle inspection, adjustment, and lubrication are explained on the following pages.

The intervals given in the periodic maintenance charts should be simply considered as a general guide under normal riding conditions. However, depending on the weather, terrain, geographical location, and individual use, the maintenance intervals may need to be shortened.

EWA10322

## **WARNING**

Failure to properly maintain the vehicle or performing maintenance activities incorrectly may increase your risk of injury or death during service or while using the vehicle. If you are not familiar with vehicle service, have a Yamaha dealer perform service.

---

EWA22761

## **WARNING**

Turn off the engine when performing maintenance unless otherwise specified.

- A running engine has moving parts that can catch on body parts or clothing and electrical parts that can cause shocks or fires.
- Running the engine while servicing can lead to eye injury, burns, fire, or carbon monoxide poisoning – possibly leading to death. See page 2-2 for more information about carbon monoxide.
- Even with the engine off, some of the Y-AMT components can move unintentionally with only the vehicle power on. These components can pinch body parts and/or clothing, causing serious injury.

EWA15461

## **WARNING**

Brake discs, calipers, drums, and linings can become very hot during

use. To avoid possible burns, let brake components cool before touching them.

---

EAU17303

Emission controls not only function to ensure cleaner air, but are also vital to proper engine operation and maximum performance. In the following periodic maintenance charts, the services related to emissions control are grouped separately. These services require specialized data, knowledge, and equipment. Maintenance, replacement, or repair of the emission control devices and systems may be performed by any repair establishment or individual that is certified (if applicable). Yamaha dealers are trained and equipped to perform these particular services.

## Tool kits

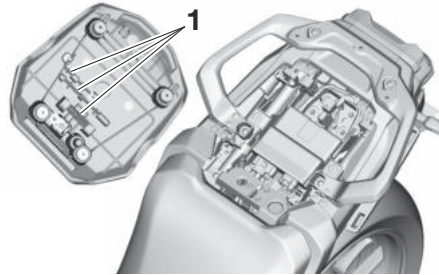

EAU85240

### 1. Tool kit

The on-board tool kit is in the location shown. Also, an additional tool kit was handed out separately at the time of vehicle purchase.

The information included in this manual and the tools provided in the tool kits are intended to assist you in the performance of preventive maintenance and minor repairs. However, a torque wrench and other tools are necessary to perform certain maintenance work correctly.

## TIP

If you do not have the tools or experience required for a particular job, have your Yamaha dealer perform it for you.

# Periodic maintenance and adjustment

EAU91891

## TIP

- The annual checks must be performed every year, except if a kilometer-based maintenance is performed instead.
- For 31000 km or 30 months, repeat the maintenance intervals starting from 7000 km or 6 months.
- Items marked with an asterisk require special tools, data and technical skills, have a Yamaha dealer perform the service.

EAU91902

## Periodic maintenance chart for the emission control system

No.	ITEM	ROUTINE	INITIAL	ODOMETER READINGS					ANNUAL CHECK
			1000 km or 1 month	7000 km or 6 months	13000 km or 12 months	19000 km or 18 months	25000 km or 24 months		
1	* Fuel line	<ul style="list-style-type: none"> <li>• Check fuel hoses for cracks or damage.</li> <li>• Replace if necessary.</li> </ul>		√	√	√	√	√	
2	* Spark plugs	<ul style="list-style-type: none"> <li>• Check condition.</li> <li>• Adjust gap and clean.</li> <li>• Replace.</li> </ul>		√					
			Every 19000 km (12000 mi) or 18 months						
3	* Valve clearance	<ul style="list-style-type: none"> <li>• Check and adjust valve clearance when engine is cold.</li> </ul>	Every 42000 km (26600 mi)						
4	* Fuel injection	<ul style="list-style-type: none"> <li>• Check engine idle speed.</li> <li>• Check and adjust synchronization.</li> </ul>	√	√	√	√	√	√	
5	* Exhaust system	<ul style="list-style-type: none"> <li>• Check for leakage.</li> <li>• Tighten if necessary.</li> <li>• Replace gasket(s) if necessary.</li> </ul>		√	√	√	√		
6	* Evaporative emission control system	<ul style="list-style-type: none"> <li>• Check control system for damage.</li> <li>• Replace if necessary.</li> </ul>			√		√		

# Periodic maintenance and adjustment

EAU92131

## General maintenance and lubrication chart

No.	ITEM	ROUTINE	INITIAL	ODOMETER READINGS					ANNUAL CHECK
			1000 km or 1 month	7000 km or 6 months	13000 km or 12 months	19000 km or 18 months	25000 km or 24 months		
1	* Diagnostic system check	<ul style="list-style-type: none"> <li>Perform dynamic inspection using Yamaha diagnostic tool.</li> <li>Check the error codes.</li> </ul>	√	√	√	√	√	√	
2	* Air filter element	<ul style="list-style-type: none"> <li>Replace.</li> </ul>	Every 40000 km (24000 mi)						
3	* Front brake	<ul style="list-style-type: none"> <li>Check operation, fluid level, and for fluid leakage.</li> <li>Replace brake pads if necessary.</li> </ul>	√	√	√	√	√	√	
4	* Rear brake	<ul style="list-style-type: none"> <li>Check operation, fluid level, and for fluid leakage.</li> <li>Replace brake pads if necessary.</li> </ul>	√	√	√	√	√	√	
5	* Brake hoses	<ul style="list-style-type: none"> <li>Check for cracks or damage.</li> <li>Check for correct routing and clamping.</li> </ul>		√	√	√	√	√	
		<ul style="list-style-type: none"> <li>Replace.</li> </ul>	Every 4 years						
6	* Brake fluid	<ul style="list-style-type: none"> <li>Change.</li> </ul>	Every 2 years						
7	* Wheels	<ul style="list-style-type: none"> <li>Check runout and for damage.</li> <li>Replace if necessary.</li> </ul>		√	√	√	√		
8	* Tires	<ul style="list-style-type: none"> <li>Check tread depth and for damage.</li> <li>Replace if necessary.</li> <li>Check air pressure.</li> <li>Correct if necessary.</li> </ul>		√	√	√	√	√	
9	* Wheel bearings	<ul style="list-style-type: none"> <li>Check bearings for looseness or damage.</li> </ul>		√	√	√	√		
10	* Swingarm pivot bearings	<ul style="list-style-type: none"> <li>Check operation and for excessive play.</li> </ul>		√	√	√	√		
		<ul style="list-style-type: none"> <li>Lubricate with lithium-soap-based grease.</li> </ul>	Every 50000 km (30000 mi)						

# Periodic maintenance and adjustment

No.	ITEM	ROUTINE	INITIAL	ODOMETER READINGS					ANNUAL CHECK
			1000 km or 1 month	7000 km or 6 months	13000 km or 12 months	19000 km or 18 months	25000 km or 24 months		
11	Drive chain	<ul style="list-style-type: none"> <li>Check chain slack, alignment and condition.</li> <li>Adjust and lubricate chain with a special O-ring chain lubricant thoroughly.</li> </ul>	Every 1000 km (600 mi) and after washing the motorcycle, riding in the rain or riding in wet areas						
12	* Steering bearings	<ul style="list-style-type: none"> <li>Check bearing assemblies for looseness.</li> <li>Moderately repack with lithium-soap-based grease.</li> </ul>	√	√	√	√	√	Every 19000 km (12000 mi)	
13	* Chassis fasteners	<ul style="list-style-type: none"> <li>Make sure that all nuts, bolts and screws are properly tightened.</li> </ul>		√	√	√	√	√	
14	Brake lever pivot shaft	<ul style="list-style-type: none"> <li>Lubricate with silicone grease.</li> </ul>		√	√	√	√	√	
15	Brake pedal pivot shaft	<ul style="list-style-type: none"> <li>Lubricate with lithium-soap-based grease.</li> </ul>		√	√	√	√	√	
16	Sidestand	<ul style="list-style-type: none"> <li>Check operation.</li> <li>Lubricate with molybdenum disulfide grease.</li> </ul>		√	√	√	√	√	
17	Centerstand	<ul style="list-style-type: none"> <li>Check operation.</li> <li>Lubricate with lithium-soap-based grease.</li> </ul>		√	√	√	√	√	
18	* Sidestand switch	<ul style="list-style-type: none"> <li>Check operation and replace if necessary.</li> </ul>	√	√	√	√	√	√	
19	* Front fork	<ul style="list-style-type: none"> <li>Check operation and for oil leakage.</li> <li>Replace if necessary.</li> </ul>		√	√	√	√		
20	* Shock absorber assembly	<ul style="list-style-type: none"> <li>Check operation and for oil leakage.</li> <li>Replace if necessary.</li> </ul>		√	√	√	√		

# Periodic maintenance and adjustment

No.	ITEM	ROUTINE	INITIAL	ODOMETER READINGS					ANNUAL CHECK
			1000 km or 1 month	7000 km or 6 months	13000 km or 12 months	19000 km or 18 months	25000 km or 24 months		
21	* Rear suspension relay arm and connecting arm pivoting points	<ul style="list-style-type: none"> <li>• Check operation.</li> </ul>		√	√	√	√		
22	Engine oil	<ul style="list-style-type: none"> <li>• Change.</li> <li>• Check oil level and vehicle for oil leakage.</li> </ul>	√	√	√	√	√	√	
23	Engine oil filter cartridge	<ul style="list-style-type: none"> <li>• Replace.</li> </ul>	√		√		√		
24	* Cooling system	<ul style="list-style-type: none"> <li>• Check coolant level and vehicle for coolant leakage.</li> </ul>		√	√	√	√	√	
		<ul style="list-style-type: none"> <li>• Change with Yamaha genuine coolant.</li> </ul>	Every 3 years						
25	* Front and rear brake switches	<ul style="list-style-type: none"> <li>• Check operation.</li> </ul>	√	√	√	√	√	√	
26	Moving parts and cables	<ul style="list-style-type: none"> <li>• Lubricate.</li> </ul>		√	√	√	√	√	
27	* Throttle grip	<ul style="list-style-type: none"> <li>• Check operation.</li> <li>• Lubricate throttle grip housing tube guides.</li> </ul>		√	√	√	√	√	
28	* Lights, signals and switches	<ul style="list-style-type: none"> <li>• Check operation.</li> <li>• Adjust headlight beam.</li> </ul>	√	√	√	√	√	√	

EAUJ0770

## TIP

- Air filter
  - This model's air filter is equipped with a disposable oil-coated paper element, which must not be cleaned with compressed air to avoid damaging it.

# Periodic maintenance and adjustment

---

- The air filter element needs to be replaced more frequently when riding in unusually wet or dusty areas.
  - Hydraulic brake service
    - Regularly check and, if necessary, correct the brake fluid level.
    - Every two years replace the internal components of the brake master cylinders and calipers, and change the brake fluid.
    - Replace the brake hoses every four years and if cracked or damaged.
  - Battery service
    - Check the condition and service the battery in every periodic maintenance.
    - Recharge the battery immediately if the voltage is less than 12.8 V.
    - If the battery does not hold a charge, replace it immediately.
-

# Periodic maintenance and adjustment

EAU19653

## Checking the spark plugs

The spark plugs are important engine components, which should be checked periodically, preferably by a Yamaha dealer. Since heat and deposits will cause any spark plug to slowly erode, they should be removed and checked in accordance with the periodic maintenance and lubrication chart. In addition, the condition of the spark plugs can reveal the condition of the engine.

The porcelain insulator around the center electrode of each spark plug should be a medium-to-light tan (the ideal color when the vehicle is ridden normally), and all spark plugs installed in the engine should have the same color. If any spark plug shows a distinctly different color, the engine could be operating improperly. Do not attempt to diagnose such problems yourself. Instead, have a Yamaha dealer check the vehicle.

If a spark plug shows signs of electrode erosion and excessive carbon or other deposits, it should be replaced.

**Specified spark plug:**  
NGK/LMAR9A-9

Before installing a spark plug, the spark plug gap should be measured with a wire thickness gauge and, if necessary, adjusted to specification.

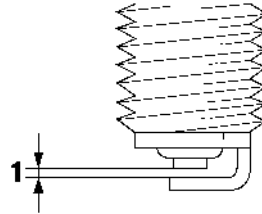

1. Spark plug gap

### Spark plug gap:

0.8–0.9 mm (0.031–0.035 in)

Clean the surface of the spark plug gasket and its mating surface, and then wipe off any grime from the spark plug threads.

### Tightening torque:

Spark plug:

13 N·m (1.3 kgf·m, 9.6 lb·ft)

## TIP

If a torque wrench is not available when installing a spark plug, a good estimate of the correct torque is 1/4–1/2 turn past finger tight. However, the spark plug should be tightened to the specified torque as soon as possible.

ECA10841

## NOTICE

**Do not use any tools to remove or install the spark plug cap, otherwise the ignition coil coupler may get damaged. The spark plug cap may be difficult to remove because the rubber seal on the end of the cap fits tightly. To remove the spark plug cap, simply twist it back and forth while pulling it out; to install it, twist it back and forth while pushing it in.**

# Periodic maintenance and adjustment

EAU36114

## Canister

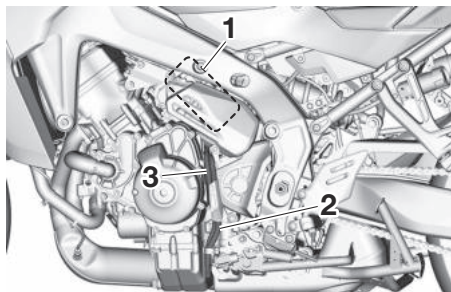

1. Canister
2. Canister breather hose
3. Fuel tank overflow hose

This model is equipped with a canister to prevent the discharging of fuel vapor into the atmosphere. Before operating this vehicle, make sure to check the following:

- Check each hose connection.
- Check each hose and canister for cracks or damage. Replace if damaged.
- Make sure that the canister breather is not blocked, and if necessary, clean it.

## Engine oil

The engine oil level should be checked regularly. In addition, the oil must be changed and the oil filter cartridge replaced at the intervals specified in the periodic maintenance chart.

### Recommended engine oil:

See page 11-1.

### Oil quantity:

Oil change:

2.80 L (2.96 US qt, 2.46 Imp. qt)

With oil filter removal:

3.20 L (3.38 US qt, 2.82 Imp. qt)

EAU1990H

ECA11621

## NOTICE

- **In order to prevent clutch slippage (since the engine oil also lubricates the clutch), do not mix any chemical additives. Do not use oils with a diesel specification of “CD” or oils of a higher quality than specified. In addition, do not use oils labeled “ENERGY CONSERVING II” or higher.**
- **Make sure that no foreign material enters the crankcase.**

## To check the engine oil level

1. Start the engine, warm it up for several minutes, and then turn it off.
2. Wait a few minutes until the oil level settles and with the vehicle on a level surface, hold it upright for an accurate reading.
3. Look at the check window located at the bottom-right side of the crankcase.

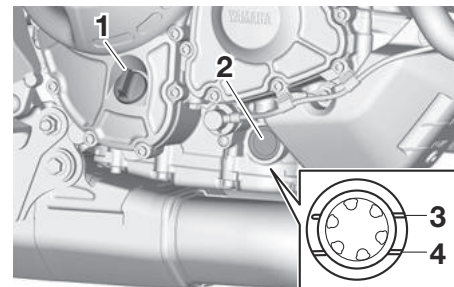

1. Engine oil filler cap
2. Engine oil level check window
3. Maximum level mark
4. Minimum level mark

## TIP

The engine oil should be between the minimum and maximum level marks.

# Periodic maintenance and adjustment

4. If the engine oil is at or below the minimum level mark, remove the oil filler cap and add oil.
5. Check the engine oil filler cap O-ring. Replace if damaged.

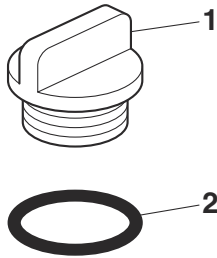

1. Engine oil filler cap
2. O-ring

6. Install the engine oil filler cap.

## To change the engine oil (and filter)

1. Start the engine and allow it to idle for a few minutes to warm up the oil, and then stop the engine.
2. Place an oil pan under the engine to collect the used oil.
3. Remove the engine oil filler cap, and then the engine oil drain bolt and gasket.

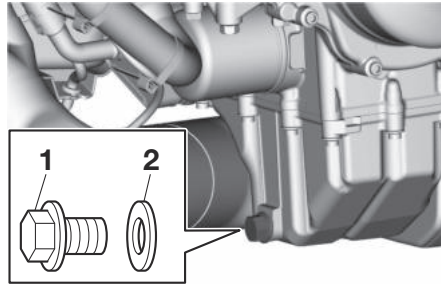

1. Engine oil drain bolt
2. Gasket

## TIP

Skip steps 4–6 if the oil filter cartridge is not being replaced.

4. Remove the oil filter cartridge with an oil filter wrench.

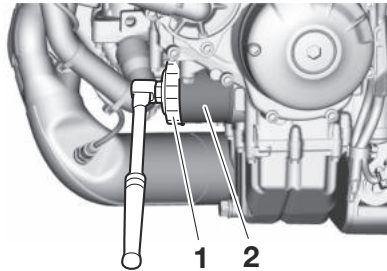

1. Oil filter wrench

2. Oil filter cartridge

## TIP

An oil filter wrench is available at a Yamaha dealer.

5. Apply a thin coat of clean engine oil to the O-ring of the new oil filter cartridge.

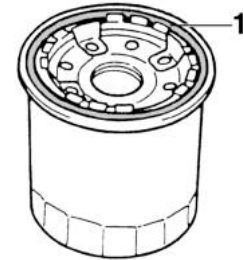

1. O-ring

## TIP

Make sure that the O-ring is properly seated.

6. Install the new oil filter cartridge, and then tighten to the specified torque.

# Periodic maintenance and adjustment

EAU85450

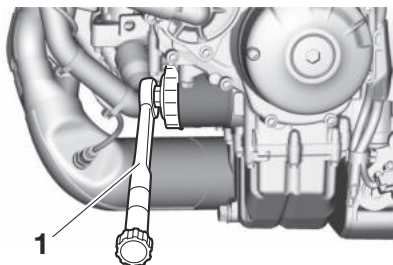

1. Torque wrench

## Tightening torque:

Oil filter cartridge:  
17 N·m (1.7 kgf·m, 13 lb·ft)

7. Install the engine oil drain bolt with a new gasket, and then tighten the bolt to the specified torque.

## Tightening torque:

Engine oil drain bolt:  
43 N·m (4.3 kgf·m, 32 lb·ft)

8. Pour the specified amount of the recommended oil into the crankcase.

**TIP** \_\_\_\_\_

Using a funnel is recommended.

9. After checking the engine oil filler cap O-ring, install the filler cap.

**TIP** \_\_\_\_\_

Wipe off any spilled oil before starting the engine.

10. Start the engine and let it idle while checking for oil leaks.

**TIP** \_\_\_\_\_

If any oil leaks are found which you cannot fix, have the vehicle inspected.

11. Stop the engine, wait a few minutes for the oil level to settle, and then check the oil level one last time. **NOTICE: Do not operate the vehicle until you know that the engine oil level is sufficient.**

[ECA10012]

## Why Yamalube

YAMALUBE oil is a Genuine YAMAHA Part born of the engineers' passion and belief that engine oil is an important liquid engine component. We form teams of specialists in the fields of mechanical engineering, chemistry, electronics and track testing, and have them develop the engine together with the oil it will use. Yamalube oils take full advantage of the base oil's qualities and blend in the ideal balance of additives to make sure the final oil clears our performance standards. Thus, Yamalube mineral, semisynthetic and synthetic oils have their own distinct characters and value. Yamaha's experience gained over many years of research and development into oil since the 1960's helps make Yamalube the best choice for your Yamaha engine.

# YAMALUBE®

## Coolant

The coolant level should be checked regularly. In addition, the coolant must be changed at the intervals specified in the periodic maintenance chart.

EAU84230

### Recommended coolant:

YAMAHA GENUINE COOLANT

### Coolant quantity:

Coolant reservoir (max level mark):  
0.28 L (0.30 US qt, 0.25 Imp.qt)

Radiator (including all routes):  
1.72 L (1.82 US qt, 1.51 Imp.qt)

## TIP

If genuine Yamaha coolant is not available, use an ethylene glycol antifreeze containing corrosion inhibitors for aluminum engines and mix with distilled water at a 1:1 ratio.

EAU20097

## To check the coolant level

Since the coolant level varies with engine temperature, check when the engine is cold.

1. Park the vehicle on a level surface.

2. With the vehicle in an upright position, look at the coolant level in the reservoir.

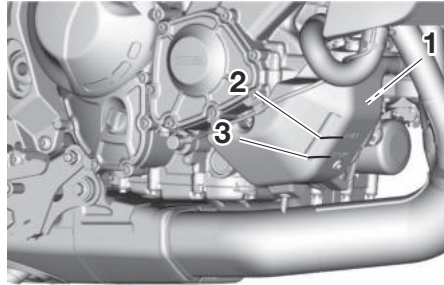

1. Coolant reservoir
2. Maximum level mark
3. Minimum level mark

3. If the coolant is at or below the minimum level mark, remove the coolant reservoir cap. **WARNING! Remove only the coolant reservoir cap. Never attempt to remove the radiator cap when the engine is hot.**<sup>[EWA15162]</sup>

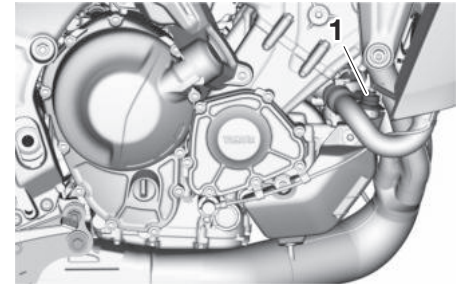

1. Coolant reservoir cap

4. Add coolant to the maximum level mark. **NOTICE: If coolant is not available, use distilled water or soft tap water instead. Do not use hard water or salt water since it is harmful to the engine. If water has been used instead of coolant, replace it with coolant as soon as possible, otherwise the cooling system will not be protected against frost and corrosion. If water has been added to the coolant, have a Yamaha dealer check the anti-freeze content of the coolant as soon as possible, otherwise the effectiveness of the coolant will be reduced.**<sup>[ECA10473]</sup>

# Periodic maintenance and adjustment

---

5. Install the coolant reservoir cap.

## Changing the coolant

EAU33032

The coolant must be changed at the intervals specified in the periodic maintenance and lubrication chart. Have a Yamaha dealer change the coolant.

**WARNING! Never attempt to remove the radiator cap when the engine is hot.**<sup>[EWA10382]</sup>

## Air filter element

EAU36765

The air filter element must be replaced at the intervals specified in the periodic maintenance and lubrication chart. Have a Yamaha dealer replace the air filter element.

## Checking the engine idling speed

EAU44735

Check the engine idling speed and, if necessary, have it corrected by a Yamaha dealer.

<b>Engine idling speed:</b> 1200–1400 r/min
--

# Periodic maintenance and adjustment

EAU21403

## Valve clearance

The valves are an important engine component, and since valve clearance changes with use, they must be checked and adjusted at the intervals specified in the periodic maintenance chart. Unadjusted valves can result in improper air-fuel mixture, engine noise, and eventually engine damage. To prevent this from occurring, have your Yamaha dealer check and adjust the valve clearance at regular intervals.

### TIP

This service must be performed when the engine is cold.

EAU5100

## Tires

Tires are the only contact between the vehicle and the road. Safety in all conditions of riding depends on a relatively small area of road contact. Therefore, it is essential to maintain the tires in good condition at all times and replace them at the appropriate time with the specified tires.

### Tire air pressure

The tire air pressure should be checked and, if necessary, adjusted before each ride.

EWA10504



**Operation of this vehicle with improper tire pressure may cause severe injury or death from loss of control.**

- The tire air pressure must be checked and adjusted on cold tires (i.e., when the temperature of the tires equals the ambient temperature).
- The tire air pressure must be adjusted in accordance with the riding speed and with the total

**weight of rider, passenger, cargo, and accessories approved for this model.**

### Cold tire air pressure:

#### 1 person:

Front:

250 kPa (2.50 kgf/cm<sup>2</sup>, 36 psi)

Rear:

290 kPa (2.90 kgf/cm<sup>2</sup>, 42 psi)

#### 2 persons:

Front:

250 kPa (2.50 kgf/cm<sup>2</sup>, 36 psi)

Rear:

290 kPa (2.90 kgf/cm<sup>2</sup>, 42 psi)

### Maximum load:

Vehicle:

197 kg (434 lb)

The vehicle's maximum load is the combined weight of the rider, passenger, cargo, and any accessories.

EWA10512



**Never overload your vehicle. Operation of an overloaded vehicle could cause an accident.**

# Periodic maintenance and adjustment

## Tire inspection

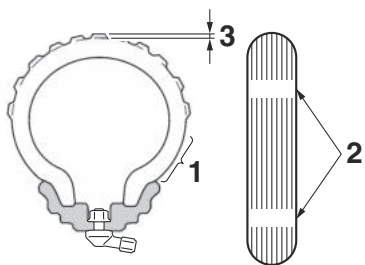

1. Tire sidewall
2. Tire wear indicator
3. Tire tread depth

The tires must be checked before each ride. If a tire tread shows crosswise lines (minimum tread depth), if the tire has a nail or glass fragments in it, or if the sidewall is cracked, have a Yamaha dealer replace the tire immediately.

**Minimum tire tread depth (front and rear):**  
1.0 mm (0.04 in)

EWA10583

### **WARNING**

- It is dangerous to ride with a worn-out tire. When a tire tread

begins to show crosswise lines, have a Yamaha dealer replace the tire immediately.

- The replacement of all wheel and brake-related parts, including the tires, should be left to a Yamaha dealer, who has the necessary professional knowledge and experience to do so.
- Ride at moderate speeds after changing a tire since the tire surface must first be “broken in” for it to develop its optimal characteristics.

## Tire information

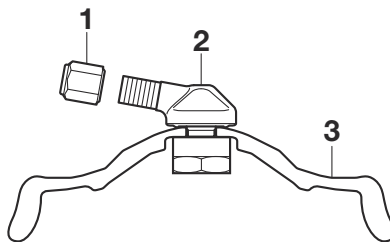

1. Tire air valve cap with seal
2. Clamp-in valve

3. Wheel rim

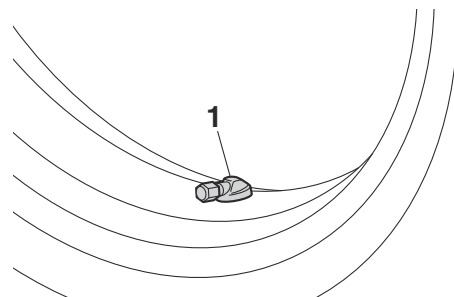

1. Tire air valve

This model is equipped with tubeless tires and tire air valves.

Tires age, even if they have not been used or have only been used occasionally. Cracking of the tread and sidewall rubber, sometimes accompanied by carcass deformation, is an evidence of ageing. Old and aged tires shall be checked by tire specialists to ascertain their suitability for further use.

EWA22890

### **WARNING**

- The front and rear tires should be of the same make and design, otherwise the handling characteristics of the vehicle

may be different, which could lead to an accident.

- **Always make sure that the valve caps are securely installed to prevent air pressure leakage.**
- **Use only the tire valves and valve cores listed below to avoid tire deflation during a ride.**
- **The tire air valve original position is with the valve cap pointing to the right side of the vehicle, perpendicular (90 degree right angle) to the axis (center line) of the wheel. If the tire air valve becomes misaligned, do not twist it back to its original position by yourself. Otherwise, leakage may occur. Have a Yamaha dealer inspect the valve.**

---

After extensive tests, only the tires listed below have been approved for this model by Yamaha.

## **Front tire:**

Size:

120/70ZR17M/C (58W)

Manufacturer/model:

BRIDGESTONE/BATTLAX SPORT  
TOURING T32F

Tire air valve:

PVR255

Valve core:

#9200 (original)

## **Rear tire:**

Size:

180/55ZR17M/C (73W)

Manufacturer/model:

BRIDGESTONE/BATTLAX SPORT  
TOURING T32R

Tire air valve:

PVR255

Valve core:

#9200 (original)

## **Cast wheels**

To maximize the performance, durability, and safe operation of your vehicle, note the following points regarding the specified wheels.

- The wheel rims should be checked for cracks, bends, warpage or other damage before each ride. If any damage is found, have a Yamaha dealer replace the wheel. Do not attempt even the smallest repair to the wheel. A deformed or cracked wheel must be replaced.
- The wheel should be balanced whenever either the tire or wheel has been changed or replaced. An unbalanced wheel can result in poor performance, adverse handling characteristics, and a shortened tire life.

# Periodic maintenance and adjustment

## Checking the brake lever free play

EAU37914

result in loss of control and an accident.

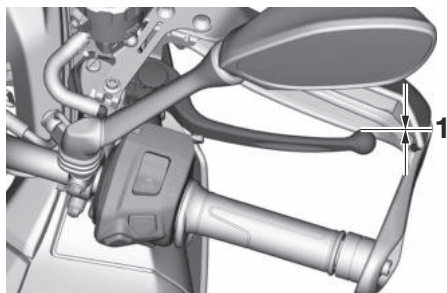

1. No brake lever free play

There should be no free play at the brake lever end. If there is free play, have a Yamaha dealer inspect the brake system.

EWA14212

### **WARNING**

**A soft or spongy feeling in the brake lever can indicate the presence of air in the hydraulic system. If there is air in the hydraulic system, have a Yamaha dealer bleed the system before operating the vehicle. Air in the hydraulic system will diminish the braking performance, which may re-**

## Brake light switches

EAU36505

The brake light should come on just before braking takes effect. The brake light is activated by switches connected to the brake lever and brake pedal. Since the brake light switches are components of the anti-lock brake system, they should only be serviced by a Yamaha dealer.

## Checking the front and rear brake pads

EAU22393

The front and rear brake pads must be checked for wear at the intervals specified in the periodic maintenance and lubrication chart.

### Front brake pads

EAU36892

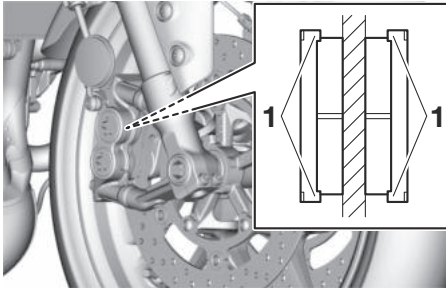

1. Brake pad wear indicator

Each front brake pad is provided with wear indicators, which allows you to check the brake pad wear without having to disassemble the brake. To check the brake pad wear, check the position of the wear indicators while applying the brake. If a brake pad has worn to the point that a wear indicator almost

touches the brake disc, have a Yamaha dealer replace the brake pads as a set.

### Rear brake pads

EAU46292

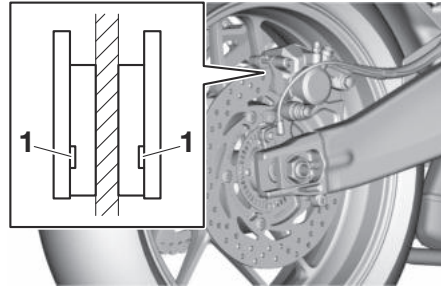

1. Brake pad wear indicator groove

Each rear brake pad is provided with wear indicator grooves, which allow you to check the brake pad wear without having to disassemble the brake. To check the brake pad wear, check the wear indicator grooves. If a brake pad has worn to the point that a wear indicator groove almost appears, have a Yamaha dealer replace the brake pads as a set.

## Checking the brake fluid level

EAU66670

Before riding, check that the brake fluid is above the minimum level mark. Check the brake fluid level with the top of the reservoir level. Replenish the brake fluid if necessary.

### Front brake

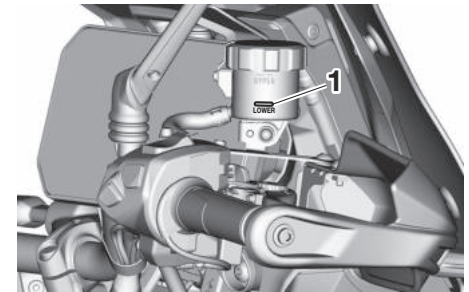

1. Minimum level mark

# Periodic maintenance and adjustment

## Rear brake

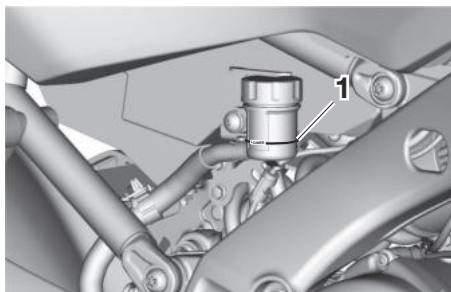

1. Minimum level mark

**Specified brake fluid:**  
YAMAHA GENUINE BRAKE FLUID  
(DOT 4)

EWA16011

### **WARNING**

Improper maintenance can result in loss of braking ability. Observe these precautions:

- Insufficient brake fluid may allow air to enter the brake system, reducing braking performance.
- Clean the filler cap before removing. Use only DOT 4 brake fluid from a sealed container.

- Use only the specified brake fluid; otherwise, the rubber seals may deteriorate, causing leakage.
- Refill with the same type of brake fluid. Adding a brake fluid other than DOT 4 may result in a harmful chemical reaction.
- Be careful that water or dust does not enter the brake fluid reservoir when refilling. Water will significantly lower the boiling point of the fluid and may result in vapor lock, and dirt may clog the ABS hydraulic unit valves.

fluid level goes down suddenly, have a Yamaha dealer check the cause before further riding.

### **NOTICE**

**Brake fluid may damage painted surfaces or plastic parts. Always clean up spilled fluid immediately.**

As the brake pads wear, it is normal for the brake fluid level to gradually go down. A low brake fluid level may indicate worn brake pads and/or brake system leakage; therefore, be sure to check the brake pads for wear and the brake system for leakage. If the brake

ECA17641

# Periodic maintenance and adjustment

## Changing the brake fluid

EAU22734

Have a Yamaha dealer change the brake fluid every 2 years. In addition, have the seals of the master cylinders and brake calipers, as well as the brake hoses replaced at the intervals listed below or sooner if they are damaged or leaking.

- Brake seals: every 2 years
- Brake hoses: every 4 years

## Drive chain slack

EAU22762

The drive chain slack should be checked before each ride and adjusted if necessary.

### To check the drive chain slack

EAU92611

1. Place the motorcycle on the centerstand.
2. Shift the transmission into the neutral position.
3. Find the center point of the chain (position B) by measuring (approx. 53 mm (2.09 in)) forward from the edge of the drive chain guard as shown.

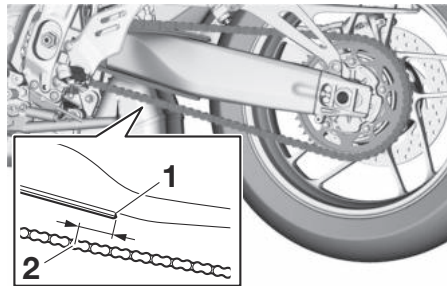

1. Edge of the drive chain guard
2. Position B

4. Push down on the center of the drive chain and measure the distance A from the drive chain guard to the middle of the chain link being pressed down at position B.

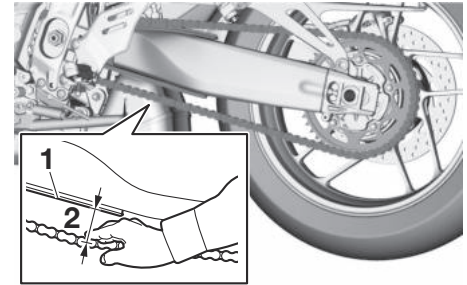

1. Drive chain guard
2. Distance A

### Distance A:

45.0–50.0 mm (1.77–1.97 in)

5. If distance A is incorrect, adjust it as follows. **NOTICE: Improper drive chain slack will overload the engine as well as other vital parts of the motorcycle and can lead to chain slippage or breakage. If distance A is more than 55.0 mm (2.17 in), the chain can**

# Periodic maintenance and adjustment

damage the frame, swingarm, and other parts. To prevent this from occurring, keep the drive chain slack within the specified limits.<sup>[ECA23070]</sup>

EAU92600

## To adjust the drive chain slack

Consult a Yamaha dealer before adjusting the drive chain slack.

1. Take the motorcycle off the centerstand, and then put the sidestand down.
2. Loosen the axle nut and the locknut on each side of the swingarm.

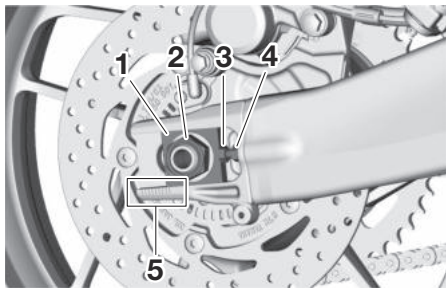

1. Drive chain puller
2. Axle nut
3. Drive chain slack adjusting bolt
4. Locknut

5. Alignment marks
3. Place the motorcycle on the centerstand.
4. To tighten the drive chain, turn the drive chain slack adjusting bolt on each side of the swingarm in direction (a). To loosen the drive chain, turn the adjusting bolt on each side of the swingarm in direction (b), and then push the rear wheel forward.

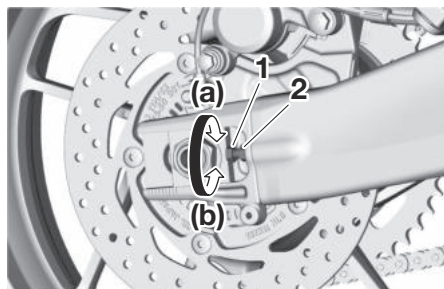

1. Drive chain slack adjusting bolt
2. Locknut

## TIP

Using the alignment marks on each side of the swingarm, make sure that

both drive chain pullers are in the same position for proper wheel alignment.

5. Take the motorcycle off the centerstand, and then put the sidestand down.
6. Tighten the axle nut, then the locknuts to their specified torques.

## Tightening torques:

Axle nut:

105 N·m (10.5 kgf·m, 77 lb·ft)

Locknut:

16 N·m (1.6 kgf·m, 12 lb·ft)

7. Make sure that the drive chain pullers are in the same position, the drive chain slack is correct, and the drive chain moves smoothly.

## Cleaning and lubricating the drive chain

EAU23027

The drive chain must be cleaned and lubricated at the intervals specified in the periodic maintenance and lubrication chart, otherwise it will quickly wear out, especially when riding in dusty or wet areas. Service the drive chain as follows.

ECA10584

### **NOTICE**

**The drive chain must be lubricated after washing the motorcycle, riding in the rain or riding in wet areas.**

1. Clean the drive chain with a drive chain cleaner and a small soft brush. **NOTICE: To prevent damaging the O-rings, do not clean the drive chain with steam cleaners, high-pressure washers or inappropriate solvents.**

[ECA11122]

2. Wipe the drive chain dry.
3. Thoroughly lubricate the drive chain with a special O-ring chain lubricant. **NOTICE: Do not use engine oil or any other lubricants**

**for the drive chain, as they may contain substances that could damage the O-rings.**[ECA11112]

## Checking and lubricating the cables

EAU23098

The operation of all control cables and the condition of the cables should be checked before each ride, and the cables and cable ends should be lubricated if necessary. If a cable is damaged or does not move smoothly, have a Yamaha dealer check or replace it. **WARNING! Damage to the outer housing of cables may result in internal rusting and cause interference with cable movement. Replace damaged cables as soon as possible to prevent unsafe conditions.**[EWA10712]

### **Recommended lubricant:**

Yamaha cable lubricant or other suitable cable lubricant

# Periodic maintenance and adjustment

## Checking and lubricating the throttle grip

EAU82490

The operation of the throttle grip should be checked before each ride. In addition, the throttle grip housing should be lubricated by a Yamaha dealer at the intervals specified in the periodic maintenance chart.

## Checking and lubricating the brake lever

EAU23155

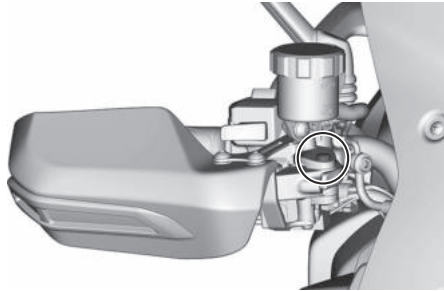

The operation of the brake lever should be checked before each ride, and the lever pivot should be lubricated if necessary.

**Recommended lubricant:**  
Silicone grease

## Checking and lubricating the brake pedal

EAU23185

The operation of the brake pedal should be checked before each ride, and the pedal pivot should be lubricated if necessary.

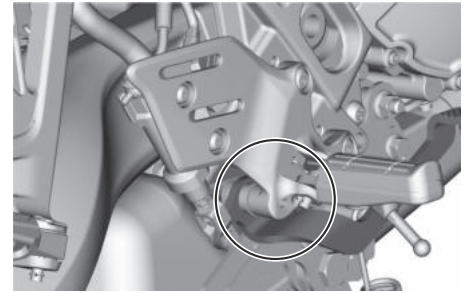

**Recommended lubricant:**  
Lithium-soap-based grease

# Periodic maintenance and adjustment

## Checking and lubricating the centerstand and sidestand

EAU88860

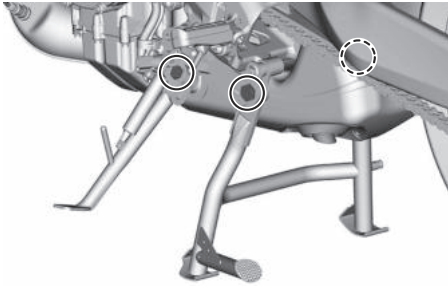

The operation of the centerstand and sidestand should be checked before each ride, and the pivots and metal-to-metal contact surfaces should be lubricated if necessary.

EWA10742



**If the centerstand or sidestand does not move up and down smoothly, have a Yamaha dealer check or repair it. Otherwise, the centerstand or sidestand could contact the ground and distract the operator, resulting in a possible loss of control.**

### Recommended lubricants:

Centerstand:

Lithium-soap-based grease

Sidestand:

Molybdenum disulfide grease

## Lubricating the swingarm pivots

EAUM1653

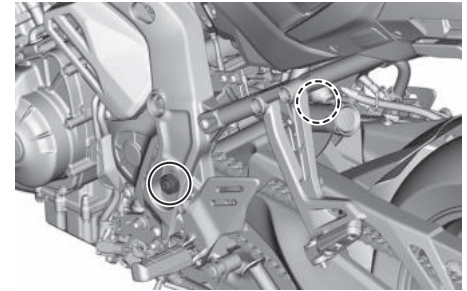

The swingarm pivots must be lubricated by a Yamaha dealer at the intervals specified in the periodic maintenance and lubrication chart.

### Recommended lubricant:

Lithium-soap-based grease

# Periodic maintenance and adjustment

EAU23273

## Checking the front fork

The condition and operation of the front fork must be checked as follows at the intervals specified in the periodic maintenance and lubrication chart.

### To check the condition

Check the inner tubes for scratches, damage and excessive oil leakage.

### To check the operation

1. Place the vehicle on a level surface and hold it in an upright position. **WARNING! To avoid injury, securely support the vehicle so there is no danger of it falling over.**<sup>[EWA10752]</sup>
2. While applying the front brake, push down hard on the handlebars several times to check if the front fork compresses and rebounds smoothly.

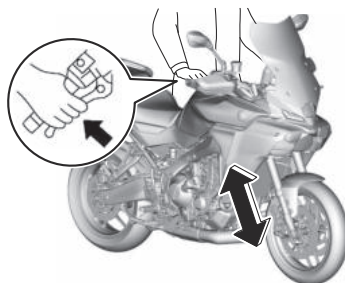

ECA10591

### NOTICE

**If any damage is found or the front fork does not operate smoothly, have a Yamaha dealer check or repair it.**

EAU45512

## Checking the steering

Worn or loose steering bearings may cause danger. Therefore, the operation of the steering must be checked as follows at the intervals specified in the periodic maintenance and lubrication chart.

1. Place the vehicle on the center-stand. **WARNING! To avoid injury, securely support the vehicle so there is no danger of it falling over.**<sup>[EWA10752]</sup>
2. Hold the lower ends of the front fork legs and try to move them forward and backward. If any free play can be felt, have a Yamaha dealer check or repair the steering.

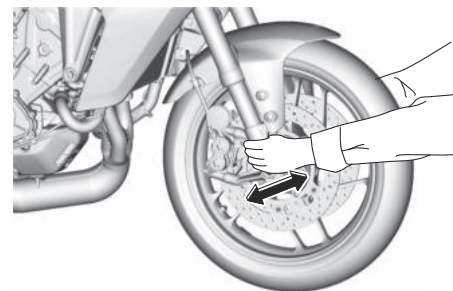

## Checking the wheel bearings

EAU23292

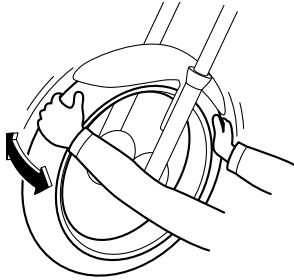

The front and rear wheel bearings must be checked at the intervals specified in the periodic maintenance and lubrication chart. If there is play in the wheel hub or if the wheel does not turn smoothly, have a Yamaha dealer check the wheel bearings.

## Battery

EAU93320

ECA22960

### NOTICE

Use only the specified genuine YAMAHA battery. Using a different battery may cause the IMU to fail and the engine to stall.

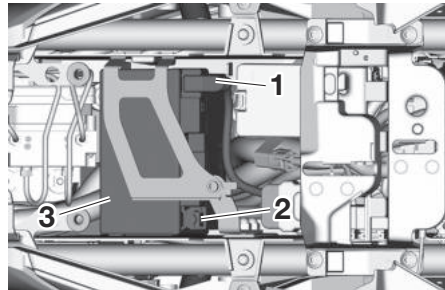

1. Positive battery lead (red)
2. Negative battery lead (black)
3. Battery

The battery is located under the rider seat. (See page 6-44.)

This model is equipped with a VRLA (Valve Regulated Lead Acid) battery. There is no need to check the electrolyte or to add distilled water. However, the battery lead connections need to

be checked and, if necessary, tightened.

EWA10761

### WARNING

- Electrolyte is poisonous and dangerous since it contains sulfuric acid, which causes severe burns. Avoid any contact with skin, eyes or clothing and always shield your eyes when working near batteries. In case of contact, administer the following FIRST AID.
  - **EXTERNAL:** Flush with plenty of water.
  - **INTERNAL:** Drink large quantities of water or milk and immediately call a physician.
  - **EYES:** Flush with water for 15 minutes and seek prompt medical attention.
- Batteries produce explosive hydrogen gas. Therefore, keep sparks, flames, cigarettes, etc., away from the battery and provide sufficient ventilation when charging it in an enclosed space.

# Periodic maintenance and adjustment

- **KEEP THIS AND ALL BATTERIES OUT OF THE REACH OF CHILDREN.**

## To charge the battery

Have a Yamaha dealer charge the battery as soon as possible if it seems to have discharged. Keep in mind that the battery tends to discharge more quickly if the vehicle is equipped with optional electrical accessories.

ECA16522

### NOTICE

To charge a VRLA (Valve Regulated Lead Acid) battery, a special (constant-voltage) battery charger is required. Using a conventional battery charger will damage the battery.

## To store the battery

1. If the vehicle will not be used for more than one month, remove the battery, fully charge it, and then place it in a cool, dry place. **NOTICE: When removing the battery, be sure to turn the main switch off, then disconnect the**

**negative lead before disconnecting the positive lead.**<sup>[ECA16304]</sup>

2. If the battery will be stored for more than two months, check it at least once a month and fully charge it if necessary.
3. Fully charge the battery before installation. **NOTICE: When installing the battery, be sure to turn the main switch off, then connect the positive lead before connecting the negative lead.**
4. After installation, make sure that the battery leads are properly connected to the battery terminals.

[ECA16842]

ECA16531

### NOTICE

**Always keep the battery charged. Storing a discharged battery can cause permanent battery damage.**

## Replacing the fuses

EUAU4691

The fuse box and sub fuse are located under the rider seat. (See page 6-44.)

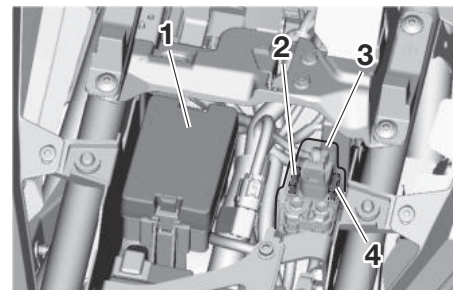

1. Fuse box
2. Sub fuse
3. Starter relay case cover
4. Spare sub fuse

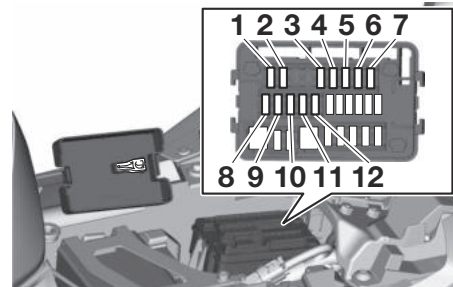

1. Brake light fuse

# Periodic maintenance and adjustment

2. Cruise control fuse
3. Signaling system fuse
4. Ignition fuse
5. Ignition fuse 2
6. Headlight fuse
7. ABS control unit fuse
8. Terminal fuse 1
9. Ignition fuse 3
10. Accessory fuse
11. Radiator fan motor fuse
12. Heater fuse

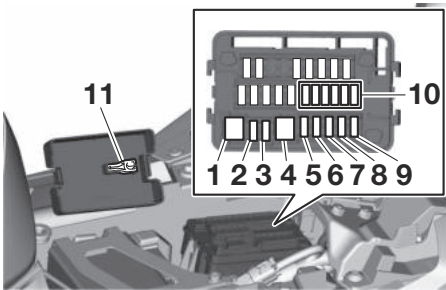

1. Y-AMT motor control fuse
2. ABS solenoid fuse
3. ABS motor fuse
4. Main fuse
5. Backup fuse
6. SCU fuse
7. Fuel injection system fuse
8. Electronic throttle valve fuse

9. Backup fuse 2
10. Spare fuse
11. Fuse puller

If a fuse is blown, replace it as follows.

## TIP

Use a fuse puller to remove the fuse.

1. Turn the main switch off and turn off the electrical circuit in question.
2. Remove the fuse box cover by pressing inwards at the two points indicated on the cover and pulling upwards.

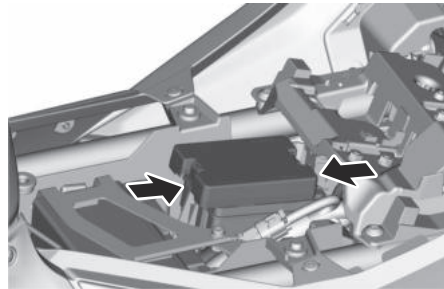

3. Remove the blown fuse using the fuse puller.

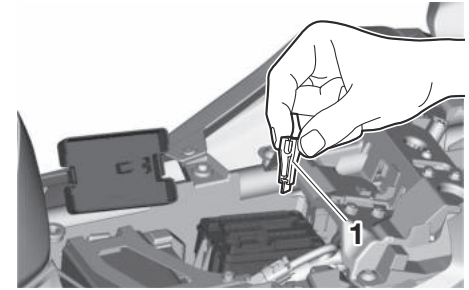

1. Fuse puller

4. Install a new fuse of the specified amperage. **WARNING! Do not use a fuse of a higher amperage rating than recommended to avoid causing extensive damage to the electrical system and possibly a fire.**<sup>[EWA15132]</sup>

# Periodic maintenance and adjustment

## Specified fuses:

- Main fuse:
  - 60.0 A
- Sub fuse:
  - 30.0 A
- Terminal fuse 1:
  - 5.0 A
- Heater fuse:
  - 7.5 A
- Headlight fuse:
  - 10.0 A
- Brake light fuse:
  - 2.0 A
- Signaling system fuse:
  - 7.5 A
- Ignition fuse:
  - 15.0 A
- Ignition fuse 2:
  - 5.0 A
- Ignition fuse 3:
  - 5.0 A
- Radiator fan motor fuse:
  - 15.0 A
- ABS motor fuse:
  - 30.0 A
- Fuel injection system fuse:
  - 7.5 A
- SCU fuse:
  - 7.5 A
- ABS solenoid fuse:
  - 15.0 A
- ABS control unit fuse:
  - 7.5 A

- Y-AMT motor control fuse:
  - 50.0 A
- Cruise control fuse:
  - 2.0 A
- Backup fuse:
  - 10.0 A
- Backup fuse 2:
  - 15.0 A
- Electronic throttle valve fuse:
  - 7.5 A
- Accessory fuse:
  - 5.0 A

5. Insert the fuse puller, and then install the fuse box cover.
6. Turn the main switch on and turn on the electrical circuit in question to check if the device operates.
7. If the fuse immediately blows again, have a Yamaha dealer check the electrical system.

ECA27210

### **NOTICE**

**Do not drive while the fuse box cover is removed.**

EAU80380

## Vehicle lights

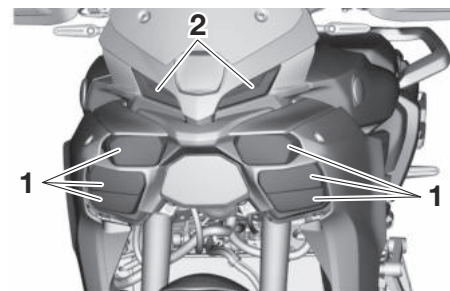

1. Headlight
2. Auxiliary light

Except for the license plate light bulb, this model's lights are all LED. If an LED light does not come on, check the fuses and then have a Yamaha dealer check the vehicle. If the license plate light does not come on, check and replace the bulb. (See page 9-30.)

ECA16581

### **NOTICE**

**Do not affix any type of tinted film or stickers to the headlight lens.**

## Replacing the license plate light bulb

EAU92581

1. Remove the bolts securing the license plate light unit.

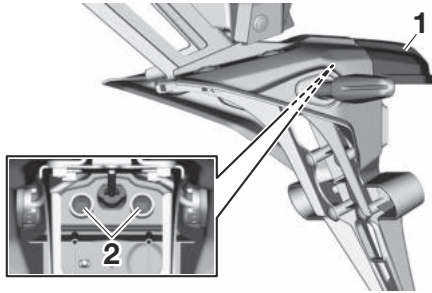

1. License plate light unit
2. Bolt

2. Pull the license plate light unit separate from the rear fender. (Reinstall the collars if they fall out.)

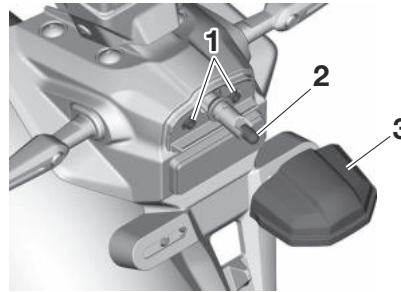

1. Collar
2. License plate light bulb
3. License plate light unit

3. Remove the license plate light bulb socket (together with the bulb) by turning it counterclockwise, and then pulling it out.
4. Remove the burnt-out bulb by pulling it out.
5. Insert a new bulb into the socket.
6. Install the socket (together with the bulb) by pushing it in, and then turning it clockwise until it stops.
7. Install the license plate unit onto the rear fender.
8. Install the bolts and tighten to the specified torque.

### Tightening torque:

License plate light unit bolt:  
4.0 N·m (0.4 kgf·m, 3.0 lb·ft)

# Periodic maintenance and adjustment

## Troubleshooting

Although Yamaha motorcycles receive a thorough inspection before shipment from the factory, trouble may occur during operation. Any problem in the fuel, compression, or ignition systems, for example, can cause poor starting and loss of power.

The following troubleshooting charts represent quick and easy procedures for checking these vital systems yourself. However, should your motorcycle require any repair, take it to a Yamaha dealer, whose skilled technicians have the necessary tools, experience, and know-how to service the motorcycle properly.

Use only genuine Yamaha replacement parts. Imitation parts may look like Yamaha parts, but they are often inferior, have a shorter service life and can lead to expensive repair bills.

### WARNING

**When checking the fuel system, do not smoke, and make sure there are no open flames or sparks in the area, including pilot lights from water**

EAU25873

**heaters or furnaces. Gasoline or gasoline vapors can ignite or explode, causing severe injury or property damage.**

EAU76552

### Smart key system troubleshooting

Please check the following items when the smart key system does not work.

- Is the smart key turned on? (See page 4-35.)
- Is the smart key battery discharged? (See page 4-35.)
- Is the smart key battery installed correctly? (See page 4-35.)
- Is the smart key being used in a location with strong radio waves or other electromagnetic noise? (See page 4-31.)
- Are you using the smart key that is registered to the vehicle?
- Is the vehicle battery discharged? When the vehicle battery is discharged, the smart key system will not operate. Please have the vehicle battery charged or replaced. (See page 9-26.)

If the smart key system does not work after checking the above items, have a

Yamaha dealer check the smart key system.

### TIP

See Emergency mode on page 9-35 for information on starting the engine without the smart key.

EAU2841

### Shifting gears by hand

If the Yamaha-Automated Manual Transmission (Y-AMT) system experiences a malfunction or if the battery is drained, it is feasible to manually shift the transmission to neutral when the vehicle power is off by using the following method.

EWA22731

### WARNING

- **Do not attempt this procedure when the engine is hot. Doing so can result in severe burns.**
- **Do not turn on the vehicle power unless the cover is installed over the shifter rod. Unintentional shift actuation can occur and pinch body parts and/or clothing, causing serious injury.**

# Periodic maintenance and adjustment

1. Remove the cover by removing the bolts as shown.

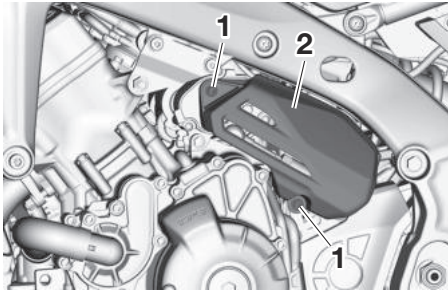

1. Bolt
2. Cover

2. Place your hand(s) under the shift rod as shown and push hard in direction (a) until a solid click is felt.

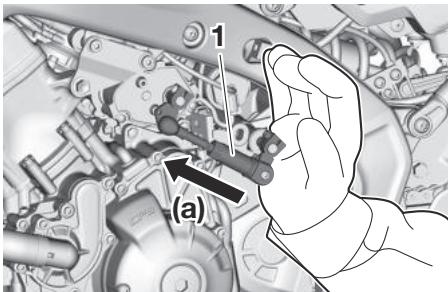

1. Shift rod

3. Grip the handlebars as shown and push the vehicle slightly forward and backward until a click is heard indicating a gearshift has occurred.

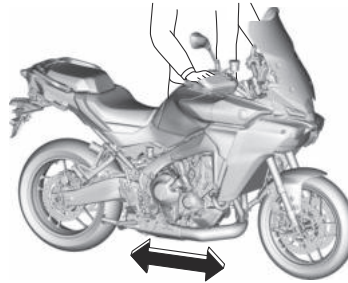

4. If more downshifts are required, repeat steps 2-3 until the vehicle rolls freely in neutral.
5. Install the cover.

# Periodic maintenance and adjustment

EAU86350

## Troubleshooting chart

### 1. Fuel

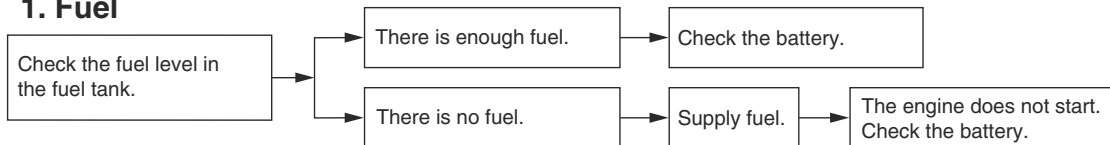

### 2. Battery

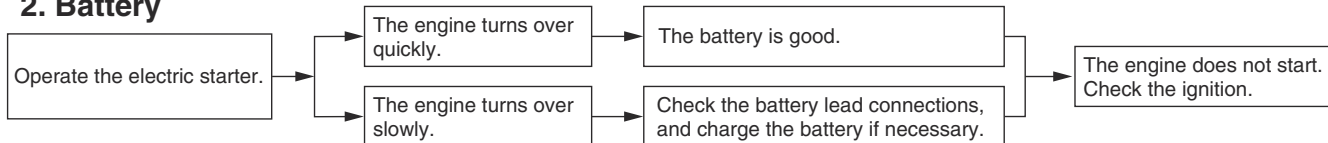

### 3. Ignition

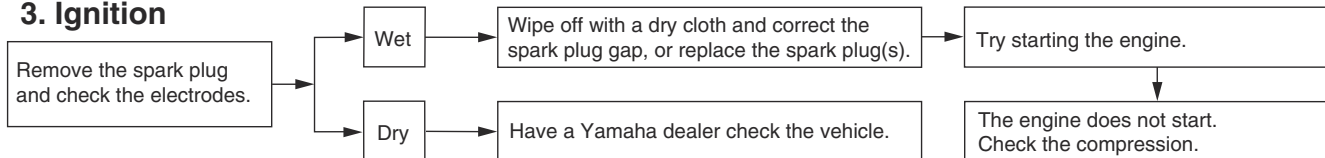

### 4. Compression

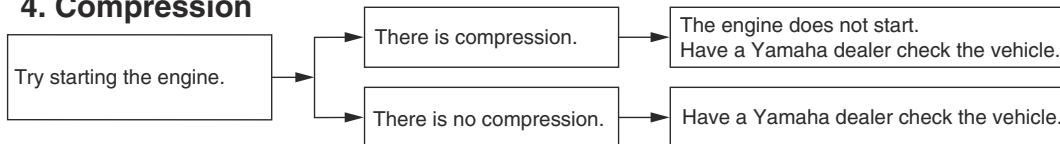

## Engine overheating

### WARNING

- Do not remove the radiator cap when the engine and radiator are hot. Scalding hot fluid and steam may be blown out under pressure, which could cause serious injury. Be sure to wait until the engine has cooled.
- Place a thick rag, like a towel, over the radiator cap, and then slowly rotate the cap counterclockwise to the detent to allow any residual pressure to escape. When the hissing sound has stopped, press down on the cap while turning it counterclockwise, and then remove the cap.

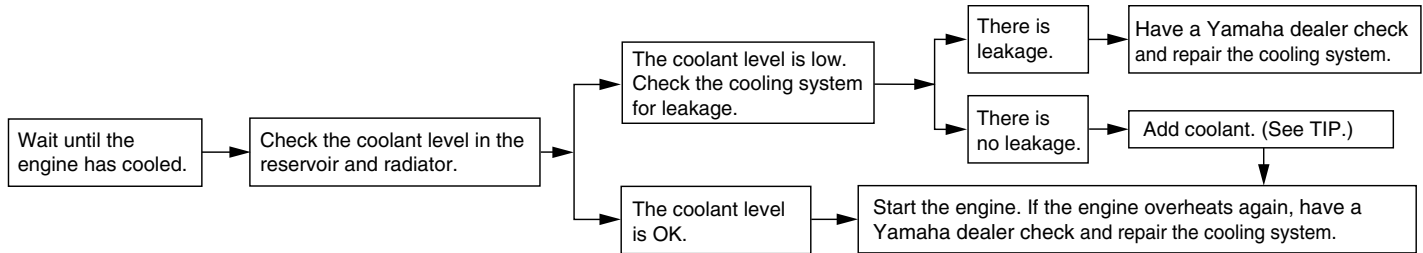

### TIP

If coolant is not available, tap water can be temporarily used instead, provided that it is changed to the recommended coolant as soon as possible.

# Periodic maintenance and adjustment

EAUJ2620

## Emergency mode

When the smart key is lost or damaged, or its battery has discharged, the vehicle can still be turned on and the engine started. You will need the smart key system identification number.

### To operate the vehicle in emergency mode

1. Stop the vehicle in a safe place and confirm the main switch is set to either “LOCK” or “OFF”.
2. Push the main switch knob for 5 seconds until the smart key system indicator light flashes once, then release it. Repeat two more times. The smart key system indicator light will come on for three seconds to indicate the transition to emergency mode.



1. Smart key system indicator light “”

3. After the smart key system indicator light goes off, input the identification number as follows.

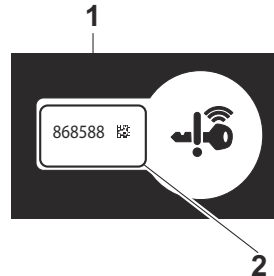

1. Identification number card
2. Identification number

4. Inputting the identification number is done by counting the number of

flashes of the smart key system indicator light.

For example, if the identification number is 123456:

Push and hold the knob.



The smart key system indicator light will start to flash.



Release the knob after the smart key system indicator light flashes once.



The first digit of the identification number has been set as “1”.



Push and hold the knob again.



Release the knob after the smart key system indicator light flashes twice.



The second digit has been set as “2”.



Repeat the above procedure until all digits of the identification number have been set. The smart key system indicator light will flash for 10 seconds if the correct identification number was entered.

## TIP

---

When one of the following situations applies, emergency mode will be terminated and the smart key system indicator light will flash quickly for 3 seconds. In this case, start over again from step 2.

- When there are no knob operations for 10 seconds during the identification number input process.
- When the smart key system indicator light is allowed to flash nine or more times.

- The identification number is not entered correctly.

5. While the smart key system indicator light is on, push the knob once more to complete emergency mode access. The smart key indicator light will go off and then come back on for approximately 4 seconds.
6. While the smart key system indicator light is on, turn the main switch to “ON”. The vehicle can now be operated normally.

# Motorcycle care and storage

---

## Matte color caution

EAU07834

EAU0960

### **NOTICE**

Some models are equipped with matte colored finished parts. Be sure to consult a Yamaha dealer for advice on what products to use before cleaning the vehicle. Using a brush, harsh chemical products or cleaning compounds when cleaning these parts will scratch or damage their surface. Wax also should not be applied to any matte colored finished parts.

ECA15193

## Care

Frequent, thorough cleaning of the vehicle will not only enhance its appearance but also will improve its general performance and extend the useful life of many components. Washing, cleaning, and polishing will also give you a chance to inspect the condition of the vehicle more frequently. Be sure to wash the vehicle after riding in the rain or near the sea, because salt is corrosive to metals.

### **TIP**

- Genuine Yamaha care and maintenance products are sold under the YAMALUBE brand in many markets worldwide.
- See your Yamaha dealer for additional cleaning tips.

ECA26280

### **NOTICE**

Improper cleaning can cause cosmetic and mechanical damage. Do not use:

- high-pressure washers or steam-jet cleaners. Excessive water pressure may cause wa-

ter seepage and deterioration of wheel bearings, brakes, transmission seals and electrical devices. Avoid high-pressure detergent applications such as those available in coin-operated car washers.

- harsh chemicals, including strong acidic wheel cleaners, especially on spoke or magnesium wheels.
- harsh chemicals, abrasive cleaning compounds, or wax on matte-finished parts. Brushes can scratch and damage the matte-finish, use soft sponge or towel only.
- towels, sponges, or brushes contaminated with abrasive cleaning products or strong chemicals such as, solvents, gasoline, rust removers, brake fluid, or antifreeze, etc.

## Before washing

1. Park the vehicle out of direct sunlight and allow it to cool. This will help avoid water spots.

2. Make sure all caps, covers, electrical couplers and connectors are tightly installed.
3. Cover the muffler end with a plastic bag and a strong rubber band.
4. Pre-soak stubborn stains like insects or bird droppings with a wet towel for a few minutes.
5. Remove road grime and oil stains with a quality degreasing agent and a plastic-bristle brush or sponge. **NOTICE: Do not use degreasing agent on areas requiring lubrication such as seals, gaskets, and wheel axles. Follow product instructions.**<sup>[ECA26290]</sup>

## Washing

1. Rinse off any degreaser and spray down the vehicle with a garden hose. Use only enough pressure to do the job. Avoid spraying water directly into the muffler, instrument panel, air inlet, or other inner areas such as underseat storage compartments.
2. Wash the vehicle with a quality automotive-type detergent mixed with cool water and a soft, clean

- towel or sponge. Use an old toothbrush or plastic-bristle brush for hard-to-reach places. **NOTICE: Use cold water if the vehicle has been exposed to salt. Warm water will increase salt's corrosive properties.**<sup>[ECA26301]</sup>
3. For windscreen-equipped vehicles: Clean the windscreen with a soft towel or sponge dampened with water and a pH neutral detergent. If necessary, use a high-quality windscreen cleaner or polish for motorcycles. **NOTICE: Never use any strong chemicals to clean the windscreen. Additionally, some cleaning compounds for plastic may scratch the windscreen, so be sure to test all cleaning products before general application.**<sup>[ECA27860]</sup>
  4. Rinse off thoroughly with clean water. Be sure to remove all detergent residues, as they can be harmful to plastic parts.

## After washing

1. Dry the vehicle with a chamois or absorbent towel, preferably micro-fiber terrycloth.
2. For drive chain-equipped models: Dry and then lubricate the drive chain to prevent rust.
3. Use a chrome polish to shine chrome, aluminum, and stainless steel parts. Often the thermally induced discoloring of stainless steel exhaust systems can be removed through polishing.
4. Apply a corrosion protection spray on all metal parts including chrome or nickel-plated surfaces. **WARNING! Do not apply silicone or oil spray to seats, hand grips, rubber foot pegs or tire treads. Otherwise these parts will become slippery, which could cause loss of control. Thoroughly clean the surfaces of these parts before operating the vehicle.**<sup>[EWA20651]</sup>
5. Treat rubber, vinyl, and unpainted plastic parts with a suitable care product.

# Motorcycle care and storage

---

6. Touch up minor paint damage caused by stones, etc.
7. Wax all painted surfaces using a non-abrasive wax or use a detail spray for motorcycles.
8. When finished cleaning, start the engine and let it idle for several minutes to help dry any remaining moisture.
9. If the headlight lens has fogged up, start the engine and turn on the headlight to help remove the moisture.
10. Let the vehicle dry completely before storing or covering it.

ECA26320

## NOTICE

---

- Do not apply wax to rubber or unpainted plastic parts.
- Do not use abrasive polishing compounds as they will wear away the paint.
- Apply sprays and wax sparingly. Wipe off excess afterwards.

EWA20660

## WARNING

---

Contaminants left on the brakes or tires can cause loss of control.

- **Make sure there is no lubricant or wax on the brakes or tires.**
  - **If necessary, wash the tires with warm water and a mild detergent.**
  - **If necessary, clean the brake discs and pads with brake cleaner or acetone.**
  - **Before riding at higher speeds, test the vehicle's braking performance and cornering behavior.**
- 

EAU83472

## Storage

Always store the vehicle in a cool, dry place. If necessary, protect it against dust with a porous cover. Be sure the engine and the exhaust system are cool before covering the vehicle. If the vehicle often sits for weeks at a time between uses, the use of a quality fuel stabilizer is recommended after each fill-up.

ECA21170

## NOTICE

---

- Storing the vehicle in a poorly ventilated room or covering it with a tarp, while it is still wet, will allow water and humidity to seep in and cause rust.
  - To prevent corrosion, avoid damp cellars, stables (because of the presence of ammonia) and areas where strong chemicals are stored.
- 

## Long term storage

Before storing the vehicle long term (60 days or more):

1. Make all necessary repairs and perform any outstanding maintenance.
2. Follow all instructions in the Care section of this chapter.
3. Fill up the fuel tank, adding fuel stabilizer according to product instructions. Run the engine for 5 minutes to distribute treated fuel through the fuel system.
4. For vehicles equipped with a fuel cock: Turn the fuel cock lever to the off position.
5. For vehicles with a carburetor: To prevent fuel deposits from building up, drain the fuel in the carburetor float chamber into a clean container. Retighten the drain bolt and pour the fuel back into the fuel tank.
6. Use a quality engine fogging oil according to product instructions to protect internal engine components from corrosion. If engine fogging oil is not available, perform the following steps for each cylinder:
  - a. Remove the spark plug cap and spark plug.
  - b. Pour a teaspoonful of engine oil into the spark plug bore.
  - c. Install the spark plug cap onto the spark plug, and then place the spark plug on the cylinder head so that the electrodes are grounded. (This will limit sparking during the next step.)
  - d. Turn the engine over several times with the starter. (This will coat the cylinder wall with oil.)  
**WARNING! To prevent damage or injury from sparking, make sure to ground the spark plug electrodes while turning the engine over.**  
[EWA10952]
  - e. Remove the spark plug cap from the spark plug, and then install the spark plug and the spark plug cap.
7. Lubricate all control cables, pivots, levers and pedals, as well as the sidestand and centerstand (if equipped).
8. Check and correct the tire air pressure, and then lift the vehicle so that all wheels are off the ground. Otherwise, turn the wheels a little once a month in order to prevent the tires from becoming degraded in one spot.
9. Cover the muffler outlet with a plastic bag to prevent moisture from entering it.
10. Remove the battery and fully charge it, or attach a maintenance charger to keep the battery optimally charged. **NOTICE: Confirm that the battery and its charger are compatible. Do not charge a VRLA battery with a conventional charger.**[ECA26330]

## TIP

- If the battery will be removed, charge it once a month and store it in a temperate location between 0-30 °C (32-90 °F).
- See page 9-26 for more information on charging and storing the battery.

# Specifications

## Dimensions:

- Overall length:  
2175 mm (85.6 in)
- Overall width:  
900 mm (35.4 in)
- Overall height:  
1440/1530 mm (56.7/60.2 in)
- Seat height:  
845/860 mm (33.3/33.9 in)
- Wheelbase:  
1500 mm (59.1 in)
- Ground clearance:  
135 mm (5.31 in)
- Minimum turning radius:  
2.9 m (9.51 ft)

## Weight:

- Curb weight:  
232 kg (513 lb)

## Engine:

- Combustion cycle:  
4-stroke
- Cooling system:  
Liquid cooled
- Valve train:  
DOHC
- Cylinder arrangement:  
Inline
- Number of cylinders:  
3-cylinder
- Displacement:  
890 cm<sup>3</sup>
- Bore × stroke:  
78.0 × 62.1 mm (3.07 × 2.44 in)

- Starting system:  
Electric starter

## Engine oil:

- Recommended brand:



- SAE viscosity grades:  
10W-40
- Recommended engine oil grade:  
API service SG type or higher, JASO standard MA
- Engine oil quantity:  
Oil change:  
2.80 L (2.96 US qt, 2.46 Imp.qt)
- With oil filter removal:  
3.20 L (3.38 US qt, 2.82 Imp.qt)

## Coolant quantity:

- Coolant reservoir (up to the maximum level mark):  
0.28 L (0.30 US qt, 0.25 Imp.qt)
- Radiator (including all routes):  
1.72 L (1.82 US qt, 1.51 Imp.qt)

## Fuel:

- Recommended fuel:  
Unleaded gasoline (E10 acceptable)
- Octane number (RON):  
95
- Fuel tank capacity:  
19 L (5.0 US gal, 4.2 Imp.gal)
- Fuel reserve amount:  
3.7 L (0.98 US gal, 0.81 Imp.gal)

## Fuel injection:

- Throttle body:  
ID mark:  
BME1

## Drivetrain:

- Gear ratio:  
1st:  
2.571 (36/14)
- 2nd:  
1.947 (37/19)
- 3rd:  
1.619 (34/21)
- 4th:  
1.381 (29/21)
- 5th:  
1.190 (25/21)
- 6th:  
1.037 (28/27)

## Front tire:

- Type:  
Tubeless
- Size:  
120/70ZR17M/C (58W)
- Manufacturer/model:  
BRIDGESTONE/BATTLAX SPORT TOUR-  
ING T32F

## Rear tire:

- Type:  
Tubeless
- Size:  
180/55ZR17M/C (73W)
- Manufacturer/model:  
BRIDGESTONE/BATTLAX SPORT TOUR-  
ING T32R

**Loading:**

Maximum load:  
197 kg (434 lb)  
(Total weight of rider, passenger, cargo and accessories)

Auxiliary light:

LED

License plate light:

5.0 W

**Front brake:**

Type:  
Hydraulic dual disc brake

**Rear brake:**

Type:  
Hydraulic single disc brake

**Front suspension:**

Type:  
Telescopic fork

**Rear suspension:**

Type:  
Swingarm (link suspension)

**Electrical system:**

System voltage:  
12 V

**Battery:**

Model:  
YTZ10S  
Voltage, capacity:  
12 V, 8.6 Ah (10 HR)

**Bulb wattage:**

Headlight:  
LED  
Brake/tail light:  
LED  
Front turn signal light:  
LED  
Rear turn signal light:  
LED

# Consumer information

EAU53562

## Identification numbers

Record the vehicle identification number, engine serial number, and the model label information in the spaces provided below. These identification numbers are needed when registering the vehicle with the authorities in your area and when ordering spare parts from a Yamaha dealer.

VEHICLE IDENTIFICATION NUMBER:

ENGINE SERIAL NUMBER:

MODEL LABEL INFORMATION:

## Vehicle identification number

EAU26401

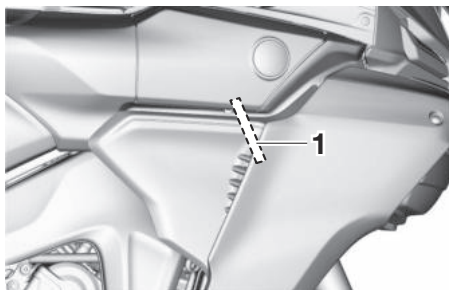

1. Vehicle identification number

The vehicle identification number is stamped into the steering head pipe. Record this number in the space provided.

### TIP

The vehicle identification number is used to identify your motorcycle and may be used to register your motorcycle with the licensing authority in your area.

## Engine serial number

EAU26442

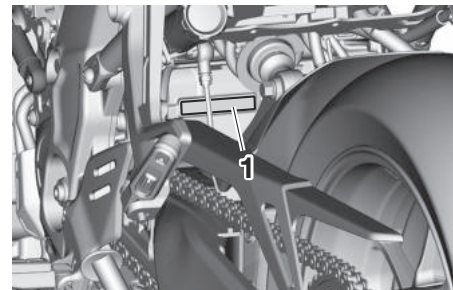

1. Engine serial number

The engine serial number is stamped into the crankcase.

## Model label

EAU26471

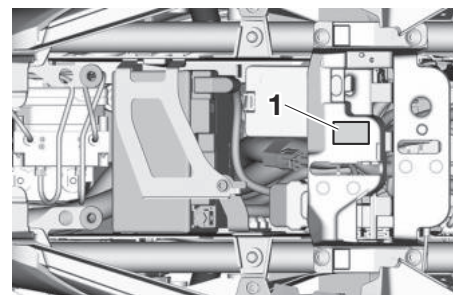

1. Model label

The model label is affixed to the frame under the rider seat. (See page 6-44.) Record the information on this label in the space provided. This information will be needed when ordering spare parts from a Yamaha dealer.

## Diagnostic connector

EAU69910

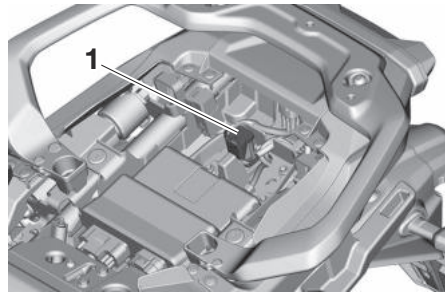

1. Diagnostic connector

The diagnostic connector is located as shown.

# Consumer information

---

EUA1021

## Use of your data

This is a brief summary of how Yamaha (Yamaha Motor Co., Ltd., and the local subsidiaries) uses your data. For more details for Yamaha's use of your data, please see our Privacy Policy.

<https://global.yamaha-motor.com/en/privacy/>

## What data we collect? and How we collect your data?

This vehicle collects three types of data through integrated Engine Control Units (ECU):

(1) Vehicle Identification Number (VIN); (2) live data showing the performance of the vehicle such as engine/motor operating state, vehicle speed, mileage; and (3) other data showing the status of the vehicle such as diagnostic trouble code (DTC).

The collected data will be uploaded to server at Yamaha Motor Co., Ltd. by attaching a special Yamaha diagnostic tool to the vehicle, only when maintenance checks or service procedures are performed.

## How will we use your data?

Yamaha use collected data from your vehicle, (1) to conduct adequate maintenance service including diagnostics, (2) to implement proper warranty claim judgement, (3) to conduct research and development of vehicle, (4) to provide and improve quality of products, features, and services, (5) to ensure our business purpose, and (6) to comply with legal obligations or lawful orders, and to establish or defend legal claims.

## How we share your data?

We may share your data with: (i) our subsidiaries, affiliates, and business partners; (ii) dealers and distributors in your country or region, and (iii) contractors within the scope necessary to achieve the purpose of use described above.

## How to contact us

Any questions or complaints regarding the processing of your Personal Data can be submitted in writing to the local subsidiaries.

<https://global.yamaha-motor.com/link/>

**The SOLE PURPOSE of above provided contact information is TO RESPOND DATA PROCESSING INQUIRY AND OTHER KINDS OF INQUIRIES WILL NOT BE RESPONDED.** Please provide the following information for the proper

## Consumer information

---

handling of your inquiry: **(1) Your Name; (2) Your Email Address; (3) Your Country of Residence; and (4) Your VIN.** We will use your personal information provided only for the purpose of supporting your data processing inquiry.

# Index

## A

- ABS warning light..... 6-5
- ACC system operation..... 4-14
- Adaptive Cruise Control (ACC) system..... 4-12
- Adaptive Cruise Control/YVSL switches..... 6-2
- Air filter element..... 9-13
- Anti-lock brake system (ABS)..... 4-21

## B

- Battery..... 9-26
- BC (Brake control system)..... 4-26
- Brake fluid level, checking..... 9-18
- Brake fluid, changing..... 9-20
- Brake lever..... 6-41
- Brake lever free play, checking..... 9-17
- Brake lever, checking and lubricating..... 9-23
- Brake light switches..... 9-17
- Brake pedal..... 6-41
- Brake pedal, checking and lubricating..... 9-23
- Brake system..... 4-20
- BSD (blind spot detection)..... 4-10
- BSR (Back slip regulator)..... 4-26

## C

- Cables, checking and lubricating..... 9-22
- Canister..... 9-9
- Care..... 10-1
- Catalytic converter..... 6-44
- Centerstand and sidestand, checking and lubricating..... 9-24
- Connection troubleshooting..... 5-10
- Coolant..... 9-12
- Cornering lights..... 4-5

## D

- DC connectors..... 6-51
- Diagnostic connector..... 12-2

- Display..... 6-7
- Drive chain slack..... 9-20
- Drive chain, cleaning and lubricating..... 9-22

## E

- EBM (Engine brake management)..... 4-25
- Emergency mode..... 9-35
- Engine break-in..... 8-1
- Engine idling speed, checking..... 9-13
- Engine oil..... 9-9
- Engine overheating..... 9-34
- Engine serial number..... 12-1
- Engine trouble warning light..... 6-4
- ESS (emergency stop signaling) system..... 4-28

## F

- FCW (Forward Collision Warning)..... 4-9
- Front and rear brake pads, checking..... 9-18
- Front fork, checking..... 9-25
- Fuel..... 6-42
- Fuel consumption, tips for reducing..... 8-5
- Fuel tank cap opening and closing..... 4-40
- Fuel tank overflow hose..... 6-43
- Fuses, replacing..... 9-27

## H

- Handlebar position, adjusting..... 6-49
- Handlebar switches..... 6-1
- Hazard switch..... 6-2
- Headlight switch..... 6-1
- Helmets..... 2-5
- High beam indicator light..... 6-4
- Horn switch..... 6-2

## I

- Identification numbers..... 12-1
- Ignition circuit cut-off system..... 6-53
- Indicator lights and warning lights..... 6-4

- Initial setup..... 5-3

## J

- Joystick and home button..... 6-3

## K

- Key, handling of smart and mechanical key..... 4-33

## L

- Labels, location..... 1-1
- License plate light bulb, replacing..... 9-30
- LIF (Lift control system)..... 4-25

## M

- Main switch..... 4-37
- Maintenance and lubrication, periodic..... 9-4
- Maintenance, emission control system..... 9-3
- Matrix LED headlight..... 4-1
- Matte color, caution..... 10-1
- Millimeter-wave radar..... 4-5
- Model label..... 12-1

## N

- Navigation system: Garmin Motorize..... 5-7
- Neutral indicator light..... 6-4

## O

- Operating range of the smart key system..... 4-32

## P

- Parking..... 8-5
- Part locations..... 3-1
- Pop-up menu system..... 6-20
- Pre-ride Suspension Damping system..... 4-29
- PWR (Power delivery mode)..... 4-23

## R

- Radar-linked UBS..... 4-22
- Rider footrest position, adjusting..... 6-47
- Rider intervention request..... 4-8
- Rider seat height, adjusting..... 6-45

<b>S</b>	
Safety information.....	2-1
SC (Stability control system).....	4-23
SCS (Slide control system).....	4-24
Seats.....	6-44
Shift indicator light.....	6-5
Shift Indicator settings.....	6-37
Shift lever.....	6-3
Shifting.....	8-3
Shifting gears by hand.....	9-31
Sidecase support holder.....	6-49
Sidestand.....	6-52
Smart features (communication control unit).....	5-1
Smart key.....	4-35
Smart key battery, replacing.....	4-35
Smart key system.....	4-31
Smart key system indicator light.....	6-6
Smart key system, troubleshooting.....	9-31
Spark plugs, checking.....	9-8
Special features.....	4-1
Specifications.....	11-1
Stability control indicator light.....	6-6
Starting the engine.....	8-2
Steering, checking.....	9-25
Stop/Run/Start switch.....	6-2
Storage.....	10-3
Storage compartment.....	6-48
SUS (Electronically controlled suspension damping system).....	4-25
Suspension, adjusting the front and rear.....	6-49
Swingarm pivots, lubricating.....	9-24
<b>T</b>	
TCS (Traction control system).....	4-24
Telephone.....	5-8
Throttle grip, checking and lubricating.....	9-23
Tire pressure warning light.....	6-6
Tires.....	9-14
Tool kits.....	9-2
TPMS (Tire pressure monitoring system)....	4-31
Troubleshooting.....	9-31
Troubleshooting chart.....	9-33
Turn signal indicator lights.....	6-4
Turn signal switch.....	6-2
<b>U</b>	
UBS warning light.....	6-5
Unified brake system (UBS).....	4-21
USB jack(s).....	6-51
Use, your vehicle data.....	12-3
<b>V</b>	
Valve clearance.....	9-14
Vehicle identification number.....	12-1
Vehicle lights.....	9-29
VHC (Vehicle hold control).....	4-30
<b>W</b>	
Wheel bearings, checking.....	9-26
Wheels.....	9-16
<b>Y</b>	
Y-AMT (Yamaha-Automated Manual Transmission).....	4-27
Y-AMT malfunction indicator light.....	6-4
Y-AMT switch.....	6-3
Yamaha Motorcycle Connect app.....	5-2
Yamalube.....	9-11
YRC (Yamaha Ride Control).....	4-23
YRC mode button.....	6-2
YVSL.....	4-18







PRINTED IN JAPAN  
2025.12-0.3×1 CR (E)