



OWNER'S MANUAL

**⚠ Read this manual carefully
before operating this vehicle.**



MOTORCYCLE

YZF890 (R9)

BKN-2U199-E1

Location of important labels	1
Safety information	2
Description	3
Special features	4
Smartphone Connectivity System	5
Instrument and control functions	6
For your safety – pre-operation checks	7
Operation and important riding points	8
Periodic maintenance and adjustment	9
Motorcycle care and storage	10
Specifications	11
Consumer information	12
Index	13

 Read this manual carefully before operating this vehicle. This manual should stay with this vehicle if it is sold.



เครื่องโทรคมนาคมและอุปกรณ์นี้ มีความสอดคล้องตาม มาตรฐานหรือข้อกำหนดทางเทคนิคของ กสทช.

Use of trade marks

The Bluetooth[®] word mark and logos are registered trademarks owned by Bluetooth SIG, Inc.

iOS is a registered trademark or trademark of Cisco Systems, Inc. and/or its affiliates in the United States and certain other countries.

Garmin StreetCross[™] is a trademark of Garmin Ltd.

Introduction

EAU10103

Welcome to the Yamaha world of motorcycling!

As the owner of the YZF890, you are benefiting from Yamaha's vast experience and newest technology regarding the design and manufacture of high-quality products, which have earned Yamaha a reputation for dependability.

Please take the time to read this manual thoroughly, so as to enjoy all advantages of your YZF890. The Owner's Manual does not only instruct you in how to operate, inspect and maintain your motorcycle, but also in how to safeguard yourself and others from trouble and injury.

In addition, the many tips given in this manual will help keep your motorcycle in the best possible condition. If you have any further questions, do not hesitate to contact your Yamaha dealer.

The Yamaha team wishes you many safe and pleasant rides. So, remember to put safety first!

Yamaha continually seeks advancements in product design and quality. Therefore, while this manual contains the most current product information available at the time of printing, there may be minor discrepancies between your motorcycle and this manual. If there is any question concerning this manual, please consult a Yamaha dealer.

EWA10032







Please read this manual carefully and completely before operating this motorcycle.

Important manual information

EAU10134

Particularly important information is distinguished in this manual by the following notations:

	This is the safety alert symbol. It is used to alert you to potential personal injury hazards. Obey all safety messages that follow this symbol to avoid possible injury or death.
	A WARNING indicates a hazardous situation which, if not avoided, could result in death or serious injury.
	A NOTICE indicates special precautions that must be taken to avoid damage to the vehicle or other property.
	A TIP provides key information to make procedures easier or clearer.

*Product and specifications are subject to change without notice.

Important manual information

EAU10202

**YZF890
OWNER'S MANUAL
©2026 by Yamaha Motor Co., Ltd.
1st edition, September 2025
All rights reserved.
Any reprinting or unauthorized use
without the written permission of
Yamaha Motor Co., Ltd.
is expressly prohibited.
Printed in Japan.**

Table of contents

Location of important labels	1-1	Display	6-8	Tips for reducing fuel consumption.....	8-5
Safety information	2-1	Menu system.....	6-21	Parking.....	8-5
Helmets.....	2-5	Clutch lever	6-41	Periodic maintenance and adjustment	9-1
Description	3-1	Shift pedal	6-42	Tool kit	9-2
Left view	3-1	Brake lever	6-42	Periodic maintenance chart for the emission control system.....	9-3
Right view.....	3-2	Brake pedal	6-43	General maintenance and lubrication chart	9-4
Controls and instruments	3-3	Brake system.....	6-43	Removing and installing cowlings.....	9-8
Special features	4-1	Fuel tank cap	6-44	Checking the spark plugs	9-10
YRC (Yamaha Ride Control).....	4-1	Fuel	6-45	Canister.....	9-11
Cruise control system	4-6	Fuel tank overflow hose	6-46	Engine oil.....	9-11
Yamaha variable speed limiter (YVSL).....	4-9	Catalytic converter	6-47	Why Yamalube	9-14
ESS (emergency stop signaling) system	4-11	Seats	6-47	Coolant.....	9-14
Smartphone Connectivity System	5-1	Rider footrest position	6-49	Air filter element.....	9-16
Smart features: Introduction	5-1	Storage compartment	6-49	Checking the engine idling speed ...	9-16
Initial setup	5-3	Rear view mirrors.....	6-50	Valve clearance	9-16
Telephone.....	5-7	Adjusting the front fork	6-50	Tires	9-17
Connection troubleshooting	5-8	Adjusting the shock absorber assembly	6-53	Cast wheels.....	9-19
Instrument and control functions	6-1	DC connectors	6-55	Adjusting the clutch lever free play	9-19
Immobilizer system	6-1	USB Type-C jack	6-56	Checking the brake lever free play	9-20
Main switch/steering lock.....	6-2	Sidestand.....	6-57	Brake light switches.....	9-21
Handlebar switches.....	6-3	Ignition circuit cut-off system.....	6-57	Checking the front and rear brake pads	9-21
Indicator lights and warning lights	6-5	For your safety – pre-operation checks	7-1	Checking the brake fluid level	9-22
		Operation and important riding points	8-1	Changing the brake fluid.....	9-23
		Engine break-in	8-1		
		Starting the engine	8-2		
		Shifting.....	8-3		

Table of contents

Drive chain slack.....	9-24	Specifications	11-1
Cleaning and lubricating the drive chain.....	9-26	Consumer information	12-1
Checking and lubricating the ca- bles	9-26	Identification numbers.....	12-1
Checking and lubricating the throttle grip.....	9-27	Diagnostic connector	12-2
Checking and lubricating the brake and shift pedals	9-27	Use of your data.....	12-3
Checking and lubricating the brake and clutch levers	9-28	Index	13-1
Checking and lubricating the sidestand	9-28		
Lubricating the swingarm pivots.....	9-29		
Checking the front fork	9-29		
Checking the steering.....	9-30		
Checking the wheel bearings.....	9-30		
Battery.....	9-30		
Replacing the fuses	9-32		
Vehicle lights	9-34		
Replacing a license plate light bulb.....	9-34		
Supporting the motorcycle	9-35		
Troubleshooting	9-35		
Troubleshooting chart.....	9-36		
Motorcycle care and storage	10-1		
Matte color caution.....	10-1		
Care.....	10-1		
Storage	10-3		

Location of important labels

EAU10387

1

Read and understand all of the labels on your vehicle. They contain important information for safe and proper operation of your vehicle. Never remove any labels from your vehicle. If a label becomes difficult to read or comes off, a replacement label is available from your Yamaha dealer.

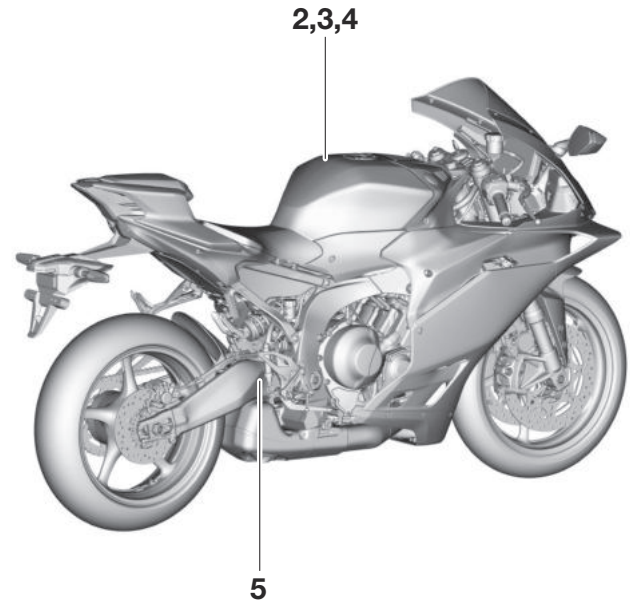
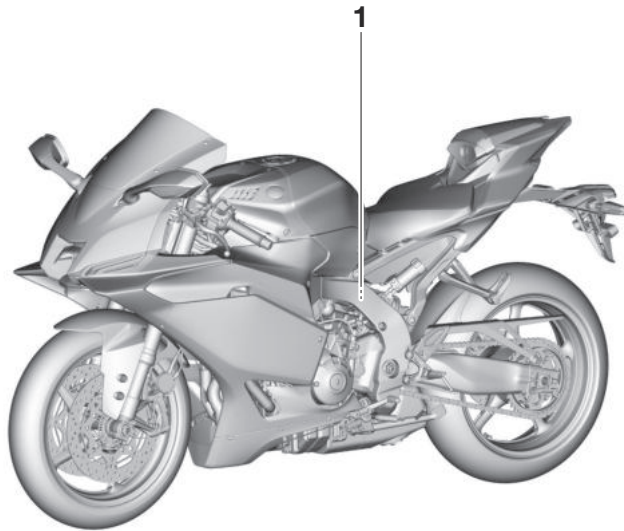

Location of important labels

1

1



2

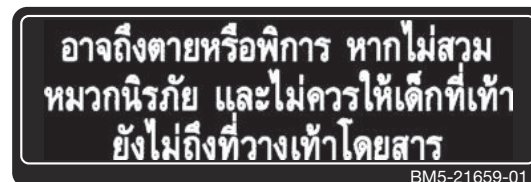

3



4

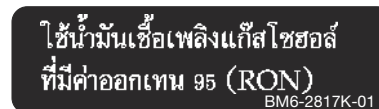

5

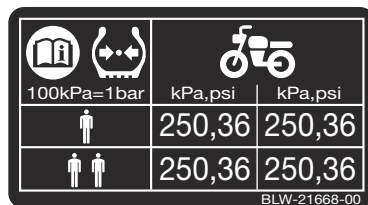

EAU1028D

Be a Responsible Owner

As the vehicle's owner, you are responsible for the safe and proper operation of your motorcycle.

Motorcycles are single-track vehicles. Their safe use and operation are dependent upon the use of proper riding techniques as well as the expertise of the operator. Every operator should know the following requirements before riding this motorcycle.

He or she should:

- Obtain thorough instructions from a competent source on all aspects of motorcycle operation.
- Observe the warnings and maintenance requirements in this Owner's Manual.
- Obtain qualified training in safe and proper riding techniques.
- Obtain professional technical service as indicated in this Owner's Manual and/or when made necessary by mechanical conditions.

- Never operate a motorcycle without proper training or instruction. Take a training course. Beginners should receive training from a certified instructor. Contact an authorized motorcycle dealer to find out about the training courses nearest you.

Safe Riding

Perform the pre-operation checks each time you use the vehicle to make sure it is in safe operating condition. Failure to inspect or maintain the vehicle properly increases the possibility of an accident or equipment damage. See page 7-1 for a list of pre-operation checks.

- This motorcycle is designed to carry the operator and a passenger.
- The failure of motorists to detect and recognize motorcycles in traffic is the predominating cause of automobile/motorcycle accidents. Many accidents have been caused by an automobile driver who did not see the motorcycle. Making yourself conspicuous appears to

be very effective in reducing the chance of this type of accident.

Therefore:

- Wear a brightly colored jacket.
- Use extra caution when you are approaching and passing through intersections, since intersections are the most likely places for motorcycle accidents to occur.
- Ride where other motorists can see you. Avoid riding in another motorist's blind spot.
- Never maintain a motorcycle without proper knowledge. Contact an authorized motorcycle dealer to inform you on basic motorcycle maintenance. Certain maintenance can only be carried out by certified staff.
- Many accidents involve inexperienced operators. In fact, many operators who have been involved in accidents do not even have a current motorcycle license.
- Make sure that you are qualified and that you only lend your motorcycle to other qualified operators.

Safety information

2

- Know your skills and limits. Staying within your limits may help you to avoid an accident.
- We recommend that you practice riding your motorcycle where there is no traffic until you have become thoroughly familiar with the motorcycle and all of its controls.
- Many accidents have been caused by error of the motorcycle operator. A typical error made by the operator is veering wide on a turn due to excessive speed or undercornering (insufficient lean angle for the speed).
 - Always obey the speed limit and never travel faster than warranted by road and traffic conditions.
 - Always signal before turning or changing lanes. Make sure that other motorists can see you.
- The posture of the operator and passenger is important for proper control.
 - The operator should keep both hands on the handlebar and both feet on the operator foot-

ests during operation to maintain control of the motorcycle.

- The passenger should always hold onto the operator, the seat strap or grab bar, if equipped, with both hands and keep both feet on the passenger footrests. Never carry a passenger unless he or she can firmly place both feet on the passenger footrests.
- Never ride under the influence of alcohol or other drugs.
- This motorcycle is designed for on-road use only. It is not suitable for off-road use.

Protective Apparel

The majority of fatalities from motorcycle accidents are the result of head injuries. The use of a safety helmet is the single most critical factor in the prevention or reduction of head injuries.

- Always wear an approved helmet.
- Wear a face shield or goggles. Wind in your unprotected eyes could contribute to an impairment of vision that could delay seeing a hazard.

- The use of a jacket, heavy boots, trousers, gloves, etc., is effective in preventing or reducing abrasions or lacerations.
- Never wear loose-fitting clothes, otherwise they could catch on the control levers, footrests, or wheels and cause injury or an accident.
- Always wear protective clothing that covers your legs, ankles, and feet. The engine or exhaust system become very hot during or after operation and can cause burns.
- A passenger should also observe the above precautions.

Avoid Carbon Monoxide Poisoning

All engine exhaust contains carbon monoxide, a deadly gas. Breathing carbon monoxide can cause headaches, dizziness, drowsiness, nausea, confusion, and eventually death.

Carbon Monoxide is a colorless, odorless, tasteless gas which may be present even if you do not see or smell any engine exhaust. Deadly levels of carbon monoxide can collect rapidly and you can quickly be overcome and unable to save yourself. Also, deadly

levels of carbon monoxide can linger for hours or days in enclosed or poorly ventilated areas. If you experience any symptoms of carbon monoxide poisoning, leave the area immediately, get fresh air, and SEEK MEDICAL TREATMENT.

- Do not run engine indoors. Even if you try to ventilate engine exhaust with fans or open windows and doors, carbon monoxide can rapidly reach dangerous levels.
- Do not run engine in poorly ventilated or partially enclosed areas such as barns, garages, or carports.
- Do not run engine outdoors where engine exhaust can be drawn into a building through openings such as windows and doors.

Loading

Adding accessories or cargo to your motorcycle can adversely affect stability and handling if the weight distribution of the motorcycle is changed. To avoid the possibility of an accident, use extreme caution when adding cargo or accessories to your motorcycle. Use

extra care when riding a motorcycle that has added cargo or accessories. Here, along with the information about accessories below, are some general guidelines to follow if loading cargo to your motorcycle:

The total weight of the operator, passenger, accessories and cargo must not exceed the maximum load limit.

Operation of an overloaded vehicle could cause an accident.

<p>Maximum load: 164 kg (363 lb)</p>

When loading within this weight limit, keep the following in mind:

- Cargo and accessory weight should be kept as low and close to the motorcycle as possible. Securely pack your heaviest items as close to the center of the vehicle as possible and make sure to distribute the weight as evenly as possible on both sides of the motorcycle to minimize imbalance or instability.
- Shifting weights can create a sudden imbalance. Make sure that ac-

cessories and cargo are securely attached to the motorcycle before riding. Check accessory mounts and cargo restraints frequently.

- Properly adjust the suspension for your load (suspension-adjustable models only), and check the condition and pressure of your tires.
- Never attach any large or heavy items to the handlebar, front fork, or front fender. These items, including such cargo as sleeping bags, duffel bags, or tents, can create unstable handling or a slow steering response.
- **This vehicle is not designed to pull a trailer or to be attached to a sidecar.**

Genuine Yamaha Accessories

Choosing accessories for your vehicle is an important decision. Genuine Yamaha accessories, which are available only from a Yamaha dealer, have been designed, tested, and approved by Yamaha for use on your vehicle.

Safety information

2

Many companies with no connection to Yamaha manufacture parts and accessories or offer other modifications for Yamaha vehicles. Yamaha is not in a position to test the products that these aftermarket companies produce. Therefore, Yamaha can neither endorse nor recommend the use of accessories not sold by Yamaha or modifications not specifically recommended by Yamaha, even if sold and installed by a Yamaha dealer.

Aftermarket Parts, Accessories, and Modifications

While you may find aftermarket products similar in design and quality to genuine Yamaha accessories, recognize that some aftermarket accessories or modifications are not suitable because of potential safety hazards to you or others. Installing aftermarket products or having other modifications performed to your vehicle that change any of the vehicle's design or operation characteristics can put you and others at greater risk of serious injury or death. You are responsible for injuries related to changes in the vehicle.

Keep the following guidelines in mind, as well as those provided under “Loading” when mounting accessories.

- Never install accessories or carry cargo that would impair the performance of your motorcycle. Carefully inspect the accessory before using it to make sure that it does not in any way reduce ground clearance or cornering clearance, limit suspension travel, steering travel or control operation, or obscure lights or reflectors.
- Accessories fitted to the handlebar or the front fork area can create instability due to improper weight distribution or aerodynamic changes. If accessories are added to the handlebar or front fork area, they must be as lightweight as possible and should be kept to a minimum.
- Bulky or large accessories may seriously affect the stability of the motorcycle due to aerodynamic effects. Wind may attempt to lift the motorcycle, or the motorcycle may become unstable in cross winds. These

accessories may also cause instability when passing or being passed by large vehicles.

- Certain accessories can displace the operator from his or her normal riding position. This improper position limits the freedom of movement of the operator and may limit control ability, therefore, such accessories are not recommended.
- Use caution when adding electrical accessories. If electrical accessories exceed the capacity of the motorcycle's electrical system, an electric failure could result, which could cause a dangerous loss of lights or engine power.

Aftermarket Tires and Rims

The tires and rims that came with your motorcycle were designed to match the performance capabilities and to provide the best combination of handling, braking, and comfort. Other tires, rims, sizes, and combinations may not be appropriate. See page 9-17 for tire specifications and for information on servicing and replacing your tires.

Transporting the Motorcycle

Be sure to observe following instructions before transporting the motorcycle in another vehicle.

- Remove all loose items from the motorcycle.
- Check that the fuel cock (if equipped) is in the off position and that there are no fuel leaks.
- Shift the transmission into gear (for models with a manual transmission).
- Secure the motorcycle with tie-downs or suitable straps that are attached to solid parts of the motorcycle, such as the frame or upper front fork triple clamp (and not, for example, to rubber-mounted handlebars or turn signals, or parts that could break). Choose the location for the straps carefully so the straps will not rub against painted surfaces during transport.
- The suspension should be compressed somewhat by the tie-downs, if possible, so that the motorcycle will not bounce excessively during transport.

Helmets

EAUJ0033

Operating this vehicle without an approved motorcycle helmet increases your chances of a severe head injury or death in the event of an accident. The majority of fatalities from motorcycle or scooter accidents are the result of head injuries. The use of a safety helmet is the single most critical factor in the prevention or reduction of head injuries.

Always select an approved motorcycle helmet

Pay attention to the following when choosing a motorcycle helmet.

- The helmet must meet the safety standard “TIS”.
- The helmet size must match the size of the rider’s head.
- Never subject a helmet to heavy shocks.

Wearing the helmet correctly

Always connect the chin strap. In the case of an accident, the helmet has a much less chance of coming off if the chin strap is connected.

Correct usage



ZAUU0003

Wrong usage



ZAUU0007

Types of helmets and their usage

- Half-type: use only for riding at low speeds

Safety information

2



ZAUU0004

- Full-type: use only for riding at low to mid-range speeds



ZAUU0006



ZAUU0005

- Full-face-type: use for riding at mid-range to high speeds

Left view

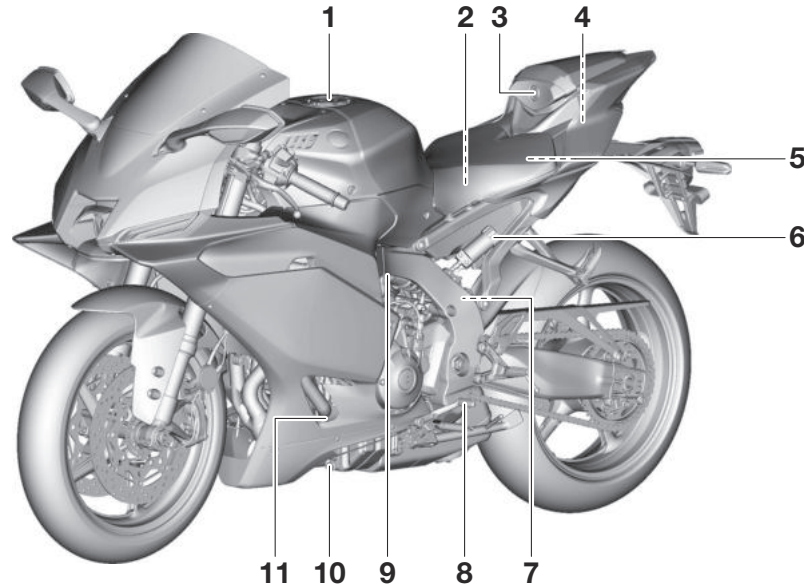

1. Fuel tank cap (page 6-44)
2. Battery (page 9-30)
3. Seat lock (page 6-47)
4. USB Type-C jack (page 6-56)
5. Fuses (page 9-32)
6. Spring preload adjuster (page 6-53)
7. Rebound damping force adjuster (page 6-53)
8. Shift pedal (page 6-42)
9. Compression damping force adjuster (page 6-53)
10. Engine oil drain bolt (page 9-11)
11. Oil filter cartridge (page 9-11)

Description

EAU10421

Right view

3

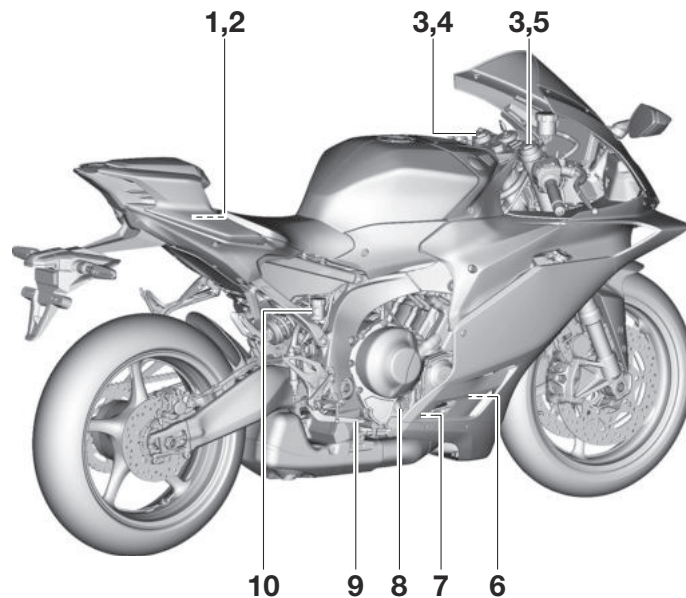

1. Tool kit (page 9-2)
2. Storage compartment (page 6-49)
3. Spring preload adjuster (page 6-50)
4. Compression damping force adjuster (page 6-50)
5. Rebound damping force adjuster (page 6-50)
6. Coolant reservoir (page 9-14)
7. Engine oil level check window (page 9-11)
8. Engine oil filler cap (page 9-11)
9. Brake pedal (page 6-43)
10. Rear brake fluid reservoir (page 9-22)

Controls and instruments

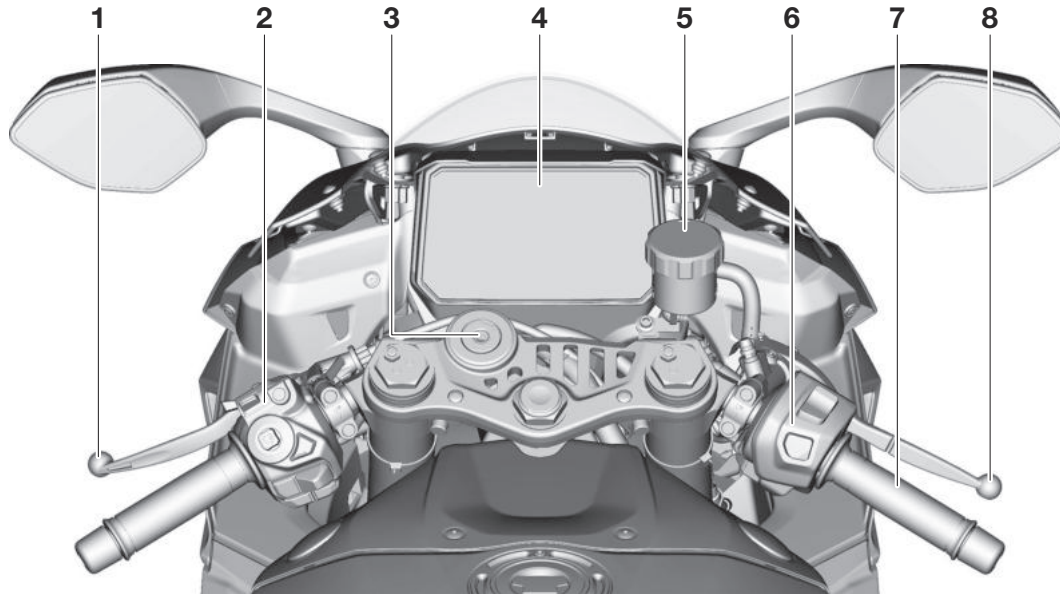

1. Clutch lever (page 6-41)
2. Left handlebar switches (page 6-3)
3. Main switch/steering lock (page 6-2)
4. Display (page 6-8)
5. Front brake fluid reservoir (page 9-22)
6. Right handlebar switches (page 6-3)
7. Throttle grip (page 9-27)
8. Brake lever (page 6-42)

Special features

4

YRC (Yamaha Ride Control)

EAU5415

YRC is a system that incorporates numerous sensors and controls to support an improved riding experience. The vehicle senses and can react to forces along the longitudinal (front-to-back), lateral (left-to-right), and vertical (up-and-down) axes. Lean angle and G-force accelerations are also detected. This information is processed multiple times a second and the related physical systems are automatically adjusted as necessary. The following functions represent individual YRC items which can be turned on/off or adjusted to suit various riders and riding conditions. For setting details, see page 6-30.

WARNING

EWA18221

The Yamaha Ride Control (YRC) system is not a substitute for the use of proper riding techniques or the expertise of the operator. This system cannot prevent loss of control caused by rider errors such as traveling faster than warranted by road and traffic conditions, including loss

of traction due to excessive speed when entering turns, when accelerating hard at a sharp lean angle, or while braking, and it cannot prevent front wheel slip or front wheel lift. As with any motorcycle, always ride within in your limits, be aware of surrounding conditions, and ride appropriately for those conditions. Become thoroughly familiar with the way the motorcycle handles with various YRC settings before attempting more advanced maneuvers.

SC (Stability control system)

SC consists of TCS (traction control system), SCS (slide control system), LIF (lift control system) and BSR (back slip regulator). These can be independently adjusted in the menu system (see page 6-30), or turned on/off all together by turning off TCS in the menu system (see page 6-34).

When any of the SC systems engage while riding, the stability control indicator light “**sc**” will flash (see page 6-7).

PWR (Power delivery mode)

PWR consists of four different control maps which regulate throttle valve opening in relation to the degree of throttle grip operation, thus providing you with a selection of modes to fit your preferences and the riding environment.

Level 1 - Sporty engine response.

Level 2 - Moderate engine response.

Level 3 - Mild engine response.

Level 4 - Rainy days or whenever less engine power is desirable.

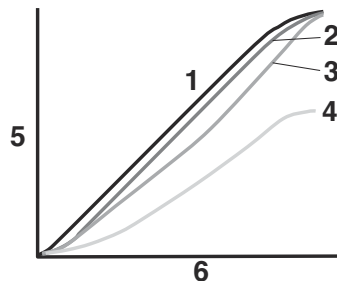

1. Level 1
2. Level 2
3. Level 3
4. Level 4
5. Throttle valve opening
6. Throttle grip operation

TCS (Traction control system)

TCS helps maintain traction when accelerating. If sensors detect that the rear wheel is starting to slip (uncontrolled spinning), TCS assists by regulating engine power as needed until traction is restored.

TCS automatically adjusts according to the vehicle's lean angle. To maximize acceleration, when the vehicle is upright a less amount of traction control is applied. When cornering, a greater amount of traction control is applied.

TCS has multiple setting levels. The higher the setting level, the greater the amount of system intervention.



Traction control system

TIP

- TCS may engage when the vehicle travels over a bump.

- You may notice slight changes in engine and exhaust sounds when TCS or other YRC systems engage.
- When the main switch is turned on, TCS automatically turns on. TCS can be turned on/off manually only when the main switch is turned on and the vehicle is stopped.
- Turn TCS off to help free the rear wheel if the vehicle gets stuck in mud, sand, or other soft surfaces.

⚠ WARNING

EWA15433

The traction control system is not a substitute for riding appropriately for the conditions. Traction control cannot prevent loss of traction due to excessive speed when entering turns, when accelerating hard at a sharp lean angle, or while braking, and cannot prevent front wheel slipping. As with any vehicle, approach surfaces that may be slippery with caution and avoid especially slippery surfaces.

NOTICE

Use only the specified tires. (See page 9-17.) Using different sized tires will prevent the traction control system from controlling tire rotation accurately.

SCS (Slide control system)

SCS regulates engine power output when a sideward slide is detected in the rear wheel. It adjusts power output based on the lean angle of the vehicle. This system supports TCS (traction control system) to contribute to a smoother ride.

SCS has multiple setting levels. The higher the setting level, the greater the amount of system intervention to strongly reduce lateral wheel slippage. Level 1 - Suitable for more sporty riding.

Level 2 - Suitable for street riding.

Level 3 - Suitable for riding on wet or slippery surfaces.

Special features

4

LIF (Lift control system)

LIF reduces the rate at which the front wheel will continue to rise during extreme acceleration, such as during starts or out-of-corner exits. When front-wheel lift is detected, engine power is regulated to slow front-wheel lift while still providing good acceleration.

LIF can be set to 1, 2, and 3.

The higher the setting level, the greater the amount of system intervention to reduce wheel lift.

Level 1 - Least lift control. Suitable for more sporty riding.

Level 2 - More lift control. Suitable for sporty riding.

Level 3 - Most lift control. Suitable for street riding.

EBM (Engine brake management)

EBM reduces engine torque when decelerating. The fuel injection, ignition timing, and electronic throttle valve are electronically adjusted by the ECU.

EBM can be set to 1 or 2.

Level 1 - The least system intervention and therefore the most engine braking.

Level 2 - The most system intervention and therefore the least engine braking.

EWA20880



Make sure the engine has sufficiently slowed before shifting to a lower gear. Engaging a lower gear when the engine speed is too high could make the rear wheel lose traction. This could cause loss of control, an accident and injury. It could also cause engine or drivetrain damage.

QS (Quick shifter)

QS allows for clutch lever-less, electronically-assisted shifting. When the sensor on the shift rod detects the appropriate motion in the shift pedal, engine power output is momentarily adjusted to allow for the gear change to occur.

QS does not operate when the clutch lever is pulled, therefore normal shifting can be done even when QS is set to on. Check the quick shifter indicator for current status and usability information.

Quick shifter usability	Indicator
Upshifting OK	QS ▲▼
Downshifting OK	QS ▲▼
Quick shifter cannot be used	QS ▲▼
Quick shifter turned off	QS ▲▼

Upshifting conditions

- Vehicle speed of at least 15 km/h (9 mi/h)
- Engine speed of at least 2000 r/min
- Engine speed sufficiently below the red zone

Downshifting conditions

- Vehicle speed of at least 15 km/h (9 mi/h)
- Engine speed of at least 1600 r/min
- Engine speed sufficiently away from red zone

TIP

- “QS ▲” and “QS ▼” can be individually set.
- Shifting into or out of neutral must be done using the clutch lever.

BC (Brake control system)

BC regulates hydraulic brake pressure for the front and rear wheels when the brakes are applied. This system has two settings:

- OFF: Only the standard ABS (anti-lock brake system), which adjusts brake pressure based on vehicle speed and wheel speed data. The standard ABS (anti-lock brake system) designed to engage and maximize braking when the vehicle is upright.
- ON: ABS (Anti-lock brake system) and cornering assist braking are both active. In addition to the standard ABS, it suppresses the increase in brake pressure when unavoidable abrupt braking occurs during cornering, making the vehicle's recovery to upright position more gradual. Also, additional data from the IMU regulates applied brake power depending on lean angle in order to increase the feeling of stability and to suppress wheel lock.

See page 6-43 for more information on the Brake System.

TIP

- When the rear wheel anti-lock braking system is disabled, the BC (brake control system) is also disabled.
- For skilled riders or when track riding, a variety of conditions may cause BC to brake faster than expected for a desired cornering speed or intended cornering line.
- BC is automatically OFF when entering TRACK theme. However it can be turned on manually in the settings menu.

EWA22532

WARNING

- **Even with BC ON, strong braking during cornering may result in wheel slippage and loss of balance. Please decelerate sufficiently before entering corners.**
- **Do not use BC on roads other than public roads, as BC may not operate properly and an accident may result.**

BSR (Back slip regulator)

BSR helps maintain traction when decelerating and/or downshifting in low traction conditions. If sensors detect that the rear wheel is starting to slip or lock, BSR assists by regulating engine power as needed until traction is restored.

TIP

- BSR may engage when the vehicle travels over a bump.
- You may notice slight changes in engine and exhaust sounds when BSR or other YRC systems engage.
- For skilled riders or those engaging in track riding, various conditions may lead BSR to influence the vehicle's behavior differently from what the rider anticipates.

EWA22700

WARNING

The back slip regulator is not a substitute for riding appropriately for the conditions. The back slip regulator cannot prevent loss of traction due to excessive speed when entering turns or braking and cannot prevent

Special features

front wheel slippage. As with any vehicle, approach surfaces that may be slippery with caution and avoid especially slippery surfaces.

ECA28580

NOTICE

Use only the specified tires. (See page 9-17.) Using different sized tires will prevent the back slip regulator from controlling tire rotation accurately.

LCS (Launch control system)

LCS helps the rider achieve smooth and swift launches from the starting grid. It keeps engine speed from rising too high when launching, even when the throttle grip is fully turned. LCS regulates engine power output in conjunction with the TCS (traction control system) and LIF (lift control) systems for optimal traction and reduced wheel lift. LCS can be set to 1, 2, or OFF.

Level 1 - keeps engine speed from rising above 9000 r/min.

Level 2 - keeps engine speed from rising above 8000 r/min.

OFF - LCS disabled.

ECA22951

NOTICE

Even when using LCS, the clutch lever must be released gradually to avoid clutch damage, and/or unexpected vehicle behavior.

TIP

- LCS is intended for track use on closed circuit race tracks only.
- LCS is only available if LIF and TCS are ON.

How to use LCS:

1. Enter TRACK theme.
2. Each YRC TRACK preset has an LCS option that can be set to OFF, level 1, or level 2. If the currently selected YRC TRACK preset has LCS set to OFF, open the menu system using the home button “” is visible in grey, the

launch control system is on standby.



If the launch control system indicator is OFF, one or more of the following is true:

- LCS is set to OFF.
 - TCS and/or LIF are turned OFF.
4. From standby, long press the “MODE” switch or open the menu system using the home button “

Launch control system indicator “” will flash and turn solid to indicate the LCS is active.

5. Open the throttle until the desired r/min (limited based on the selected LCS level 1 or 2) and gently release the clutch.
6. After launching, the launch control system indicator “” will stay on until the brakes are activated or the throttle is closed.

TIP

The Launch control system will stay active “” for 15 seconds before deactivating to standby “”.

TIP

- While LCS is active with the launch control system indicator “**LCS**” on, the LCS setting level cannot be changed and the “Settings”, “TRACK Settings”, and “Theme” items are grayed out in the menu system.
- If LCS is set to OFF, the “MODE” switch cannot be used to activate LCS.

Cruise control system

EAU5423

This model is equipped with a cruise control system designed to maintain a set cruising speed.

The cruise control system operates only when riding in 3rd gear or higher, at speeds between about 50 km/h (31 mi/h) and 180 km/h (110 mi/h).

EWA22860

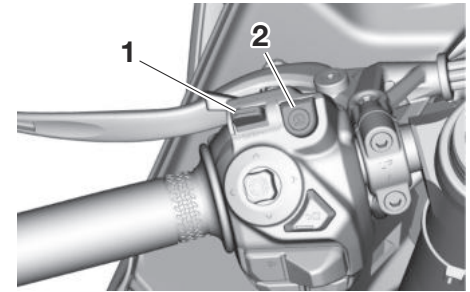

WARNING

- **Improper use of the cruise control system may result in loss of control, which could lead to an accident. Do not activate the cruise control system in heavy traffic, poor weather conditions, or among winding, slippery, hilly, rough or gravel roads.**
- **When traveling uphill or downhill, the cruise control system may not be able to maintain the set cruising speed.**
- **To prevent accidentally activating the cruise control system, turn it off when not in use. Make sure that the cruise control system indicator “” is off.**



1. Cruise control/YVSL setting switch “RES/+”/“SET/-”
2. Cruise control/YVSL button “”

Activating the cruise control system

1. Press the cruise control/YVSL button “” to turn on the system. The cruise control indicator “” and the set speed indicator “” will come on to indicate that the system is on standby.
2. Press the “SET/-” side of the cruise control/YVSL setting switch to activate the cruise control system. The vehicle’s current speed will become the set cruising speed and displayed green in the set speed indicator “**100**”_{km/h}. The cruise

Special features

control indicator “” will also turn green.

TIP

If the cruise control indicator “” comes on in amber, have a Yamaha dealer inspect the vehicle.

Adjusting the set cruising speed

While the cruise control system is active, press the “RES/+” side of the cruise control/YVSL setting switch to increase the set cruising speed or the “SET/-” side to decrease the set speed. Both the vehicle speed and the speed shown in the set speed indicator “100”
km/h will change accordingly.

TIP

Pressing the setting switch once will change the set speed in increments of 1 km/h (1 mi/h). Hold down the “RES/+” or “SET/-” side of the cruise control/YVSL setting switch to increase or decrease the speed by increments of 10 km/h (10 mi/h) until the switch is released.

You can also manually increase your traveling speed using the throttle. After

you have accelerated, you can set a new cruising speed by pressing the “SET/-” side of the cruise control/YVSL setting switch. If you do not set a new cruising speed, when you return the throttle grip, the vehicle will decelerate to the previously set cruising speed.

Deactivating the cruise control system

Perform any of the following actions to deactivate the cruise control system and place it on standby. When the system enters standby, both the cruise control indicator “” and the set speed indicator “100”
km/h will lose green status.

- Turn the throttle grip past the fully closed position in the deceleration direction.

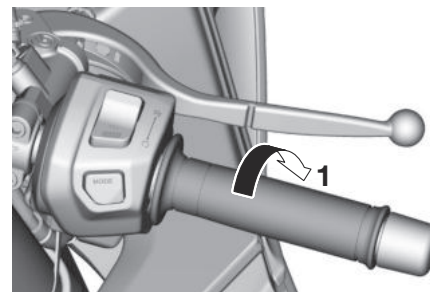

1. Deceleration direction

- Apply the front or rear brake.
- Disengage the clutch.
- Shift gears.

TIP

Traveling speed decreases as soon as the cruise control system is deactivated; unless the throttle grip is turned.

Using the resume function



Press the “RES/+” side of the cruise control/YVSL setting switch to reactivate the cruise control system from standby. The traveling speed will return to the previous set cruising speed. Both the cruise control indicator “” and the set speed indicator “100”
km/h will turn green.

WARNING

EWA16351

It is dangerous to use the resume function when the previously set cruising speed is too high for current conditions.

Turning off the cruise control system

At any time, press the cruise control/YVSL button “” to turn off the cruise control system completely. Both the cruise control indicator “” and the set speed indicator “” will go off.



TIP



Whenever the cruise control system or the vehicle power is turned off, the previously set cruising speed is erased. You will not be able to use the resume function until a new cruising speed has been set.

Automatic deactivation of the cruise control system

The cruise control system is electronically controlled and linked with other control systems. The cruise control

system will automatically deactivate under the following conditions:

- The cruise control system is not able to maintain the set cruising speed (such as when going up a steep hill).
- Wheel slip or wheel spin is detected. (If the traction control system is on, traction control will engage.)
- Engine operation switch “/” is set to “”.
- Engine is stopped.
- Side stand is lowered.
- Traction control system is turned off.

If the cruise control system turns off under the above conditions, the cruise control indicator “” and the set speed indicator “” will flash for 4 seconds before turning off.

To use the cruise control system again, press the cruise control/YVSL button “” to turn on the system.

TIP

When traveling uphill or downhill, the cruise control system may, in some cases, fail to maintain the set cruising speed.

- When the vehicle is traveling uphill, the actual traveling speed may become lower than the set cruising speed. If this occurs, accelerate to the desired traveling speed using the throttle.
- When the vehicle is traveling downhill, the actual traveling speed may become higher than the set cruising speed. If this occurs, the cruise control/YVSL setting switch cannot be used to adjust the set cruising speed. To reduce the traveling speed, apply the brakes. When the brakes are applied, the cruise control system will become deactivated.

Special features

Yamaha variable speed limiter (YVSL)

EUA44793

This model is equipped with the Yamaha variable speed limiter (YVSL) which limits the vehicle to a maximum speed set by the rider.

The YVSL can be set to any speed limit between 50 km/h (31 mi/h) and 180 km/h (110 mi/h). When the set speed limit is reached, the engine output is restricted to keep the vehicle from exceeding set speed limit without throttle control.

EWA22900

WARNING

- **Improper use of the YVSL system may result in loss of control, which could lead to an accident. Do not activate the YVSL system in heavy traffic, poor weather conditions, or among winding, slippery, hilly, rough or gravel roads.**
- **The YVSL system may not be able to maintain the set speed limit when traveling uphill, downhill, or under sudden acceleration.**

- **Confirm whether the YVSL system is ON/OFF before use.**
- **To prevent accidentally activating the YVSL system, turn it off when not in use. Make sure that the YVSL display is off.**



1. YVSL indicator
2. Set speed indicator

TIP

In some cases, the YVSL system may not be able to maintain the set speed limit when the vehicle is traveling downhill, under sudden acceleration, or immediately following a gear shift.







- If the vehicle exceeds the set speed limit by 5 km/h (3 mi/h) or more for more than 3 seconds, the YVSL indicator “” and the set

speed indicator “” will flash until the vehicle speed decreases to within the limit.

- If the vehicle traveling speed becomes higher than the set speed limit, apply the brakes.



When the YVSL disengages, engine output is gradually derestricted to ensure a smooth transition to full rider control of the throttle.

Activating and setting the YVSL

1. Press the cruise control/YVSL button “” located on the left handlebar. The cruise control indicator “” will come on in black/white.
2. Press the cruise control/YVSL button “” a second time to switch to YVSL standby mode. The YVSL indicator “” and the set speed indicator “” will come on in black/white.
3. Push the “SET-” side of the cruise control/YVSL setting switch to activate the YVSL. The YVSL indicator “” will come on and the

speed limit will be set to your current traveling speed which will be shown on the set speed indicator.

TIP

- Pressing the cruise control/YVSL button “” while the cruise control system is active and the cruise control indicator “” is on will also switch to the YVSL standby mode.
- The cruise control system and the YVSL system cannot both be active at the same time.

Adjusting the speed limit

While the YVSL is activated, push the “RES+” side of the cruise control/YVSL setting switch to increase the set speed limit or the “SET-” side to decrease the set speed limit.



TIP



Pushing the cruise control/YVSL setting switch once will change the set speed in increments of approximately 1 km/h (1 mi/h). Holding the setting switch will change the set speed in increments of 10 km/h (10 mi/h).

Deactivating the YVSL

When the YVSL is disengaged, engine output is gradually derestricted to ensure a smooth transition to full rider control of the throttle.

Press the cruise control/YVSL button “” located on the left handlebar.

YVSL system will deactivate and return to standby status, the YVSL indicator “” and set speed indicator “” will come on.

Press the cruise control/YVSL button “” again, and the YVSL system will shut off and the YVSL indicator “” and set speed indicator “” will both go off.

Using the resume function

Push the “RES+” side of the cruise control/YVSL setting switch to reactivate the YVSL when in standby mode. The speed limit will return to the previously set speed limit.

EWA21210



It is dangerous to use the resume function when the previously set

speed limit is too low for current conditions.

TIP

Pressing the cruise control/YVSL button “” while the YVSL system is in standby mode will turn the system off completely and erase the previously set speed limit.

You will not be able to use the resume function until a new speed limit has been set.

Special features

4

ESS (emergency stop signaling) system

EAU1773

When sudden deceleration occurs this system automatically activates to cause all turn signal lights to flash rapidly.

This provides additional warning to surrounding vehicles that your vehicle is decelerating rapidly.

The ESS system then deactivates under the following conditions:

- When the brakes are released.
- When sudden deceleration is no longer detected.

EWA22680



WARNING

The ESS system is not a collision prevention system. Avoid unnecessary hard braking and prioritize safe driving.

TIP

- The ESS system only activates when it detects sudden braking while the vehicle is traveling at speeds of 50 km/h (31 mi/h) or higher.

- ESS does not activate when the hazard lights are already activated.
 - If the ESS is activated while one of the turn signal lights is already flashing, the ESS takes priority, causing all turn signals to flash rapidly.
 - ESS does not operate when the ABS indicator light is on.
-

Smart features: Introduction

EAUJA5064
EWA23140

WARNING

- **Failure to pay attention while riding could result in death or serious injury. Always concentrate on riding by keeping your eyes and mind on the road.**
- **Stop the vehicle before making any settings changes or operating your smartphone.**
- **Changing settings while riding can distract the operator and increase the risk of an accident.**
- **Never take your hands off the handlebars while riding.**
- **Keep volume levels low enough to maintain awareness of your surroundings and ensure safety.**

This vehicle is equipped with an extensive suite of smart features utilizing your smartphone, connected to the vehicle through a communication control unit (CCU) and the Yamaha Motorcycle Connect app on your phone.

- GPS navigation (requires Garmin StreetCross) (page 5-5)

- Telephone (page 5-7)
- Audio player (page 6-38)
- Smartphone notifications (page 6-25)
- Weather information (page 6-25)
- Clock automatic update (page 6-35)
- Language settings

TIP

- Some features may not be available depending on your smartphone. Some music and SNS applications may not function properly in combination with other applications.
- The CCU takes approximately 10 seconds to initiate its Bluetooth function after the vehicle power is turned on. Related functions will be grayed out in the menu system during this time.

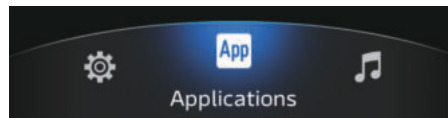

Smart features are accessed via the menu system on the main display (page 6-21). The menu system and all related features are controlled using the joystick / “✓” and the home button “↵” (page 6-5).

First, please read how to operate the basic menu controls in the next section, and then an initial setup and connection of a smartphone must be completed.

Menu system controls

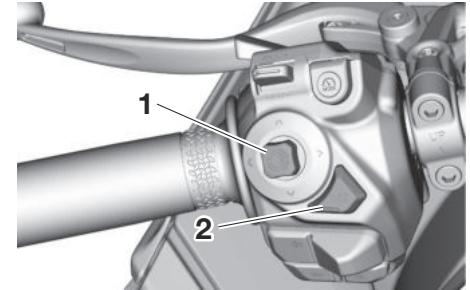

1. Joystick “✓”
2. Home button “↵”

This manual uses the following terms to describe the usage of the menu controls:



Smartphone Connectivity System

Short press	Briefly press the joystick or button
Long press	Press the joystick or button for 1 second

To open the pop-up menu from the main display:

Short press the home button “”

5 Menu system operation:

- Operate the joystick left-right-up-down to highlight and adjust menu items.
- Short press “” to select an item.
- Short press the home button “” to cancel/return to previous.
- Long press the home button “” to close the menu system.

TIP

When the navigation system is not connected, the navigation home display cannot be cycled to using the home button “”.

Yamaha Motorcycle Connect app



Yamaha Motorcycle Connect is a free app which is needed to complete the connection between the CCU and your smartphone. The app can be searched by name and downloaded from your smartphone application store.

TIP

- Use of Yamaha Motorcycle Connect is subject to your agreement to the Yamaha Motorcycle Connect terms of use.
- The Yamaha Motorcycle Connect app may not function on all smartphones or OS (operating system) versions.
- Navigation and other features require GPS access permissions to

be set as “Always allow” on your smartphone.

- Every smartphone operates differently; refer to your individual device instructions regarding connectivity, Bluetooth discovery, app permissions, and other settings.

Y-TRAC Rev app



Yamaha Y-TRAC Rev is a smartphone application developed to complement your Yamaha motorcycle. It provides tools for lap time management, Virtual Pit Board editing, monitoring vehicle performance, managing maintenance, and settings to enhance your riding experience.

The app can be downloaded from an app store.

Initial setup

This section describes the basic setup procedures to connect your smartphone to the CCU and start using smart features.

1. Download/install the Yamaha Motorcycle Connect app on your smartphone via an application store. Complete the installation and pair/connect it to the CCU via Bluetooth.



2. To use the navigation system, download/install the Garmin StreetCross app. Complete the installation and pair/connect it to the CCU via Bluetooth.



3. To use the audio/phone/navigation system route guidance, pair/connect a Bluetooth headset to your smartphone. (See page 5-6.)

Yamaha Motorcycle Connect pairing

ECAN0150

NOTICE

The Bluetooth connection may not work in the following situations.

- In a location exposed to strong radio waves or other electromagnetic noise.
- At facilities nearby that are emitting strong radio waves (TV or radio towers, power plants,

Smartphone Connectivity System

broadcasting stations, airports, etc.).

1. Download and install the Yamaha Motorcycle Connect app on your smartphone.
2. Short press the home button “ Applications” → “Connectivity Settings” → “Connection” → “Bluetooth”.

5

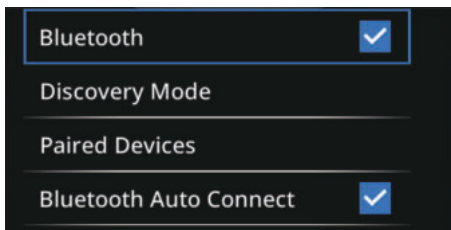

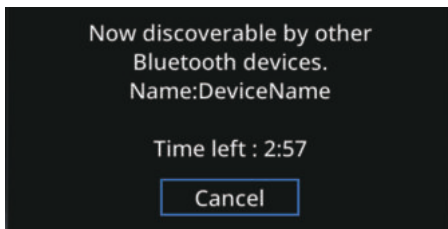

3. Make sure there is a blue checkmark next to “Bluetooth” and select “Discovery Mode”.



4. Open the Yamaha Motorcycle Connect app and navigate to the pairing display. Follow the instructions on the app to detect the CCU and pair/connect with it.

TIP

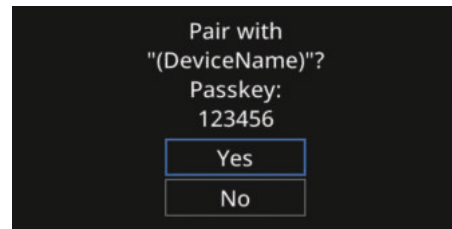
After making the CCU discoverable, a pairing must be completed within 3 minutes or the process will fail. If a failure occurs, select “Discovery Mode” again to retry.

5. A request for Bluetooth pairing will appear with a passkey matching the one displayed on the smartphone. Operate the joystick to highlight “Yes” and then short press “A screenshot of a dialog box for pairing a device. It asks 'Pair with "(DeviceName)"?' and shows a 'Passkey: 123456'. There are two buttons: 'Yes' and 'No'.

6. Accept the pairing request on your smartphone.

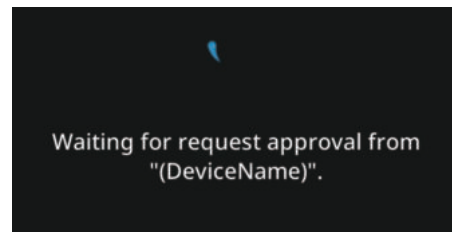

TIP

- After the passkey appears, the pairing must be confirmed within 30 seconds or it will time out. If a failure occurs, select “Discovery Mode” again to retry.

Smartphone Connectivity System

- When connected, the Yamaha Motorcycle Connect indicator “App” will appear on the top of the main display and also next to the connected smartphone device name in the “Paired Devices” list. (See page 6-26.)

TIP

- A request will appear on your smartphone to share contact information with the vehicle. If you decline to upload the data to the CCU and/or allow access to notifications, you can do so later in your smartphone’s settings.
- If a Bluetooth pairing record is deleted from the smartphone, then the corresponding pairing record must be deleted from the “Paired Devices” list in order to pair again successfully.
- If a Bluetooth pairing record is deleted from the “Paired Devices” list, then the corresponding pairing record must be deleted from the smartphone in order to pair again successfully.

- The first time the vehicle is paired with the Yamaha Motorcycle Connect app, the menu system language will change to match the language selected in the app. When first installed, the app adopts the system language of the smartphone. If the language is not supported by the CCU, then English will be automatically selected.
- Once paired, the Yamaha Motorcycle Connect app will open automatically when a Bluetooth connection is established and will connect to the CCU automatically (This functionality varies by smartphone and/or OS versions. Refer to the Yamaha Motorcycle Connect app for more details).

Navigation system: Garmin StreetCross

EWA21401

WARNING

- **Always stop the vehicle before operating the navigation system.**

- **Always concentrate on riding by keeping your eyes and mind on the road.**



This vehicle is equipped with a navigation system which provides visual and audio route guidance. To use the navigation system, you must first download the Garmin StreetCross app from an application store on a smartphone and then register for its service.

See page 6-20 for more information about operating the navigation system.

TIP

- Use of the Garmin StreetCross app is subject to your agreement to the Garmin StreetCross terms of use.

Smartphone Connectivity System

5

- Yamaha shall not be liable for any damages resulting from the use of the Garmin StreetCross app.
- The smartphone must remain unlocked and the Garmin StreetCross app must be kept in the foreground in order to ensure the smartphone does not sleep (lock). If another app's function moves the Garmin StreetCross app to the background (phone call, alarm, etc.) the smartphone may sleep (lock) and the navigation may stop.
- The Garmin StreetCross app's GPS access permissions must be set to "Always allow" on your smartphone's settings.
- The Garmin StreetCross app may not work on all smartphones or OS (operating system) versions.
- While route guidance is active, the weather information at the destination will be displayed. If the destination is more than 1 hour away, the weather information will be from a location 1 hour away on route to the destination.

Garmin StreetCross pairing

ECAN0150

NOTICE

The Bluetooth connection may not work in the following situations.

- **In a location exposed to strong radio waves or other electro-magnetic noise.**
- **At facilities nearby that are emitting strong radio waves (TV or radio towers, power plants, broadcasting stations, airports, etc.).**

1. Download and install the Garmin StreetCross app on your smartphone.
2. Open the Garmin StreetCross app and tap "📶" to open the connection menu and follow the instructions in the app to pair/connect to the CCU.

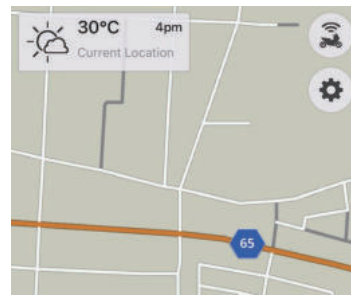

TIP

When connected, the navigation connection indicator "📶" will appear on the top of the main display and the Bluetooth symbol "📶" will appear next to the connected smartphone device name in the "Paired Devices" list. (See page 6-26.)

Bluetooth headset pairing

Follow your headset's manufacturer instructions to pair/connect to your smartphone. When the headset connection is detected by the Yamaha Motorcycle Connect app, the headset indicator "📶" will appear on the top of the main display.

EAUA1890

TIP

When using the headset voice function, the Bluetooth connection between the smartphone and the CCU may become unstable. See the Yamaha Motorcycle Connect app for more details.

Telephone

This vehicle is equipped with a telephone function that requires both a smartphone and a Bluetooth headset. The smartphone must be paired and connected to both the CCU and a Bluetooth headset (page 5-3).

Receiving phone calls:

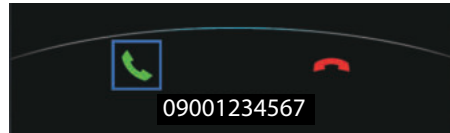

When a phone call is received to a connected smartphone, the ringtone will play through the connected headset and a telephone function will appear at the bottom of the display. Highlight the green phone icon and short press “✓” to answer the call. The active phone call indicator icon “☎” will appear for the duration of the call.

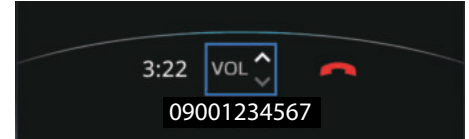

Highlight the volume icon and operate the joystick up-down to adjust the call volume. Highlight the end call icon and short press “✓” to hang up the call.

TIP

- For some smartphone models, the call volume cannot be adjusted using the handlebar switches. In this case, the volume adjustment will be grayed out on the active call display.
- When a phone call is active and a second incoming call is accepted, the first call will be put on-hold until the second call is ended.
- For some smartphones, when a call is active and a second incoming call is rejected, the displayed caller ID might change to the second caller ID.
- For some smartphones, rejecting a call with the joystick / “✓” will not function correctly. The end call

Smartphone Connectivity System

icon may be grayed out or using the end call icon will accept the call instead. In this case, operate the smartphone directly to end the call.

- **Keep volume levels low enough to maintain awareness of your surroundings and ensure safety.**

Making phone calls:

To make a phone call, you must start the phone call directly on your smartphone. Once active, the active call display will be accessible under “Phone” in the menu system (page 6-38) and the active call indicator will appear at the top of the main display (page 6-16). The call audio will play through the connected Bluetooth headset.

EWA21420

⚠ WARNING

- **Do not use your smartphone while the vehicle is in motion.**
- **Never take your hands off the handlebars while riding.**
- **Always concentrate on riding by keeping your eyes and mind on the road.**

EAU99213

Connection troubleshooting

If a connection error occurs between the smartphone, Yamaha Motorcycle Connect app, Garmin StreetCross app and/or CCU, the following screen is displayed.

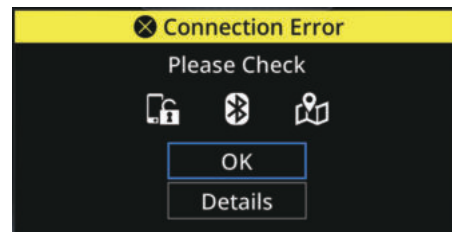

Select “Details” and check the connection as instructed on the screen.

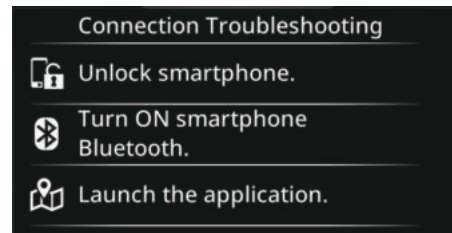

If the error persists, try the following:

1. Turn OFF the vehicle power. After 20 seconds, turn ON the vehicle power again.
2. Turn OFF the smartphone's Bluetooth. Then turn it ON again.
3. Delete Bluetooth pairing information from both smartphone and vehicle.
4. Reboot the Yamaha Motorcycle Connect app and Garmin Street-Cross app.

Instrument and control functions

Immobilizer system

EAU1097C

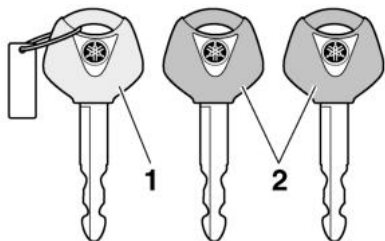

1. Code re-registering key (red bow)
2. Standard keys (black bow)

This vehicle is equipped with an immobilizer system to help prevent theft by re-registering codes in the standard keys. This system consists of the following:

- a code re-registering key
- two standard keys
- a transponder (in each key)
- an immobilizer unit (on the vehicle)
- an ECU (on the vehicle)
- a system indicator light (page 6-6)

About the keys

The code re-registering key is used to register codes in each standard key. Store the code re-registering key in a safe place. Use a standard key for daily operation.

When key replacement or re-registering is necessary, bring the vehicle and the code re-registering key along with any remaining standard keys to a Yamaha dealer to have them re-registered.

TIP

- Keep the standard keys as well as keys of other immobilizer systems away from the code re-registering key.
- Keep other immobilizer system keys away from the main switch as they may cause signal interference.

ECA11823

NOTICE

DO NOT LOSE THE CODE RE-REGISTERING KEY! CONTACT YOUR DEALER IMMEDIATELY IF IT IS LOST! If the code re-registering key is lost, the existing standard keys

can still be used to start the vehicle. However, registering a new standard key is impossible. If all keys have been lost or damaged, the entire immobilizer system must be replaced. Therefore, handle the keys carefully.

- Do not submerge in water.
- Do not expose to high temperatures.
- Do not place near magnets.
- Do not place near items that transmit electrical signals.
- Do not handle roughly.
- Do not grind or alter.
- Do not disassemble.
- Do not put two keys of any immobilizer system on the same key ring.

Main switch/steering lock

EAU10475

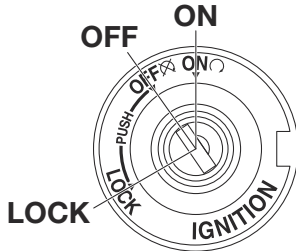

The main switch/steering lock controls the ignition and lighting systems, and is used to lock the steering. The various positions are described below.

TIP

Be sure to use the standard key (black bow) for regular use of the vehicle. To minimize the risk of losing the code re-registering key (red bow), keep it in a safe place and only use it for code re-registering.

EAU84035

ON

All electrical circuits are supplied with power and the vehicle lights are turned

on. The engine can be started. The key cannot be removed.

TIP

- The headlight(s) will turn on when the engine is started.
- To prevent battery drain, do not leave the key in the “ON” position without the engine running.

OFF

All electrical systems are off. The key can be removed.

EAU10664

⚠ WARNING

Never turn the key to “OFF” or “LOCK” while the vehicle is moving. Otherwise the electrical systems will be switched off, which may result in loss of control or an accident.

EWA10062

LOCK

The steering is locked and all electrical systems are off. The key can be removed.

EAU73803

To lock the steering

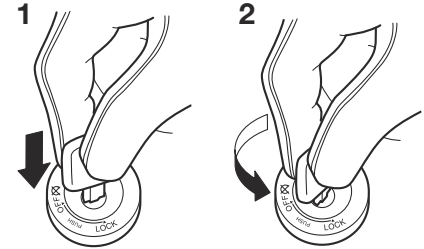

1. Push.
2. Turn.

1. Turn the handlebars all the way to the left.
2. With the key in the “OFF” position, push the key in and turn it to “LOCK”.
3. Remove the key.

TIP

If the steering will not lock, try turning the handlebars back to the right slightly.

Instrument and control functions

To unlock the steering

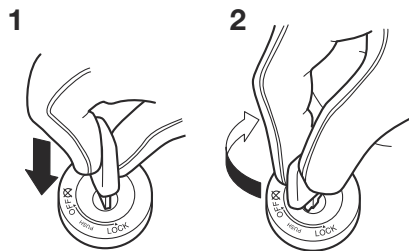

6

1. Push.
2. Turn.

Push the key in and turn it to “OFF”.

Handlebar switches

EAU6605B

Left

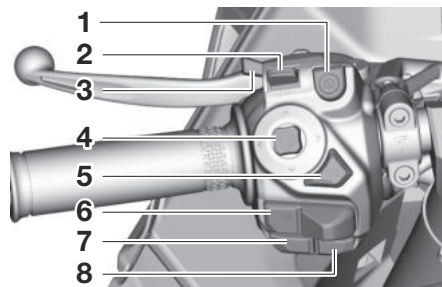

1. Cruise control/YVSL button “MODE”
2. Cruise control/YVSL setting switch “RES/+”/“SET/-”
3. Dimmer/Pass switch “ \equiv O/ \equiv O”
4. Joystick “✓”
5. Home button “ \rightarrow ”
6. Turn signal switch “ \leftarrow / \rightarrow ”
7. Horn switch “ H ”
8. Hazard switch “ Δ ”

Right

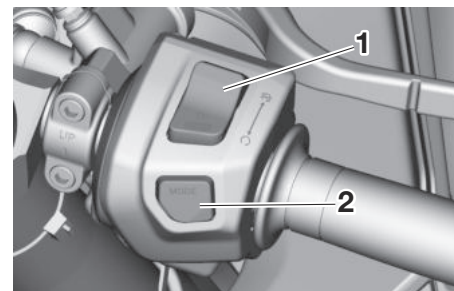

1. Engine operation switch “ \otimes / \circ / \otimes ”
2. YRC mode button “MODE”

Dimmer/Pass switch “ \equiv O/ \equiv O”

EAU2611

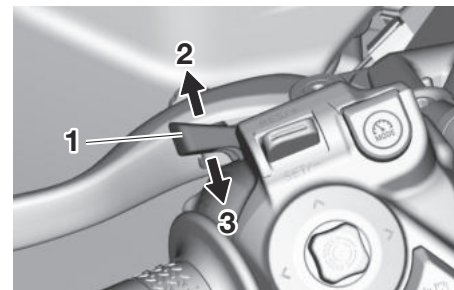

1. Dimmer/Pass switch “ \equiv O/ \equiv O”
2. Direction A
3. Direction B

Push this switch outward (direction A) to turn the high beam on. Push this switch inward (direction B) to return to low beam.

While the headlights are set to low beam, push the switch inwards (direction B) to momentarily flash the high beam.

In TRACK theme: This switch is additionally used to operate the lap timer. While the headlights are on low beam, and the switch is pushed inwards (direction B), the lap timer will start/count a lap. In this case the high beam will not flash.

EUAJ1741

Turn signal switch “/”

This switch controls the turn signal lights. This is a 2-stage switch, meaning that pressing it soft or hard has a different effect.

Soft press: Lightly press the switch in the direction you wish to signal, until a soft click is felt. The corresponding turn signal light will flash three times and stop.

Hard press: Firmly press the switch in the direction you wish to signal, until a

stronger click is felt. The corresponding turn signal light will flash continuously until all of the following conditions occur:

- The vehicle travels approx. 150 m (490 ft).
- More than 15 seconds has elapsed.
- The vehicle speed is more than 5 km/h (3 mi/h).

ECA28520

NOTICE

Depending on the conditions, the turn signal may not automatically turned off within the specified time or distance travelled.

To cancel a turn signal manually, press the switch a second time in the same direction.



EUA66030

Horn switch “”

Press this switch to sound the horn.

EUAJ9170

Engine operation switch “/”

To crank the engine with the starter, set this switch to run “”, and then push the switch down towards start “”.

See page 8-2 for starting instructions prior to starting the engine.

Set this switch to stop “” to stop the engine in case of an emergency, such as when the vehicle overturns.

TIP

This manual sometimes refers to the three positions of this switch as individual switches.

“” : Stop switch

“” : Run switch

“” : Start switch

EAU91671

Hazard switch “”

Use this switch to turn on the hazard lights (simultaneous flashing of all turn signal lights). The hazard lights are used in case of an emergency or to warn other drivers when your vehicle is stopped where it might be a traffic hazard.

The hazard lights can be turned on or off only when the main switch is in the “ON” position. You can turn the main switch to the “OFF” or “LOCK” position, and the hazard lights will continue to flash. To turn off the hazard lights,

Instrument and control functions

turn the main switch to the “ON” position and operate the hazard switch again.

ECA10062

NOTICE

Do not use the hazard lights for an extended length of time with the engine not running, otherwise the battery may discharge.

EAU94151

Cruise control/YVSL switches

See page 4-6 for an explanation of the cruise control system.

See page 4-9 for an explanation of the YVSL.

EAU1941

YRC mode button “MODE”

Short press this button to cycle the YRC mode presets.

Theme1-3: Long press this button to open a YRC mode pop-up at the bottom of the display.

See page 6-12 and 6-30 for more information.

EAU1923

Joystick “✓” and home button “↶”

These are used to control the display/menu system.

See pages 5-1, 6-11 and 6-21 for more detailed explanations of their function.

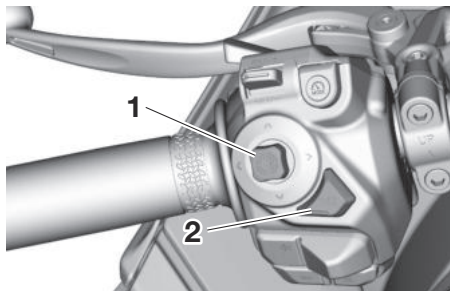

1. Joystick “✓”
2. Home button “↶”

EAU5932

Indicator lights and warning lights

ECA29090

NOTICE

If an indicator or warning is signaling a problem or abnormal condition, then stop all vehicle operation immediately. Have a Yamaha dealer inspect the vehicle.

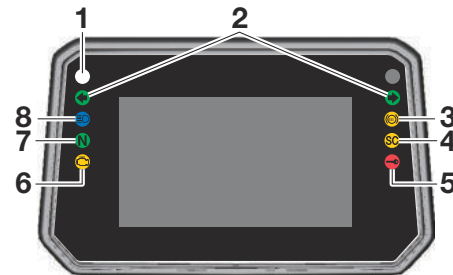

1. Shift indicator light “○”
2. Turn signal indicator lights “←” and “→”
3. ABS warning light “☺”
4. Stability control indicator light “SC”
5. Immobilizer system indicator light “ⓧ”
6. Engine trouble warning light “⚠”
7. Neutral indicator light “N”
8. High beam indicator light “⚡”

Turn signal indicator lights “” and “”

EAU1910

Each indicator light will flash when its corresponding turn signal lights are flashing.

Neutral indicator light “”

EAU88300

This indicator light comes on when the transmission is in the neutral position.

High beam indicator light “”

EAU88310

This indicator light comes on when the high beam of the headlight is switched on.

Engine trouble warning light “”

EAU94721

This warning light comes on if a problem is detected in the engine or other vehicle control systems. If this occurs, have a Yamaha dealer check the on-board diagnostic system.

TIP

When the vehicle is turned on, this light should come on for a few seconds and

then go off. Otherwise, have a Yamaha dealer check the vehicle.

ABS warning light “”

EAU6140

In normal operation, the ABS warning light comes on when the vehicle is turned on, and goes off after traveling at a speed of 10 km/h (6 mi/h) or higher.

TIP

If the warning light does not work as described above, or if the warning light comes on while riding, the ABS may not work correctly. Have a Yamaha dealer check the vehicle as soon as possible.



EAU22910

If the ABS warning light does not turn off after reaching 10 km/h (6 mi/h), or if the warning light comes on while riding:

- Use extra caution to avoid possible wheel lock during emergency braking.
- Have a Yamaha dealer check the vehicle as soon as possible.

Shift indicator light “”

EAU9711

This indicator light comes on when it is time to shift to the next higher gear. The engine speeds at which it comes on or goes off and other settings can be adjusted in the menu system. (See page 6-37.)

TIP

- The shift indicator light does not operate when the vehicle is in neutral or 6th gear.
- When the vehicle is turned on, this light should come on for a few seconds and then go off. If the light does not come on, or if the light remains on, have a Yamaha dealer check the vehicle.

Immobilizer system indicator light

EAU88350

“”

When the main switch is turned off and 30 seconds have passed, the indicator light will flash steadily to indicate the immobilizer system is enabled. After 24 hours have passed, the indicator light will stop flashing, however the immobilizer system is still enabled.

Instrument and control functions

TIP

When the vehicle is turned on, this light should come on for a few seconds and then go off. If the light does not come on, or if the light remains on, have a Yamaha dealer check the vehicle.

Transponder interference

If the immobilizer system indicator light flashes in the pattern, slowly 5 times then quickly 2 times, this could be caused by transponder interference. If this occurs, try the following.

1. Make sure there are no other immobilizer keys close to the main switch.
2. Use the code re-registering key to start the engine.
3. If the engine starts, turn it off, and try starting the engine with the standard keys.
4. If one or both of the standard keys do not start the engine, take the vehicle and all 3 keys to a Yamaha dealer to have the standard keys re-registered.

EUA1782

Stability control indicator light “SC”

When TCS (traction control system) is set to off, this indicator will come on.

This indicator light flashes when the TCS (traction control system), SCS (slide control system), LIF (lift control system), or BSR (back slip regulator) engage while riding.

TIP

When the vehicle is turned on, this light should come on for a few seconds and then go off. If the light does not come on, or if the light remains on, have a Yamaha dealer check the vehicle.

ECA28540

NOTICE

When turning the main switch on, avoid any movement or vibration of the vehicle as it may interfere with the initialization of the IMU. If this occurs, the traction control system will not operate and the stability control indicator light “SC” will come on until the IMU can initialize.

Display

Theme1



Theme2

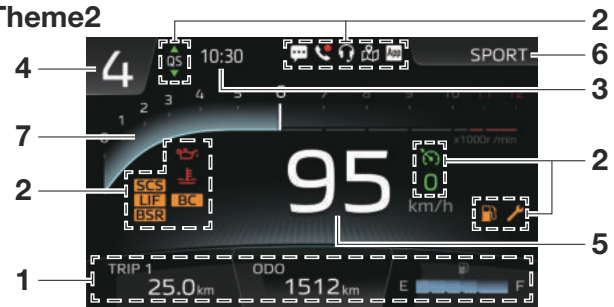

Theme3



Theme4



1. Vehicle information display
2. Indicator icons
3. Clock
4. Transmission gear display
5. Speedometer

6. YRC mode display
7. Tachometer

Instrument and control functions

TRACK

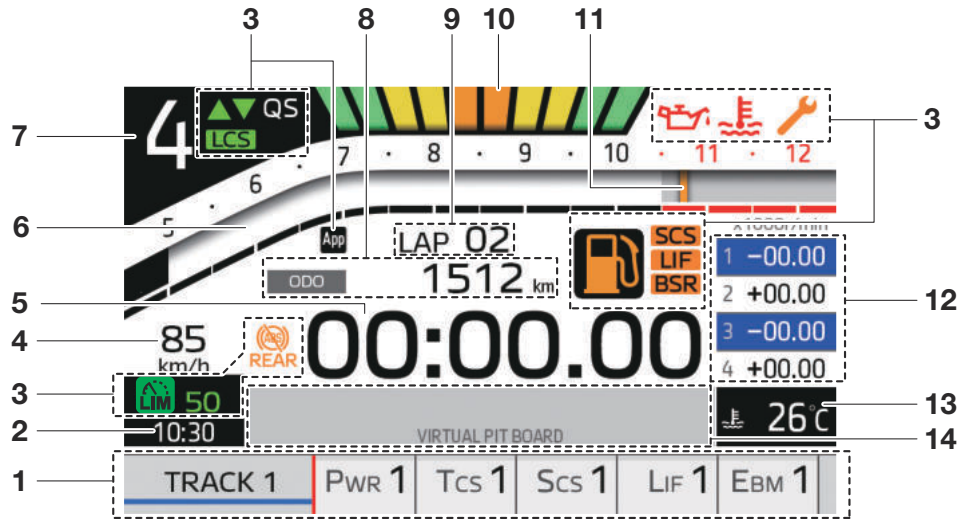

1. YRC mode display
2. Clock
3. Indicator icons
4. Speedometer
5. Lap time display
6. Tachometer
7. Transmission gear display
8. Vehicle information display

9. Lap counter
10. Shift indicator
11. Revolution peak hold indicator
12. Sector time display
13. Coolant temperature display
14. Virtual pit board

Instrument and control functions

Minimized display view (while menu system/navigation are open)

When the menu system or the navigation function are open, the information on the main display is relocated as shown.

Theme1, 2, 3



Theme4, TRACK

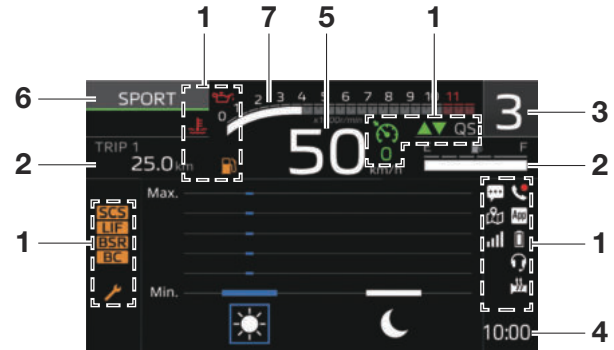

1. Indicator icons
2. Vehicle information display
3. Transmission gear display
4. Clock
5. Speedometer
6. YRC mode display
7. Tachometer

Instrument and control functions

EAU45207

TIP

- The brightness level of the display screen can be adjusted in the menu system. (See page 6-36.)
- If the display becomes too hot, the display screen brightness levels will automatically reduce to avoid damage.
- This model uses a thin-film-transistor liquid-crystal display (TFT LCD) for good contrast and readability in various lighting conditions. However, due to the nature of this technology, it is normal for a small number of pixels to be inactive.
- In TRACK theme, the audio player, telephone and headset related functions are not controllable from the vehicle.
- The display units can be switched between kilometers-miles and Celsius-Fahrenheit. (See page 6-36.)
- The navigation system display units can be changed separately using the Garmin StreetCross app.

Display system controls

The display user interface is controlled with the joystick / “✓” and the home button “”. (See page 6-5.) Each control has various functions for different situations, see the following list for details.

Operate the joystick left-right-up-down:

Main display active: highlights and adjusts items in the vehicle information display, and also the YRC mode display (Theme4, TRACK).

Navigation active: up-down zoom the map view in-out.

Turn-by-turn pop-up active: left-right adjust the displayed information.

Menu system active: highlight and adjusts various menu items.

Short press “✓”:

Main display active: highlight and select items in the vehicle information display, and also the YRC mode display (Theme4).

Navigation active: directly open the “Navigation” menu display.

Menu system active: select highlighted menu items.

Long press “✓”:

Highlighted vehicle information display item flashing: reset the item.

Smartphone connected with music app: play/pause music (except TRACK).

Short press the home button “”:

Main display/navigation active: open the first pop-up layer of the menu system.

Menu system active: cancel/return to previous.

Long press the home button “”:

Main display active: switch to navigation display (except TRACK).

Navigation active: switch to main display.

Menu system active: exit to the previously open main display/navigation display.

Clock

The clock uses a 12-hour time system. The clock is updated automatically

from connected smartphones or can also be manually set in “⚙️ Settings” → “Clock”. (See page 6-35.)

Speedometer

The speedometer shows the vehicle’s traveling speed.

Tachometer

The tachometer shows the engine speed, as measured by the rotational velocity of the crankshaft, in revolutions per minute (r/min).

ECA10032

NOTICE

Do not operate the engine in the tachometer red zone.

Red zone: 10500 r/min and above

Transmission gear display

This display shows which gear the transmission is in. This vehicle has 6 gears and a neutral position. The neutral position is indicated by the neutral indicator light “N” and by the transmission gear display reading: “N”.

YRC mode display

This display indicates which YRC mode is currently selected: “SPORT”, “STREET”, “RAIN”, “CUSTOM 1” and “CUSTOM 2”.

Cycle through the YRC modes by using the YRC mode button “MODE” and also view/customize them in the menu system. (See page 6-30.)

TIP

- The names of “CUSTOM 1” and “CUSTOM 2” can also be customized via the Yamaha Motorcycle Connect app.
- In TRACK theme, the available YRC modes are “TRACK 1-4”.

In Theme4, TRACK:

In these themes, the YRC mode display is expanded to show the current “PWR”, “TCS”, “SCS”, “LIF”, and “EBM” settings for each YRC mode. In addition to using the YRC mode button “MODE”, you can move the joystick up-down to cycle between the vehicle information display and the YRC mode display. When highlighted, short press “✓” to select the YRC mode display.

Move the joystick left-right to cycle between the available items. Move the joystick up-down to cycle the highlighted YRC mode or change the setting for the highlighted item.

TIP

- In TRACK theme, simply operating the joystick will adjust the YRC mode display. You do not need to first highlight and select the YRC mode display.
- In TRACK theme, with a YRC item (except “PWR” and “EBM”) highlighted, long press “✓” to disable that item. While disabled, the item level will read “0”.

In Theme1-3:



Long press the YRC mode button “MODE” to open/close an expanded YRC mode pop-up at the bottom of the screen. While the pop-up is open, short

Instrument and control functions

press the YRC mode button “MODE” to cycle through the presets and use the joystick to adjust individual items.

TIP

- If the selected YRC mode is customizable, “PWR”, “TCS”, “SCS”, and “LIF” can be highlighted and adjusted using the joystick.
- “EBM” can be adjusted for any of the YRC modes.

6

For more information on YRC modes see page 4-1.

Vehicle information display

The vehicle information display contains 3 cells which can be set to display the following:

- Odometer “ODO”
- Two tripmeters “TRIP 1 / TRIP 2”
- Fuel reserve tripmeter “TRIP F”
- Instantaneous fuel consumption “INST FUEL”
- Average fuel consumption “AVG FUEL”
- Estimated fuel range “RANGE”
- Coolant temperature “COOLANT”
- Air temperature “AIR”
- Trip timer “TRIP TIME”

- Fuel Meter

In Theme1-3:

- Move the joystick left-right to cycle between the cells. Move the joystick up-down to cycle the display item for the highlighted cell. If a display item is flashing, long press “✓” to reset it.
- It can also be set in “Ⓜ Vehicle Info” in the menu system.

In Theme4:

Move the joystick up-down to cycle between the vehicle information display and the YRC mode display. When highlighted, short press “✓” to select the vehicle information display. Move the joystick left-right to cycle between the cells. Move the joystick up-down to cycle the display item for the highlighted cell. If a display item is flashing, long press “✓” to reset it.

In TRACK:

The vehicle information display contains 1 cell which can be set to display the following:

- Fastest lap time “FASTEST”

- Reference lap time “REFER.”
- Latest lap time “LATEST”
- Odometer “ODO”
- Average fuel consumption “AVG FUEL”
- Air temperature “AIR”

TIP

In TRACK theme, the fuel reserve tripmeter “TRIP F” is not visible unless triggered by low fuel status. Once activated, it takes the place of the current display item and then turns off upon refueling.

Navigate to “Ⓜ Vehicle Info” in the menu system to highlight the vehicle information display. Once highlighted, operate the joystick up-down to cycle the visible item.

If a display item is flashing, long press “✓” to reset it.

TIP

- Resettable items can also be individually viewed and reset by navigating to “⚙ Settings” → “Information / Reset” in the menu system. (See page 6-29.)

Instrument and control functions

- While on the navigation display, navigate to “ Vehicle Info” in the menu system to highlight the two cells.

Odometer “ODO”

The odometer shows the total distance traveled by the vehicle.

TIP

The odometer will lock at 999999 and cannot be reset.

Tripmeters “TRIP 1 / TRIP 2”

“TRIP 1” and “TRIP 2” show the distance traveled since they were last set to zero.

“TRIP 1” and “TRIP 2” will reset to 0 and begin counting again after 9999.9 has been reached.

Fuel reserve tripmeter “TRIP F”

When the fuel tank reserve level has been reached, “TRIP F” activates and begins recording distance traveled from that point. After refueling and traveling some distance, “TRIP F” will automatically deactivate and reset.

TIP

When “TRIP F” is inactive it will show as “--.-”.

Instantaneous fuel consumption “INST FUEL”

When using kilometers, the instantaneous fuel consumption display can be set to “km/L” or “L/100km”. (See page 6-36.)

When using miles, the instantaneous fuel consumption is displayed in “MPG”.

Average fuel consumption “AVG FUEL”

When using kilometers, the average fuel consumption display can be set to “km/L” or “L/100km”. (See page 6-36.)

When using miles, the average fuel consumption is displayed in “MPG”.

Estimated fuel range “RANGE”

The estimated distance that can be traveled under the current riding conditions with the remaining fuel.

Coolant temperature “COOLANT”

The coolant temperature is displayed from $-30\text{ }^{\circ}\text{C}$ ($-22\text{ }^{\circ}\text{F}$) to $130\text{ }^{\circ}\text{C}$ ($266\text{ }^{\circ}\text{F}$) in $1\text{ }^{\circ}\text{C}$ ($1\text{ }^{\circ}\text{F}$) increments.

TIP

- When using Celsius, the coolant temperature display will read “-30” when the vehicle coolant temperature is below $-30\text{ }^{\circ}\text{C}$.
- When using Fahrenheit, the coolant temperature display will read “-22” when the vehicle coolant temperature is below $-22\text{ }^{\circ}\text{F}$.
- If the vehicle coolant temperature is too high the coolant temperature display will read “Hi”.

Air temperature “AIR”

The air temperature is displayed from $-9\text{ }^{\circ}\text{C}$ ($15\text{ }^{\circ}\text{F}$) to $50\text{ }^{\circ}\text{C}$ ($122\text{ }^{\circ}\text{F}$) in $1\text{ }^{\circ}\text{C}$ ($1\text{ }^{\circ}\text{F}$) increments. The displayed temperature may differ from the actual ambient temperature due to the vehicle temperature and other factors.

Instrument and control functions

TIP

- “---” will be displayed if the detected temperature is lower than -9°C (15°F).
- “---” will be displayed if the detected temperature is higher than 50°C (122°F).

Trip timer “TRIP TIME”

Displays the engine running time.

Fuel Meter

The fuel meter indicates the amount of fuel in the fuel tank. The display segments of the fuel meter disappear from “F” (full) towards “E” (empty) as the fuel level decreases. When the last segment starts flashing, refuel as soon as possible.

ECAE0121

NOTICE

Do not let the vehicle run completely out of fuel. This may cause damage to the catalytic converter.

Fastest lap time “FASTEST”

Indicates the fastest lap time recorded since the lap timer was started. If no laps have been recorded, it will read 00:00.00.

Reference lap time “REFER.”

This item replaces the “FASTEST” item when the “Auto Lap Timer” function is activated. It shows a reference lap time which can be set using the Y-TRAC Rev app. With each complete lap, the item will briefly display “GAP” and a +/- time to indicate the time difference from the reference lap.

Latest lap time “LATEST”

Indicates the latest lap time recorded. If no laps have been recorded, it will read 00:00.00.

Cruise control/YVSL display



1. Cruise control indicator
2. Set speed indicator



1. YVSL indicator
2. Set speed indicator

Instrument and control functions

TIP

For more information about the cruise control and YVSL systems, see pages 4-6 and 4-9.

Cruise control indicator “”

This icon comes on if the cruise control system is on standby, turns green when the system is active, or amber if there is an error.

YVSL indicator “”

This icon comes on if the YVSL system is on standby, turns green when the system is active, or amber if there is an error.

Set speed indicator “”

This displays the set speed of the cruise control system or YVSL system.

 speed set, system on standby.

 speed set, system is active.

 speed not set.

Warning and indicator icons

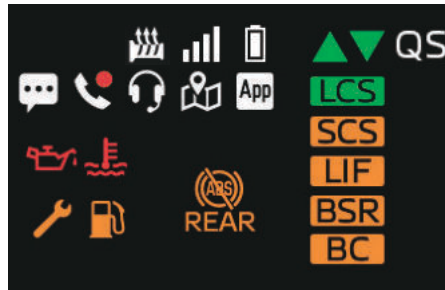

Low fuel indicator “”

This icon comes on when approximately 2.5 L (0.66 US gal, 0.55 Imp.gal) of fuel remains in the tank.

Coolant temperature warning “”

This icon appears when the coolant temperature is high. Stop the vehicle and turn off the engine. Allow the engine to cool.

ECA10022

NOTICE

Do not continue to operate the engine if it is overheating.

Oil pressure warning “”

This icon appears when the engine oil pressure is low. When the vehicle is first turned on, engine oil pressure has yet to build, so this indicator will come on and stay on until the engine has been started.

TIP

If a malfunction is detected, this icon will flash repeatedly.

ECA26410

NOTICE

Do not continue to operate the engine if the oil pressure is low.

Auxiliary system warning “”

This icon appears if a problem is detected in a system not related to the engine.

Quick shift indicator “QS”

This icon and accompanying arrow icons indicate the status of the quick shifter.

Respective arrow icon off: the quick shifter is disabled.

Instrument and control functions

▲ : the system is active for upshifts but cannot currently quickshift.

▼ : the system is active for downshifts but cannot currently quickshift.

▲ : quick upshift available.

▼ : quick downshift available.

TIP

- The upshift and downshift functions are independent and can be activated separately in the menu system. (See page 6-30.)
- For more information on the quick shifter see page 4-3.

Network connectivity indicator “” (except TRACK)

This icon indicates the connected smartphone’s network connection status.

Icon off: No smartphone connected.

 : A smartphone is connected but has no network connectivity.

 : A smartphone is connected and has network connectivity. The icon segments indicate the signal strength.

TIP

This icon may not operate with some smartphone models, even if the connected smartphone has network connectivity.

Smartphone battery level indicator “” (except TRACK)

This icon indicates the connected smartphone’s battery level.

Icon off: No smartphone connected.

 : The center bar moves up and down to indicate the battery level.

 : Smartphone is charging.

TIP

The battery level indicated by the icon may not always be consistent with the battery level displayed on the smartphone.

Headset indicator “” (except TRACK)

This icon comes on if a Bluetooth headset is connected to the smartphone.

TIP

For some smartphones, this icon may go off during phone calls.

Yamaha Motorcycle Connect app indicator “”

This icon comes on when the Yamaha Motorcycle Connect app is successfully connected to the vehicle.

 : The icon turns yellow when the connected smartphone becomes overheated.

TIP

Depending on the smartphone, the icon may remain yellow even after the smartphone is no longer overheating.

Navigation connection indicator “” (except TRACK)

This icon comes on when the Garmin StreetCross app is connected.

Telephone indicator “/” (except TRACK)

This icon comes on green when there is an active call and red when there is a recent missed call. The missed call icon will disappear when the recent contact list is opened at “ Applications” → “Phone” in the menu system.

Instrument and control functions

Notification indicator “” (except TRACK)

This icon comes on when the connected smartphone receives an SNS, E-mail or other notification. After that, the icon stays on until you turn the vehicle off. Check the notifications by navigating to “ Applications” → “Notification” in the menu system.

TIP

- This function works only when a smartphone is connected to the CCU via the Yamaha Motorcycle Connect app.
- Permission to access notifications must be granted to the Yamaha Motorcycle Connect app on your smartphone.

Grip warmer indicator “” (except TRACK) (if equipped)

The grip warmers can be used when the engine is running. There are 3 customizable temperature presets that can be customized between 10 different temperature levels. (See page 6-28.)

The icon displays the current temperature setting:

: Grip warmer off

: Low preset

: Medium preset

: High preset

ECA17932

NOTICE

- **Be sure to wear gloves when using the grip warmers.**
- **Do not use the grip warmers in warm weather.**
- **If the handlebar grip or throttle grip becomes worn or damaged, stop using the grip warmers and replace the grips.**

BC indicator “”

This icon comes on if “BC” (brake control system) is deactivated.

ECA28551

NOTICE

When turning the main switch on, avoid any movement or vibration of the vehicle as it may interfere with the initialization of the IMU. If this occurs, the brake control system will not operate and the BC indicator

“” will come on until the IMU can initialize.

SCS indicator “”

This icon comes on if “SCS” (slide control system) is deactivated.

LIF indicator “”

This icon comes on if the “LIF” (lift control system) is deactivated.

BSR indicator “”

This icon comes on if the “BSR” (back slip regulator) is deactivated.



REAR ABS OFF indicator “”

This icon comes on to indicate that “REAR ABS OFF” has been selected in the menu system and the rear wheel anti-lock braking system is disabled. (See page 6-35.)

TIP

When the rear wheel anti-lock braking system is disabled, the “BC” (brake control system) is also disabled. However, only the REAR ABS OFF indicator

Instrument and control functions

“” will be displayed, not the BC indicator “”.

Coolant temperature display (TRACK)

The coolant temperature is displayed from -30 °C (-22 °F) to 130 °C (266 °F) in 1 °C (1 °F) increments.

TIP

- When using Celsius, the coolant temperature display will read “-30” when the vehicle coolant temperature is below -30 °C.
- When using Fahrenheit, the coolant temperature display will read “-22” when the vehicle coolant temperature is below -22 °F.
- If the vehicle coolant temperature is too high the coolant temperature display will read “Hi”.

Lap timer (TRACK)

In TRACK theme, open the menu system and select “ Timer Ready”. The menu will exit to the main display and the “:” and “.” in the lap timer will blink to indicate the lap timer is on standby.

Press the dimmer/pass switch down towards “PASS” to start the timer.

Each press of the dimmer/pass switch will increase the lap count by 1 and reset the current lap timer.

To stop the lap timer, open the menu system and select “ Timer Stop” and the timer will return to standby.

The lap timer can be resumed by selecting “ Timer Ready” in the menu system to enter standby. Once again press the dimmer/pass switch down towards “PASS”. The timer will resume counting the previous lap.

To reset the lap timer and delete all recorded lap times and other lap data, navigate to “ TRACK Settings” → “Lap Reset” in the menu system.

TIP

The headlight does not flash when the dimmer/pass switch is pressed in TRACK.

Lap counter (TRACK)

Counts the number of times the dimmer/pass switch is pressed down towards “PASS” to a maximum of 40 before resetting.

Revolution peak hold indicator (TRACK)

This small bar momentarily appears within the tachometer to mark the most recent peak engine speed.

Shift indicator (TRACK)

A series of cells that sequentially come on and change color as engine speed increases. This indicator uses the same settings as the shift indicator light, which can be adjusted by navigating to “ Settings” → “Shift Indicator” in the menu system (see page 6-37).

LCS indicator “ / ” (TRACK)

This symbol indicates the status of the LCS (launch control system).

Icon OFF: LCS OFF, the system is not available.

: LCS standby, LCS can be activated via menu or mode switch.

: LCS Active, engine revolutions limited and the vehicle is ready to launch.

Instrument and control functions

Sector time display (TRACK)

This area of the display shows sector time information when using the Y-TRAC Rev app.

Virtual Pit Board (TRACK)

This area of the display shows messages which can be sent to the vehicle via the Y-TRAC Rev app.

Navigation Display

There are 3 display modes for route guidance: “Default View”, “Turn-by-Turn”, and “Turn List”.

Default View



In “Default View” mode: Operate the joystick up-down to zoom in/out.

Turn List

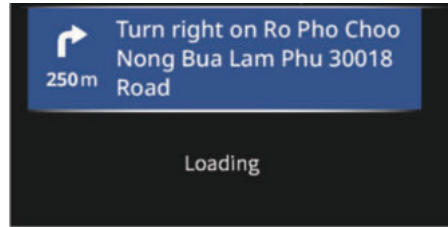

In “Turn List” mode: Operate the joystick up-down to scroll through the list of turns on the route.

Turn-by-Turn



In “Turn-by-Turn” mode: Operate the joystick left-right to cycle the information at the bottom of the display between distance remaining to

destination/estimated time to arrival and current location.

Short press “✓” to open the menu system and navigate to to “App Applications” → “Navigation” → “Change View” to switch between the display modes. (See page 6-22.)

TIP

- If the Bluetooth connection becomes unstable, the navigation display may automatically change to the “Turn-by-Turn” mode or freeze with a loading animation. When the connection improves, the navigation display will return to the former setting.
- For some smartphones, using the phone function while navigation is in progress may display a connection error after returning to the navigation display. If this happens, follow the instructions on the display. (See page 5-8.)
- If the connected smartphone’s AI assistant function is deactivated in the smartphone’s settings, and a headset is also connected, a connection error may be displayed

Instrument and control functions

when using the navigation home display (iOS only).

EUA5446

Menu system



1. Pop-up menu

The menu system for this vehicle is controlled with the joystick/home button on the left handlebar. (See page 6-5.)

The first layer of the menu is a pop-up at the bottom of the main display. Deeper layers of the menu system are viewed using the minimized display view.

To open the pop-up menu from the main display:

Short press the home button “↵”.

Menu system operation:







- Operate the joystick left-right-up-down to highlight and adjust menu items.
- Short press “✓” to select an item.

- Short press the home button “↵” to cancel/return to previous.
- Long press the home button “↵” to close the menu system.









TIP

When arrows appear “^” / “v” a menu item, operating the joystick in the direction of the arrows will adjust the selected function.

The pop-up menu is divided into the following main functions:

 “Theme”	Select the visual theme of the display. (See page 6-22.)
 “Applications”	Access the smartphone related functions. (See page 6-22.)
 “Grip Warmer” (if equipped)	Control the grip warmers. (See page 6-28.)
 “Vehicle Info”	Reset/cycle the vehicle information display items. (See page 6-28.)
 “Settings”	Adjust settings related to the vehicle’s operation. (See page 6-28.)
 “Phone” (if call active)	Open the telephone function for an active call. (See page 6-38.)

Instrument and control functions

 "Music"	Access simple pop-up audio player. (See page 6-38.)
 "Navigation"	Open the navigation display. (See page 6-39.)
 "Meter Display"	Open the main display. (See page 6-39.)
 "Turn-by-Turn"	Activate Turn-by-Turn route guidance. (See page 6-39.)
 "Turn-by-Turn OFF"	De-activate Turn-by-Turn route guidance. (See page 6-39.)
 "Timer Stop"	Stops lap timer. (See page 6-39.)
 "Timer Ready"	Resets lap timer to standby. (See page 6-39.)
 "TRACK Settings"	Shift indicator and lap timer settings. (See page 6-40.)
LCS "Launch Control"	Controls the launch control system. (See page 6-41.)

TIP

- The items contained in the menu vary depending on the currently selected theme and also whether the main display or navigation display is active.

- If the vehicle is in motion, “Theme” and “Settings” will be grayed out.
- If a smartphone is not connected to the vehicle, “Music” and “Turn-by-Turn/Turn-by-Turn OFF” will be grayed out.

“Theme”

The visual theme of the main display can be changed between five options. (See page 6-8.)

“Applications” → “Navigation”

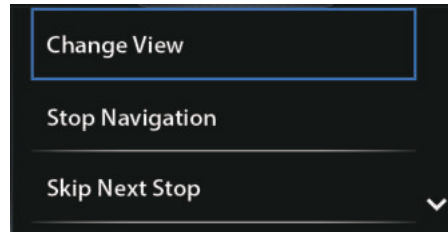

This menu contains the following commands for the navigation system:

- “Change View”
- “Stop Navigation”
- “Skip Next Stop”

- “Go Home”
- “Go to Work”
- “Favorites”
- “Nearby Gas Stations”

TIP

- Except for the commands listed above, operate the navigation system using the Garmin StreetCross app on your smartphone.
- “Change View”, “Stop Navigation” and “Skip Next Stop” are not available unless route guidance is active.

See page 6-20 for more information on the navigation system.



When a command is used to select a destination, the navigation display will

Instrument and control functions

open and show the new/updated route.

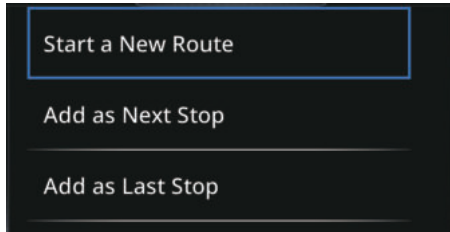

6

If route guidance is already active when a command is used to select a destination, the following options will be available:

“Start a New Route”: Cancels previous route and sets route to new destination.

“Add as Next Stop”: Adds new destination as the next stop in the current route.

“Add as Last Stop”: Adds new destination as the last stop in the current route.

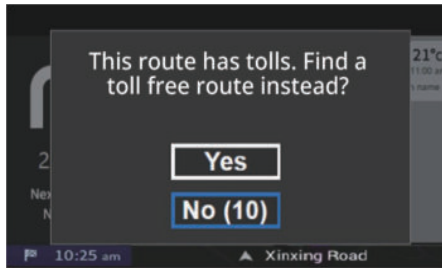

If a route requires a toll, you will be prompted to search for another route without tolls. Select “Yes” to find a route without tolls. Select “No” to accept the current route.

TIP

After 10 seconds, the route (with tolls) will be selected automatically.

“Change View”

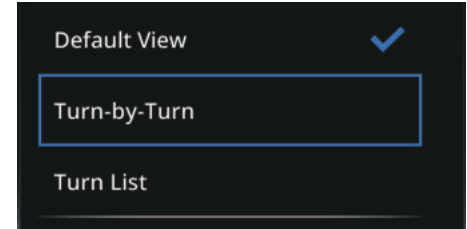

This menu changes the navigation system display mode (Default View/Turn List/Turn-by-Turn). After selection, the navigation display will open in the selected display mode.

“Stop Navigation”

Cancels the current route guidance and opens the navigation home display.

“Skip Next Stop”

Skips the next stop in your planned route and opens the navigation home display.

Instrument and control functions

“Go Home”

Sets route guidance for home location (home location must already be set in the Garmin StreetCross app).

“Go to Work”

Sets route guidance for work location (work location must already be set in the Garmin StreetCross app).

“Favorites”

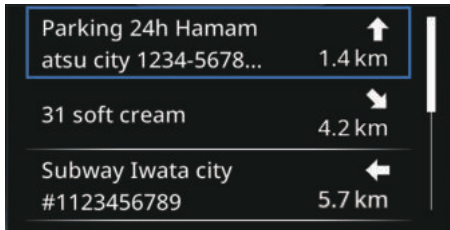

Shows a list of saved locations and their distance from current location (must have saved locations in the Garmin StreetCross).

TIP

If route guidance is in progress, arrows appear showing the direction to the saved locations. The current direction

of travel is indicated by the upwards arrow.

“Nearby Gas Stations”

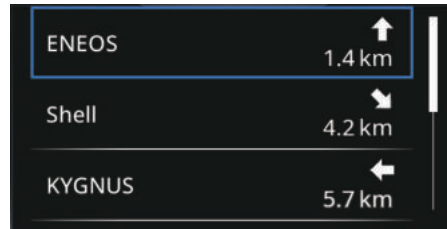

Shows a list of nearby gas stations and their distance from current location.

TIP

If route guidance is in progress, arrows appear showing direction to the gas stations. The current direction of travel is indicated by the upwards arrow.

“ Applications” → “Music”

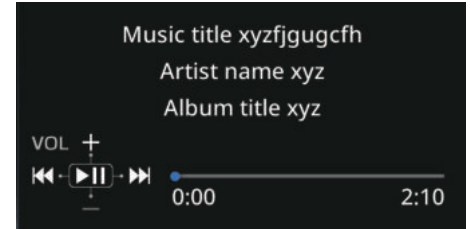

This opens an audio player which interfaces with your smartphone’s audio player app.

Operate the joystick up-down to adjust the volume.

Operate the joystick left-right to skip to the next/previous track.

Short press “✓” to play/pause the track.

TIP

- All audio track information is imported from the music player application on your smartphone.
- Depending on the smartphone and music player application, the audio player may start playing automatically, the track information

Instrument and control functions

may not display, or the next/previous track and volume adjustment may not function.

reached, older items will be deleted.

“App Applications” → “Phone”

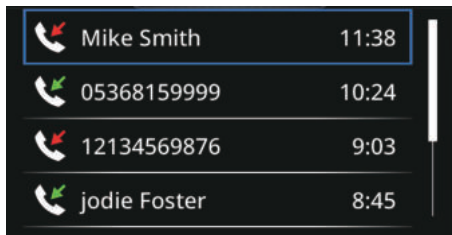

This is a list of recent telephone calls (since connection to CCU) from the connected smartphone. When this list has been viewed, the missed call indicator “☎” will disappear.

☎: Inbound missed call (red arrow)

☎: Inbound call (green arrow)

TIP

- Repeated calls for the same contact are indicated by the number next to the contact in brackets.
- The maximum number of stored items is 30; when the limit is

“App Applications” → “Weather”

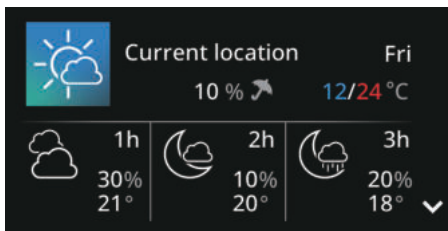

This menu displays weather information at your current location. Operate the joystick up-down to change the timeframe of the weather information (hourly/daily).

TIP

The weather information in this menu may be different than on the navigation home display.

“App Applications” → “Notification”

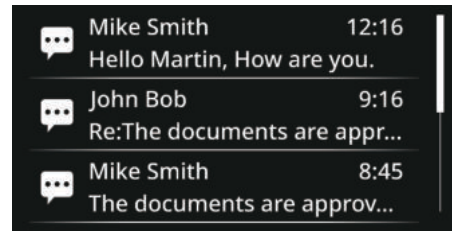

This is a list of notifications (since connection to CCU) from the connected smartphone. Select an item to read the notification message. The notification indicator “☎” will not turn off until the vehicle power is turned off.

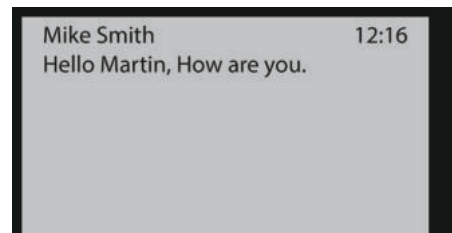

Instrument and control functions

TIP

- For some smartphones and/or applications, notifications may not function.
- The maximum number of stored items is 30. When the limit is reached, older items will be deleted.
- If a message is too long then not all of it will be displayed.
- Messages cannot be opened and read while the vehicle is in motion.
- Notification timestamps may be slightly different than when displayed on your smartphone.

“ Applications” → “Information Transfer”

This menu allows you to transfer and display images on the display using the Yamaha Motorcycle Connect app.

“ Applications” → “Connectivity Settings” → “Connection” → “Bluetooth”

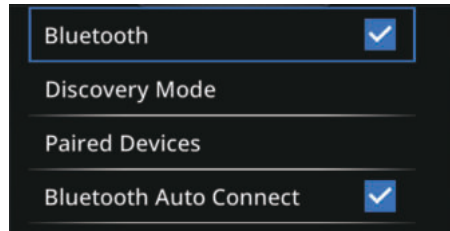

“Bluetooth”



Turns the CCU’s Bluetooth ON/OFF. The checkmark indicates ON.

“Discovery Mode”

Puts the CCU in Bluetooth discovery mode when pairing a smartphone. See page 5-3 for more information about Bluetooth pairing.

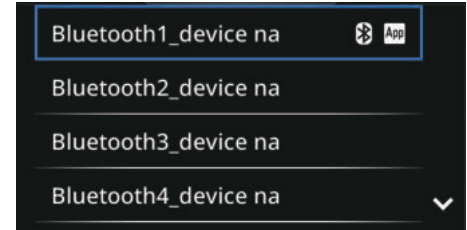
“Paired Devices”



Paired smartphones are listed here. The Yamaha Motorcycle Connect app symbol “” next to a device name indicates that the app is currently connected to the CCU. The Bluetooth symbol “” next to a device name indicates that Garmin StreetCross is currently connected to the CCU.

TIP

There is a maximum of 8 paired devices.

Select a device name for more options:

Instrument and control functions

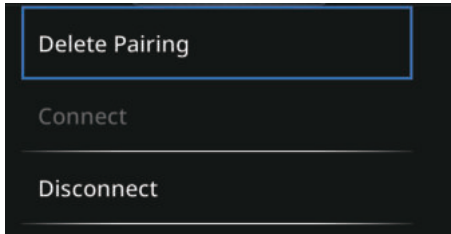

“Delete Pairing”: Deletes the selected paired device from the CCU memory.

“Connect”: Connect to the selected paired device.

“Disconnect”: Disconnect from the selected paired device.

TIP

If “Bluetooth Auto Connect” is on, the CCU may immediately reconnect to the smartphone after being disconnected.

“Bluetooth Auto Connect”

Turns the Bluetooth automatic connection ON/OFF. The checkmark indicates ON. When the auto connect is ON, the CCU will automatically connect to the last connected device. If it is not avail-

able, the CCU will attempt to connect to another device in the paired device list.

TIP

If “Bluetooth Auto Connect” is OFF, previously paired devices can be connected manually via the “Paired Devices” list.

“^[App] Applications” → “Connectivity Settings” → “System Information”

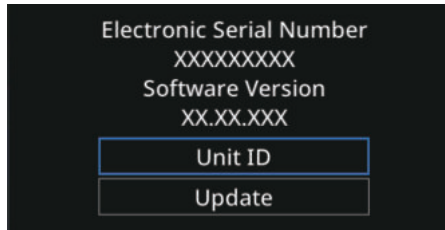

This menu displays the current system software version.

“Unit ID”



This menu contains a QR code with the CCU’s unit identification number. Short press “✓” to return to the previous menu.

TIP

The CCU’s unit ID is only required for dealer service operations.

Instrument and control functions

“**Applications**” → “**Connectivity Settings**” → “**Legal Information**”

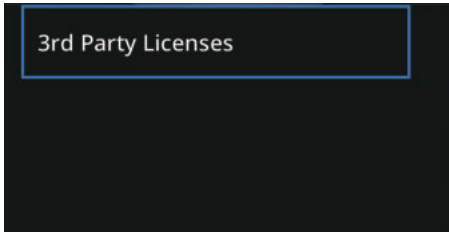

Third-party license agreements can be viewed here.

“**Grip Warmer**” (if equipped)

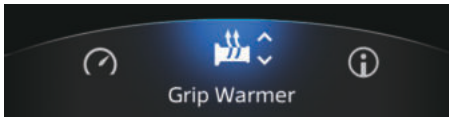

With this item highlighted, operate the joystick up-down to cycle between grip warmer OFF and 3 presets which can be customized in “**Settings**” → “**Grip Warmer Settings**”. (See page 6-37.)

With this item highlighted, long press “**✓**” to shortcut to “**Settings**” → “**Grip Warmer Settings**” where the grip

warmer presets can be further customized.

TIP

Theme4: This function is not accessible via the menu system and is instead located within the vehicle information display. The function is the same.

“**Vehicle Info**”

This allows you to adjust the vehicle information display items. (See page 6-13.)

TIP

This function is not available in Theme4.

“**Settings**”

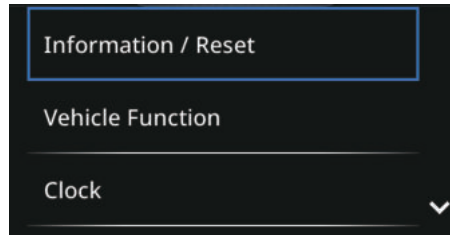

The “**Settings**” menu contains the following:

“Information / Reset”	Reset vehicle information. (See page 6-29.)
“Vehicle Function”	Adjust vehicle electronic rider aids. (See page 6-30.)
“Clock”	Adjust time/set automatic update. (See page 6-35.)
“Display”	Change display brightness and background settings. (See page 6-36.)
“Unit”	Change the display units. (See page 6-36.)
“Grip Warmer Settings” (if equipped)	Customize the grip warmer presets. (See page 6-37.)
“Shift Indicator”	Change the shift indicator settings. (See page 6-37.)
“Connectivity Settings”	Smartphone connectivity settings. (See page 6-26.)

Instrument and control functions

“ Settings” → “Information / Reset”

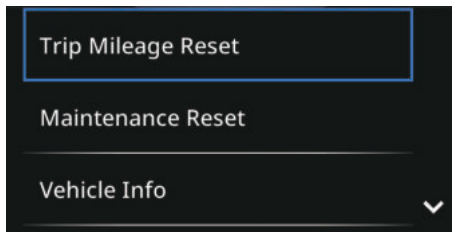

6

This menu allows the viewing and reset of tripmeters, maintenance tripmeters, vehicle information items, and the mass reset of other settings to factory defaults.

“Trip Mileage Reset”

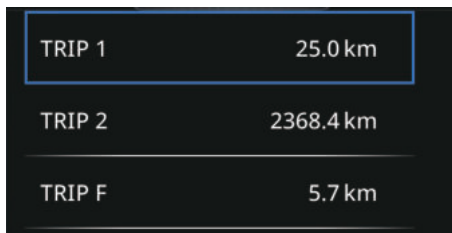

This menu allows reset of the tripmeters on the vehicle information display. Operate the joystick to highlight an item. Short press “

TIP

“TRIP F” can only be selected when the fuel is low. Otherwise the item is grayed out.

“Maintenance Reset”

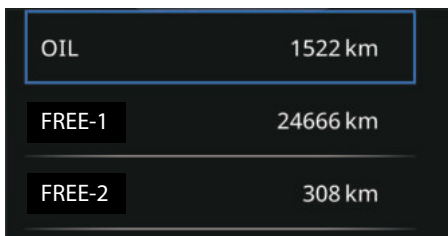

This menu allows you to record distance traveled between engine oil changes “OIL” and two other maintenance items of your choice “FREE-1” and “FREE-2”. After maintenance to one of the items has been completed, operate the joystick to highlight the

item. Short press “

“Vehicle Info”

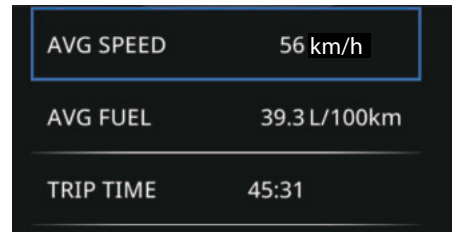

This menu allows reset of the vehicle information display items. Operate the joystick to highlight an item. Short press “

6-29

Instrument and control functions

“All Reset”

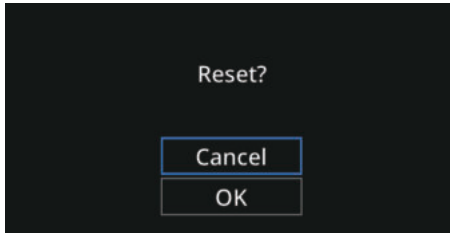

Use this menu to mass reset the multi-function meter to its default settings. This includes YRC settings, display settings, grip warmer presets, traction control, units, Bluetooth connection settings, and vehicle information display items.

Confirm by selecting “OK”.

TIP

- After a reset, the display will restart and may take several minutes to reboot.
- If “All Reset” is executed, the corresponding pairing record must be deleted from the smartphone in order to pair again.
- Before selling or changing ownership of the vehicle, reset the multi-

function meter to ensure all personal data from your smartphone (i.e., call history and contact information) is deleted.

- After the multi-function meter is reset, Bluetooth pairing records and the Yamaha Motorcycle Connect app pairing records must be deleted from your smartphone. If this is not completed, the CCU will not be able to pair with the smartphone again.

“ Settings” → “Vehicle Function” → “YRC Settings” → “YRC Modes”

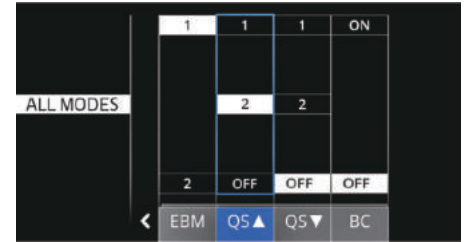
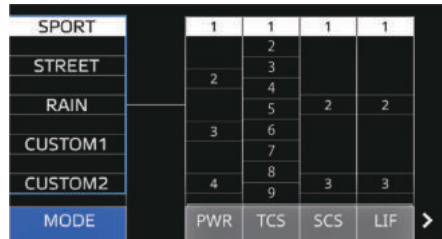

This menu allows you to:

- View the five YRC mode presets: “SPORT”, “STREET”, “RAIN”, “CUSTOM 1” and “CUSTOM 2”.
- Customize the “PWR”, “TCS”, “SCS” and “LIF” setting levels for the “CUSTOM 1” and “CUSTOM 2” YRC mode presets.
- Customize the “EBM”, “QS Δ”, “QS ∇” and “BC” setting levels for all YRC mode presets.

Operate the joystick up-down to select the YRC mode preset that you want to adjust.

Operate the joystick left-right to select the YRC item that you want to adjust. Adjust the selected YRC item by operating the joystick up-down.

Instrument and control functions

Short press “✓” to switch to a visual representation of the highlighted YRC item. Short press the home button “↵” to exit the visual representation.

Short press the home button “↵” to save and go back to the previous menu.

TIP

- The names and setting levels for “CUSTOM 1” and “CUSTOM 2” can also be changed via the Yamaha Motorcycle Connect app. (See page 6-34.)
- Adjustments to “EBM”, “QS” and “BC” settings affect all YRC mode presets.

“PWR” (Power delivery mode)

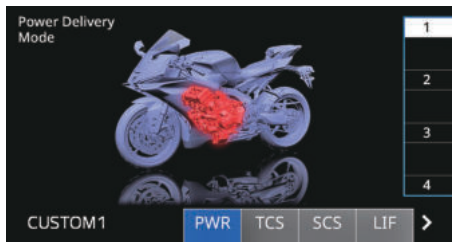

“PWR” can be set to 1, 2, 3 and 4. (See page 4-1.)

Level 1 - Sporty engine response.

Level 2 - Moderate engine response.

Level 3 - Mild engine response.

Level 4 - Rainy days or whenever less engine power is desirable.

“TCS” (Traction control system)

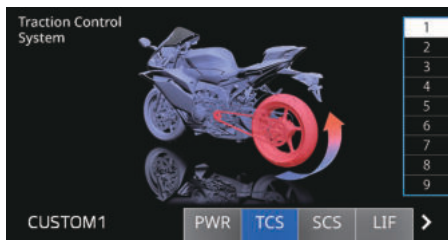

This model uses a variable traction control system. For each setting level, the farther the vehicle is leaned over, the more traction control (system intervention) is applied. There are 9 setting levels available. Level 1 applies the least system intervention, while level 9 applies the most overall traction control to reduce rear wheel slippage. (See page 4-2.)

TIP

The traction control system can only be turned off completely via “⚙ Settings” → “Vehicle Function” → “Stability Control ON/OFF”. (See page 6-34.)

“SCS” (Slide control system)

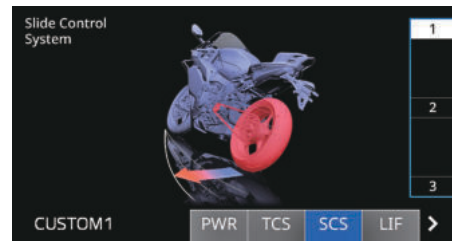

“SCS” can be set to 1, 2, and 3. Setting level 1 provides the least amount of system intervention, and setting level 3 provides the greatest amount of system intervention to reduce lateral wheel slippage. (See page 4-2.)

Level 1 - Suitable for racing more sporty riding.

Level 2 - Suitable for street riding.

Level 3 - Suitable for riding on wet or slippery surfaces.

TIP

The slide control system can only be turned off completely via “Settings” → “Vehicle Function” → “Stability Control ON/OFF”. (See page 6-34.)

“LIF” (Lift control system)

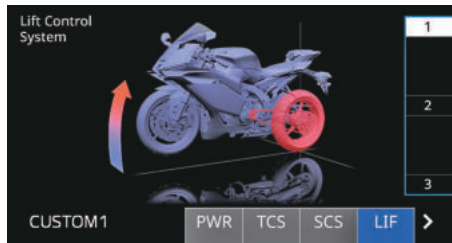

“LIF” can be set to 1, 2, and 3. Setting level 1 provides the least amount of system intervention and setting 3 most strongly reduces the amount of wheel lift. (See page 4-3.)

Level 1 - Least lift control. Suitable for more sporty riding.

Level 2 - More lift control. Suitable for sporty riding.

Level 3 - Most lift control. Suitable for street riding.

TIP

The lift control system can only be turned off completely via “Settings” → “Vehicle Function” → “Stability Control ON/OFF”. (See page 6-34.)

“EBM” (Engine brake management)

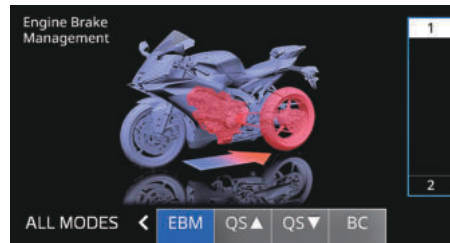

“EBM” can be set to 1 or 2. Setting level 1 provides the least amount of system intervention and therefore the most engine braking. Setting level 2 most strongly reduces engine braking. (See page 4-3.)

Level 1 - The least system intervention and therefore the most engine braking.

Level 2 - The most system intervention and therefore the least engine braking.

“QS ▲” / “QS ▼” (Quick shifter)

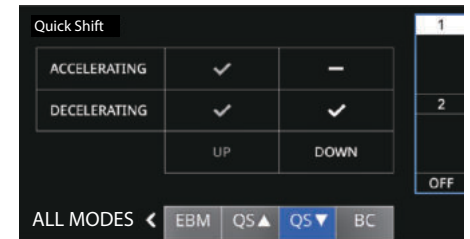

The quick shifter is divided into “QS ▲” (upshift) and “QS ▼” (downshift) sections. “QS ▲” and “QS ▼” are not linked and can be set independently. (See page 4-3.)

Setting 1: Can quick upshift only while accelerating. Can quick downshift only while decelerating.

Instrument and control functions

Setting 2: Can quick upshift while accelerating or decelerating. Can quick downshift while decelerating or accelerating.

“OFF” turns the respective upshift or downshift function off, and the clutch lever must then be used when shifting in that direction.

TIP

- Setting 1 has more limited conditions for quickshifts and may be preferable for preventing unintentional gearshifts if the shift pedal is touched accidentally when track riding.
- Setting 2 allows quickshifts under a wider array of conditions to better suit normal riding.
- “QS \triangle ” / “QS ∇ ” ON/OFF status is reflected by the quick shifter indicator. (See page 6-16.)

“BC” (Brake control system)

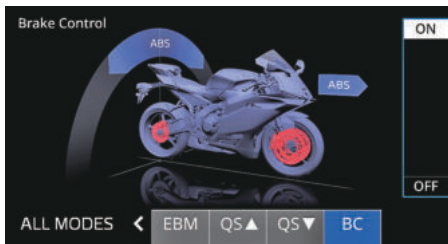

OFF: Only the standard ABS (anti-lock brake system), which adjusts brake pressure based on vehicle speed and wheel speed data. The standard ABS is designed to engage and maximize braking when the vehicle is upright.

ON: ABS (Anti-lock brake system) and cornering assist braking are both active. In addition to the standard ABS, it suppresses the increase in brake pressure when unavoidable abrupt braking occurs during cornering, making the vehicle’s recovery to upright position more gradual.

Also, additional data from the IMU regulates applied brake power depending on lean angle in order to increase the

feeling of stability and to suppress wheel lock.

See page 4-4 for more information on the brake system.

TIP

- When the rear wheel anti-lock braking system is disabled, the “BC” (brake control system) is also disabled.
- For skilled riders or when track riding, a variety of conditions may cause BC to brake faster than expected for a desired cornering speed or intended cornering line.

“**Settings**” → “**Vehicle Function**” → “**YRC Settings**” → “**TRACK YRC Modes**”

TRACK 1	1	1	1	ON	1
TRACK 2					
TRACK 3		2	2		2
TRACK 4					
	2	OFF	OFF	OFF	OFF
	EBM	QS ▲	QS ▼	BC	LCS

Instrument and control functions

This menu contains 4 additional custom YRC mode presets which are used for TRACK theme.

TIP

- The names and setting levels can also be changed via the Yamaha Motorcycle Connect app. (See page 6-34.)
- Adjustments to “EBM”, “QS” and “BC” settings affect all YRC mode presets.
- “BC” default setting is OFF in TRACK theme.

“LCS” (Launch control system)

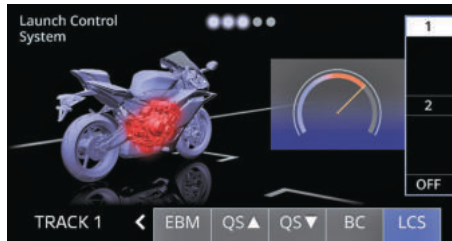

“LCS” can be set to 1, 2, or OFF. (See page 4-5.)

Level 1 - keeps engine speed from rising above 9000 r/min.

Level 2 - keeps engine speed from rising above 8000 r/min.

OFF - LCS disabled.

“ Settings” → “Vehicle Function” → “YRC Settings” → “Import / Export to App”

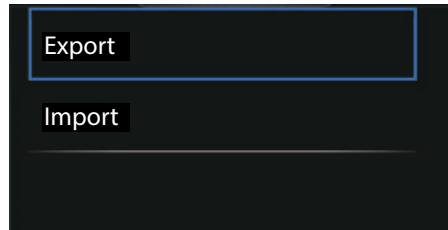

This menu allows you to import/export custom YRC mode settings using the Yamaha Motorcycle Connect app.

“ Settings” → “Vehicle Function” → “Stability Control ON/OFF”



This menu allows you to activate/deactivate the stability control systems: “Traction Control” (TCS), “Slide Control” (SCS), “Lift Control” (LIF), and “Back Slip Regulator” (BSR). (See page 4-1.)

If a system is turned off, the corresponding indicator will come on. (See page 6-16.)

Turning on/off “TCS” will turn “SCS”, “LIF” and “BSR” on/off together. The stability control system indicator light “ SC” will come on to indicate “TCS” OFF status. (See page 6-7.)

Instrument and control functions

TIP

- “Back Slip Regulator” (BSR) is disabled in TRACK theme and the item is grayed out.
- “TCS” turns on automatically when the vehicle power is turned on.

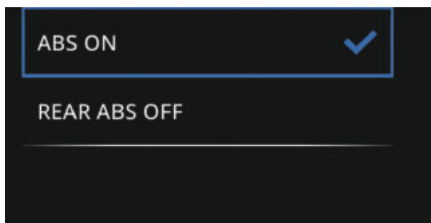

⚙️ **Settings** → **“Vehicle Function”**
→ **“ABS Settings”**



This module allows you to turn the rear wheel ABS (anti-lock braking system) on/off. The currently selected ABS mode is indicated by the REAR ABS OFF indicator “”. (See page 6-16.)

TIP

When the rear wheel anti-lock braking system is disabled, the “BC” (brake

control system) is also disabled. However, only the REAR ABS OFF indicator “” will be displayed, not the BC indicator “”.

The rear wheel ABS will remain disabled until:

- The main switch is turned off.
- The ABS is reactivated via the menu system while the vehicle is not moving.

EWA22690

WARNING

Turn the ABS off only when riding on a closed circuit course.

⚙️ **Settings** → **“Clock”**

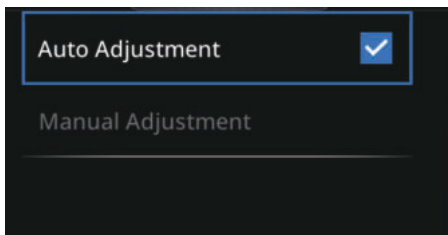

The clock can be set to auto-adjust in sync with a smartphone. “Auto Adjust-

ment” ON is indicated by the checkmark and requires a connection with the Yamaha Motorcycle Connect app. (See page 5-2.) “Manual Adjustment” allows the clock to be calibrated manually.

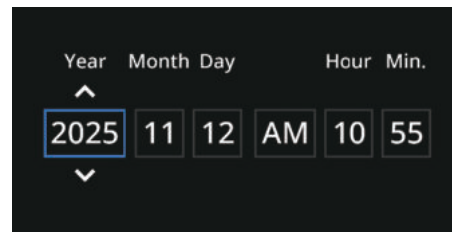

To manually adjust the clock, operate the joystick left-right to highlight an item and up-down to adjust the highlighted item. Short press “” to finalize the clock setting and then select “OK” to confirm.

Instrument and control functions

“Settings” → “Display” → “Brightness”

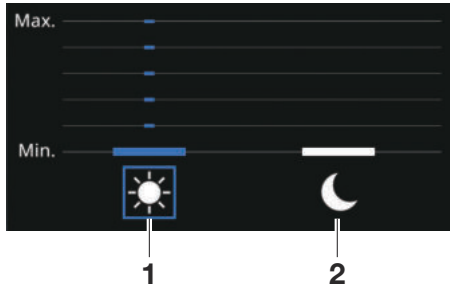

1. Day preset
2. Night preset

The multi-function meter is equipped with a sensor to detect ambient lighting conditions and automatically switch the display between day/night presets. The preset brightness levels can be customized here.

Select a preset by operating the joystick left-right and adjust its brightness level from 1-6 by operating the joystick up-down. Short press “✓” to confirm the setting and return to the previous menu.

TIP
Only adjust brightness presets in ambient light conditions which are appropriate for that preset.

“Settings” → “Display” → “Background”

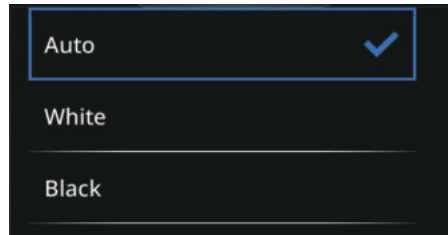

The multi-function meter is equipped with a sensor to detect ambient lighting conditions and adjust the display between day/night presets. Select “White” (day) or “Black” (night) to keep the display in that preset. Select “Auto” to enable automatic switching depending on the ambient light levels.

TIP
Only “White” (day) is available for TRACK theme.

“Settings” → “Unit”

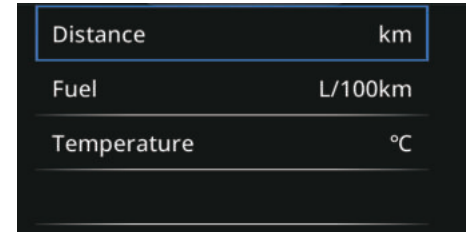

The display units can be customized as follows:

- “Distance”: “km” or “mile”
- “Fuel”: “km/L”, “L/100km” or “MPG”
- “Temperature”: “°C” or “°F”

When “mile” is selected for the distance unit, the fuel consumption unit is automatically changed to “MPG”. At this time, the “Fuel” is grayed out and cannot be selected.

Instrument and control functions

“Settings” → “Grip Warmer Settings” (if equipped)



The three grip warmer presets can be customized here. Short press “✓” to select a preset and then adjust its heat level from 1-10 by operating the joystick up-down. Short press “✓” to confirm the setting and return to the previous menu.

“Settings” → “Shift Indicator”

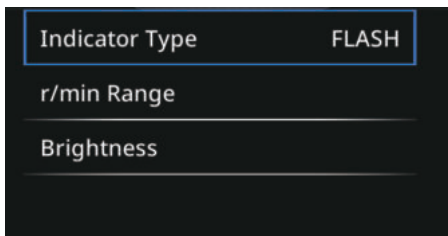

This menu contains settings for the shift indicator light.

“Indicator Type”

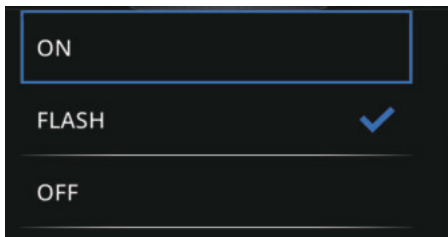

Select “ON” to have the indicator come on at the final r/min. Select “FLASH” to have the indicator start flashing at the initial r/min. When the final r/min is reached, the indicator light will start

flashing at a higher frequency. Select “OFF” to turn the indicator off. Short press “✓” to select the highlighted option and return to the previous menu.

TIP

The shift indicator light will come on or flash as a demonstration of each setting in this menu as it is selected.

“r/min Range”

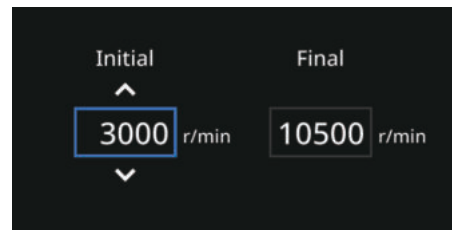

Select the r/min at which the shift indicator light will come on. The operational range is 3000–10500 r/min. It can be adjusted by 250 r/min increments. Short press “✓” to confirm the setting and return to the previous menu.

Instrument and control functions

TIP

- The “Initial” r/min cannot be higher than the “Final” r/min.
- The shift indicator light does not come on when in neutral.
- The shift indicator does not come on in 6th gear except when in TRACK mode.

“Brightness”

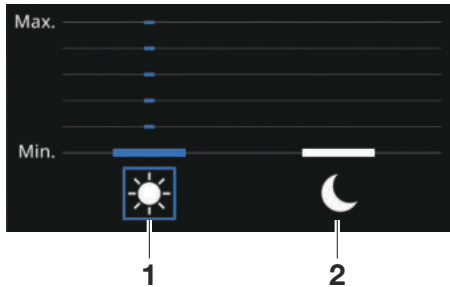

1. Day preset
2. Night preset

Select the day/night brightness levels of the shift indicator light from 1-6 by operating the joystick up-down. Short press “✓” to confirm the setting and return to the previous menu.

TIP

Only adjust brightness presets in ambient light conditions which are appropriate for that preset.

“Phone” (if call active)

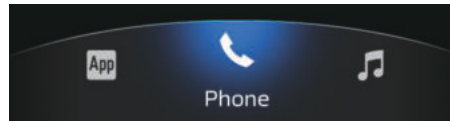

Selecting this menu opens an active call display. The contact name and call time are displayed.

Operate the joystick up-down to adjust the call volume.

Short press “✓” to end the call.

TIP

Call volume control and/or ending call via the vehicle is not available for all types of smartphones. If this function is unavailable, the volume adjustment and end call graphics will be grayed out. If this occurs, the call can be controlled directly on your smartphone.

“Music”

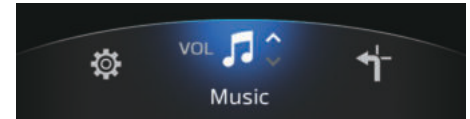

While this item is shown in the menu, operate the joystick up-down to adjust the volume.

Short press “✓” to open additional audio controls.



This opens an audio player which interfaces with your smartphone's audio player app.

Operate the joystick up-down to adjust the volume.

Operate the joystick left-right to skip to the next/previous track.

Short press “✓” to play/pause the track.

Instrument and control functions

TIP

- All audio track information is imported from the music player application on your smartphone.
- Depending on the smartphone and music player application, the audio player may start playing automatically, or the next/previous track and volume adjustment may not function.
- Theme4: This function is not accessible via the menu system and is instead located within the vehicle information display. The function is the same.

“Navigation”

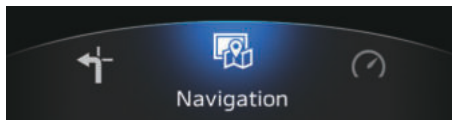

This opens the navigation display. This menu option is only available from the main display.

“Meter Display”

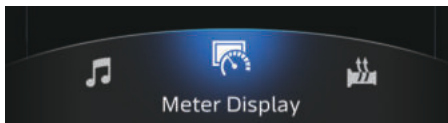

This opens the main display. This menu option is only available from the navigation display.

“Turn-by-Turn / Turn-by-Turn OFF”



This activates/deactivates a turn-by-turn route guidance at the bottom of the main display.

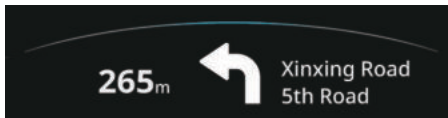

This menu option is only available from the main display.

“Timer Ready”



Sets the lap timer to standby. The menu will exit to the main display and the “:” and “.” in the lap timer will blink to indicate the lap timer is on standby. This menu option is only available in TRACK.

“Timer Stop”



Pauses the lap timer and returns to the main display. The lap timer can be resumed by once again selecting “Timer Ready”. This menu option is only available in TRACK.

Instrument and control functions

“ TRACK Settings” → “Shift Indicator Mode”

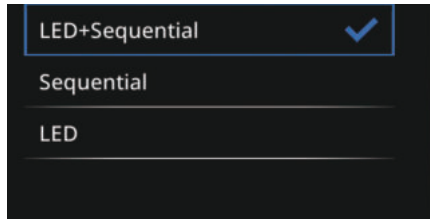

This module enables you to choose between the LED shift indicator light (see page 6-6) and the shift indicator located on the TFT display in the TRACK theme (see page 6-8).

“LED+Sequential”: Both shift indicators are active.

“Sequential”: Only TFT indicator is active.

“LED”: Only LED shift indicator light is active.

“ TRACK Settings” → “Peak Rev Indicator”

This item activates/deactivates the revolution hold indicator. (See page 6-8.)

“ TRACK Settings” → “Auto Lap Timer”

Select this item to activate the auto lap timer. The auto lap timer requires setup via the Y-TRAC Rev app.

TIP _____

While the auto lap timer is selected, the normal lap timer will not be available and the menu options will be grayed out. Lap times will not be recorded in “Lap Time”.

“ TRACK Settings” → “Lap Time”

This module contains recorded lap times the date of the first recorded lap and additional lap data.

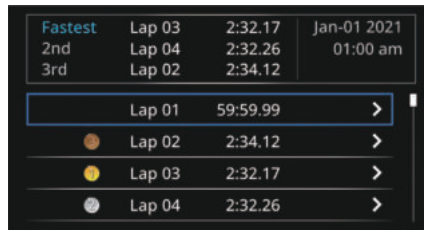

Fastest	Lap 03	2:32.17	Jan-01 2021
2nd	Lap 04	2:32.26	01:00 am
3rd	Lap 02	2:34.12	
	Lap 01	59:59.99	
	Lap 02	2:34.12	
	Lap 03	2:32.17	
	Lap 04	2:32.26	

Operate the joystick in the direction of the arrows to access additional lap data and delete lap data individually.

TIP _____

The speed displayed here may differ from the speedometer.



“ TRACK Settings” → “Lap Reset”

This item deletes all recorded lap times and additional recorded lap data and resets the lap timer.

Instrument and control functions

“LCS Launch Control”

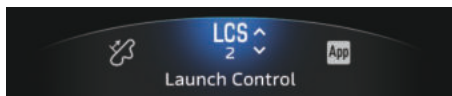

Highlight this item and operate the joystick up/down to adjust the LCS (launch control system) setting levels between OFF, 1, 2. If the setting level is 1 or 2, short press “✓” to select this item and activate the LCS (launch control system).

See page 4-5 for more information on the launch control system.

Clutch lever

To disengage the drivetrain from the engine, such as when shifting gears, pull the clutch lever toward to the handlebar. Release the lever to engage the clutch and transmit power to the rear wheel.

TIP

The lever should be pulled rapidly and released slowly for smooth shifting. (See page 8-3.)

Adjusting the clutch lever

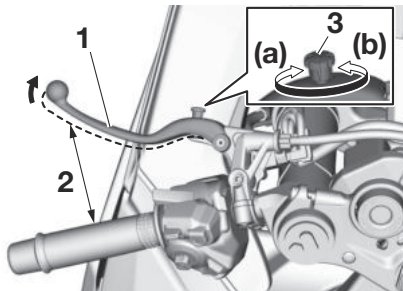

1. Clutch lever
2. Distance
3. Clutch lever position adjusting knob

EAUA1802

To adjust the distance between the clutch lever and the handlebar, gently push the lever away from the handlebar and rotate the clutch lever position adjusting knob.

Turn the adjusting knob in direction (a) to increase the distance. Turn the adjusting knob in direction (b) to decrease the distance.

EAU83694

Shift pedal

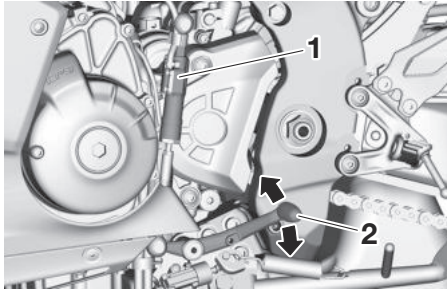

1. Shift rod
2. Shift pedal

The shift pedal is located on the left side of the motorcycle. To shift the transmission to a higher gear, move the shift pedal up. To shift the transmission to a lower gear, move the shift pedal down. (See page 8-3.)

The shift rod is equipped with a shift sensor, which is part of the quick shifter. The shift sensor reads up and down movement, as well as the strength of the input force when the shift pedal is moved.

TIP

To prevent unintended shifts, the quick shifter is programmed to ignore unclear input signals. Therefore, be sure to shift using quick and sufficiently forceful inputs.

EAU93083

Brake lever

The brake lever is located on the right side of the handlebar. To apply the front brake, pull the lever toward the throttle grip.

Adjusting the brake lever

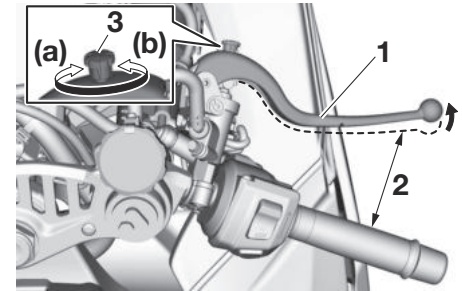

1. Brake lever
2. Distance
3. Brake lever position adjusting knob

To adjust the distance between the brake lever and the handlebar, gently push the lever away from the handlebar and rotate the brake lever position adjusting knob.

Instrument and control functions

Turn the adjusting knob in direction (a) to increase the distance. Turn the adjusting knob in direction (b) to decrease the distance.

Brake pedal

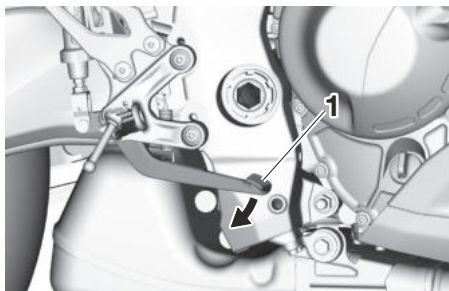

1. Brake pedal

The brake pedal is located on the right side of the motorcycle. To apply the rear brake, press down on the brake pedal.

EAU12944

Brake system

This vehicle is equipped with an integrated anti-lock brake system (ABS).

How to operate the brakes:

Operate the brake lever and brake pedal the same as you would conventional brakes. If wheel slip is detected while braking, ABS will activate and a pulsating sensation may be felt at the brake lever or brake pedal. Continue to apply the brakes and let the ABS work. Do not pump the brakes as this will reduce braking effectiveness.

TIP

The ABS performs a self-diagnostic test when the vehicle starts off and reaches a speed of 10 km/h (6 mi/h). During this test, a clicking noise may be audible from the hydraulic control unit, and some vibration may be felt at the brake lever or pedal, but this is normal.

Anti-lock brake system (ABS)

The anti-lock brake system (ABS) acts on the front and rear brakes independently.

EAU5990

WARNING

EWA16051

Always keep a sufficient distance from the vehicle ahead to match the riding speed even with ABS.

- The ABS performs best with long braking distances.
- On certain surfaces, such as rough or gravel roads, the braking distance may be longer with the ABS than without.

NOTICE

ECA20100

Be careful not to damage the wheel sensor or wheel sensor rotor; otherwise, improper performance of the ABS will result.

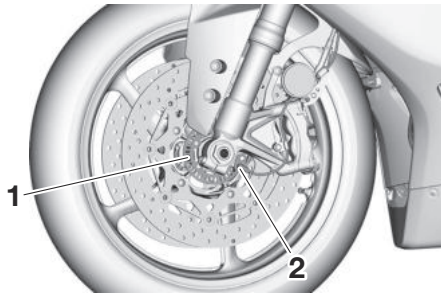

1. Front wheel sensor rotor

2. Front wheel sensor

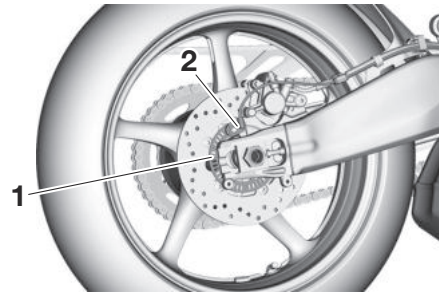

1. Rear wheel sensor rotor
2. Rear wheel sensor

This vehicle is equipped with various electronic control settings for the braking system. For more information see page 4-4.

Fuel tank cap

EAU13078



1. Fuel tank cap lock cover
2. Unlock.

To open the fuel tank cap

Open the fuel tank cap lock cover, insert the key, and then turn it 1/4 turn clockwise. The lock will be released and the fuel tank cap can be opened.

To close the fuel tank cap

With the key still inserted, push down the fuel tank cap. Turn the key 1/4 turn counterclockwise, remove it, and then close the lock cover.

TIP

The fuel tank cap cannot be closed unless the key is in the lock. In addition,

Instrument and control functions

the key cannot be removed if the cap is not properly closed and locked.

EWA11092

WARNING

Make sure that the fuel tank cap is properly closed after filling fuel. Leaking fuel is a fire hazard.

Fuel

Make sure there is sufficient gasoline in the tank.

EAU13222

EWA10882

WARNING

Gasoline and gasoline vapors are extremely flammable. To avoid fires and explosions and to reduce the risk of injury when refueling, follow these instructions.

1. Before refueling, turn off the engine and be sure that no one is sitting on the vehicle. Never refuel while smoking, or while in the vicinity of sparks, open flames, or other sources of ignition such as the pilot lights of water heaters and clothes dryers.
2. Do not overfill the fuel tank. When refueling, be sure to insert the pump nozzle into the fuel tank filler tube. Stop filling when the fuel reaches the bottom of the filler tube. Because fuel expands when it heats up, heat from the engine or the sun can cause fuel to spill out of the fuel tank.

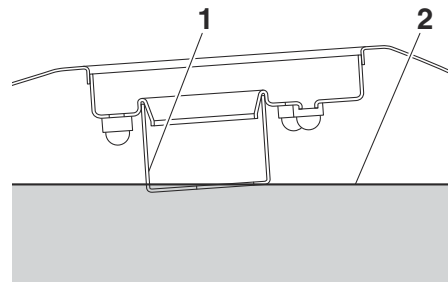

1. Fuel tank filler tube
2. Maximum fuel level
3. Wipe up any spilled fuel immediately. **NOTICE: Immediately wipe off spilled fuel with a clean, dry, soft cloth, since fuel may deteriorate painted surfaces or plastic parts.**^[ECA10072]
4. Be sure to securely close the fuel tank cap.

EWA15152

WARNING

Gasoline is poisonous and can cause injury or death. Handle gasoline with care. Never siphon gasoline by mouth. If you should swallow some gasoline or inhale a lot of gasoline vapor, or get some gasoline in

your eyes, see your doctor immediately. If gasoline spills on your skin, wash with soap and water. If gasoline spills on your clothing, change your clothes.

EAU86081

Your Yamaha engine was designed to use unleaded gasoline with a research octane number of 95 or higher. If engine knocking or pinging occurs, use a gasoline of a different brand or higher octane rating.

Recommended fuel:

Unleaded gasoline (E10 acceptable)

Octane number (RON):

95

Fuel tank capacity:

14 L (3.7 US gal, 3.1 Imp.gal)

Fuel tank reserve:

2.5 L (0.66 US gal, 0.55 Imp.gal)

Gasohol

There are two types of gasohol: gasohol containing ethanol and that containing methanol. Gasohol containing ethanol can be used if the ethanol content does not exceed 10% (E10). Gasohol

containing methanol is not recommended by Yamaha because it can cause damage to the fuel system or vehicle performance problems.

ECA11401

NOTICE

Use only unleaded gasoline. The use of leaded gasoline will cause severe damage to internal engine parts, such as the valves and piston rings, as well as to the exhaust system.

Fuel tank overflow hose

EAU86161

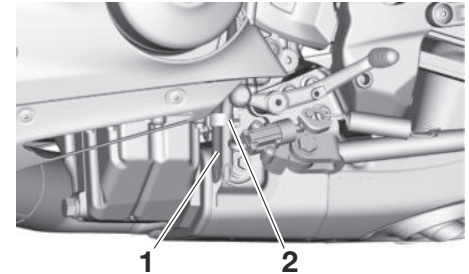

1. Fuel tank overflow hose
2. Clamp

The overflow hose drains excess gasoline and directs it safely away from the vehicle.

Before operating the vehicle:

- Check the fuel tank overflow hose connection.
- Check the fuel tank overflow hose for cracks or damage, and replace it if necessary.
- Make sure that the fuel tank overflow hose is not blocked, and clean it if necessary.
- Make sure that the fuel tank overflow hose is positioned as shown.

Instrument and control functions

TIP

See page 9-11 for canister information.

EAU13435

Catalytic converter

The exhaust system contains catalytic converter(s) to reduce harmful exhaust emissions.

EWA10863

WARNING

The exhaust system is hot after operation. To prevent a fire hazard or burns:

- Do not park the vehicle near possible fire hazards such as grass or other materials that easily burn.
- Park the vehicle in a place where pedestrians or children are not likely to touch the hot exhaust system.
- Make sure that the exhaust system has cooled down before doing any maintenance work.
- Do not allow the engine to idle more than a few minutes. Long idling can cause a build-up of heat.

EAU5170

Seats

Passenger seat

To remove the passenger seat

1. Insert the key into the seat lock, and then turn it clockwise.

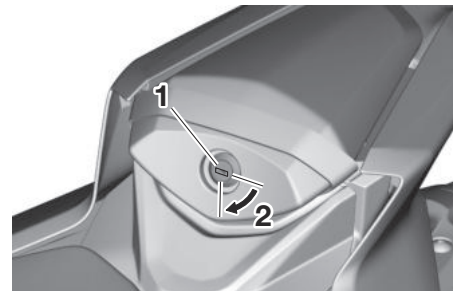

1. Seat lock
2. Unlock.

2. Lift the front of the passenger seat and pull it forward.

To install the passenger seat

1. Insert the projection on the rear of the passenger seat as shown.

Instrument and control functions

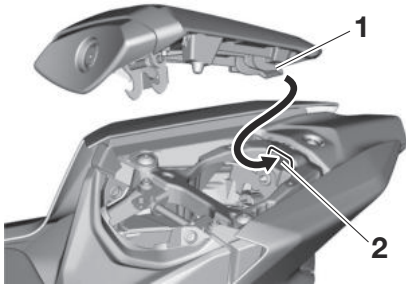

1. Projection
2. Seat holder

2. Insert the key into the seat lock, and then turn it clockwise. While holding the key turned in the clockwise position, push the front of the seat down to lock it in place.
3. Rotate the key counterclockwise to its inserted position and remove the key.

Rider seat

To remove the rider seat

1. Remove the passenger seat, and then remove the center cover by removing the quick fasteners.

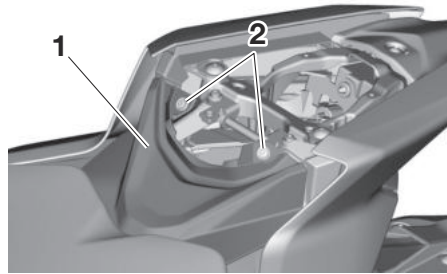

1. Center cover
2. Quick fastener

2. Remove the bolts and lift the rear of the rider seat to remove the rider seat.

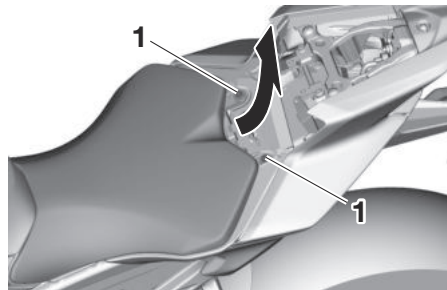

1. Bolt

To install the rider seat

1. Insert the projection on the front of the rider seat into the seat holder as shown, and then place the seat in the original position.

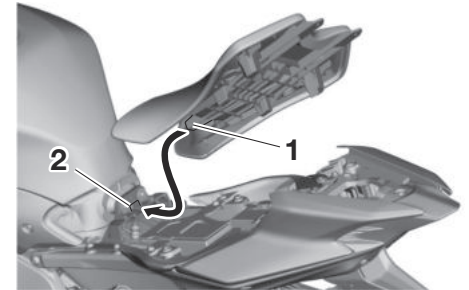

1. Projection
2. Seat holder

2. Install the rider seat bolts.
3. Insert the projections as shown, and then place the center cover in the original position.

Instrument and control functions

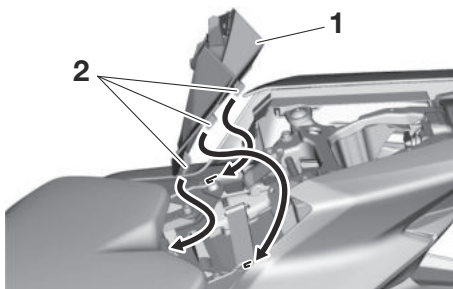

1. Center cover
2. Projection
3. Install the passenger seat.
4. Install the quick fasteners.
5. Install the passenger seat.

TIP

Make sure that the seats are properly secured before riding.

EAU91560

Rider footrest position

The rider footrests can be adjusted to one of two positions. From the factory, the footrests are in the low position. Have a Yamaha dealer adjust the positions of the rider footrests.

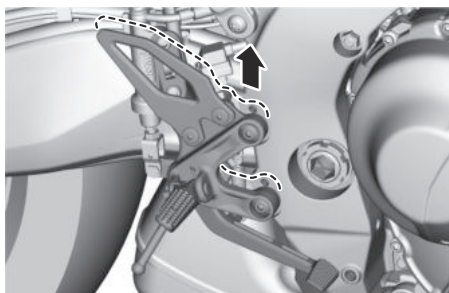
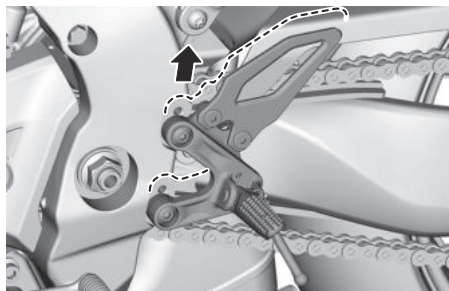

EAU62551

Storage compartment

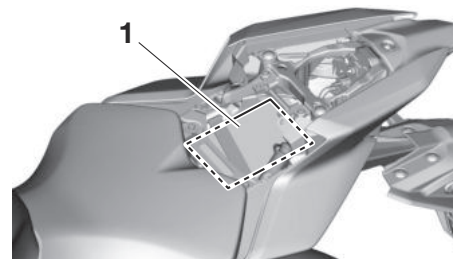

1. Storage compartment

The storage compartment is located under the passenger seat. (See page 6-47.)

When storing documents or other items in the storage compartment, be sure to wrap them in a plastic bag so that they will not get wet. When washing the vehicle, be careful not to let any water enter the storage compartment.

EWA15402

! WARNING

Do not exceed the maximum load of 164 kg (363 lb) for the vehicle.

Rear view mirrors

EAU39672

The rear view mirrors of this vehicle can be folded forward or backward for parking in narrow spaces. Fold the mirrors back to their original position before riding.

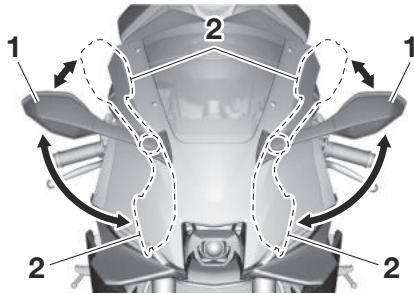

1. Riding position
2. Parking position

EWA14372

WARNING

Be sure to fold the rear view mirrors back to their original position before riding.

Adjusting the front fork

EUA5231

EWA10181

WARNING

Always adjust both fork legs equally, otherwise poor handling and loss of stability may result.

This front fork is equipped with spring preload adjuster, rebound damping force adjuster, compression damping force adjuster (for fast compression damping) and compression damping force adjuster (for slow compression damping).

ECA22472

NOTICE

- Use extra care to avoid scratching the anodized finish when making suspension adjustments.
- To avoid damaging the suspension's internal mechanisms, do not attempt to turn beyond the maximum or minimum settings.

Spring preload

Turn the adjuster in direction (a) to increase the spring preload.

Turn the adjuster in direction (b) to decrease the spring preload.

To set the spring preload, turn the adjuster in direction (b) until it stops, and then count the turns in direction (a).

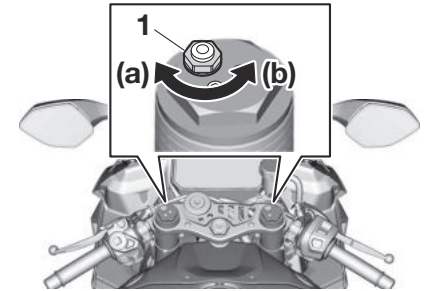

1. Spring preload adjuster

Spring preload setting:

Minimum (soft):

0 turn(s) in direction (a)

Standard:

3 turn(s) in direction (a)

Maximum (hard):

15 turn(s) in direction (a)

TIP

When turning the spring preload adjuster in direction (a), it may turn beyond the stated specifications, however such adjustments are

Instrument and control functions

ineffective and may damage the suspension.

Rebound damping force

The rebound damping force is adjusted on the right fork leg only.

Turn the adjuster in direction (a) to increase the rebound damping force.

Turn the adjuster in direction (b) to decrease the rebound damping force.

To set the rebound damping force, turn the adjuster in direction (a) until it stops, and then count the clicks in direction (b).

TIP

Be sure to perform this adjustment on the right fork leg.

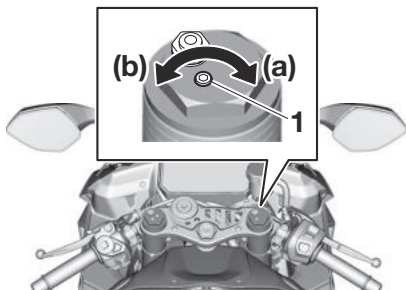

1. Rebound damping force adjuster

Rebound damping setting:

- Minimum (soft):
23 click(s) in direction (b)
- Standard:
7 click(s) in direction (b)
- Maximum (hard):
1 click(s) in direction (b)

TIP

- When turning the damping force adjuster in direction (a), the 0 click position and the 1 click position may be the same.
- When turning the damping force adjuster in direction (b), it may click beyond the stated specifications, however such adjustments are ineffective and may damage the suspension.

Compression damping force

Fast compression damping force

The compression damping force is adjusted on the left fork leg only.

Turn the adjuster in direction (a) to increase the compression damping force.

Turn the adjuster in direction (b) to decrease the compression damping force.

To set the compression damping force, turn the adjuster in direction (a) until it stops, and then count the clicks in direction (b).

TIP

Be sure to perform this adjustment on the left fork leg.

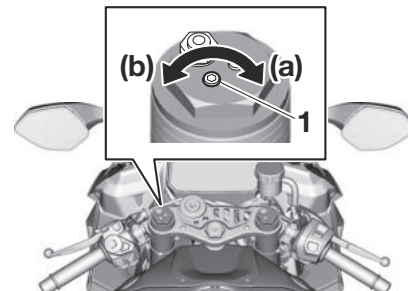

1. Fast compression damping force adjuster

Fast compression damping setting:

Minimum (soft):

23 click(s) in direction (b)

Standard:

8 click(s) in direction (b)

Maximum (hard):

1 click(s) in direction (b)

TIP

- When turning the damping force adjuster in direction (a), the 0 click position and the 1 click position may be the same.
- When turning the damping force adjuster in direction (b), it may click beyond the stated specifications, however such adjustments are ineffective and may damage the suspension.

Slow compression damping force

The compression damping force is adjusted on the left fork leg only.

Turn the adjuster in direction (a) to increase the compression damping force.

Turn the adjuster in direction (b) to decrease the compression damping force.

To set the compression damping force, turn the adjuster in direction (a) until it stops, and then count the clicks in direction (b).

TIP

Be sure to perform this adjustment on the left fork leg.

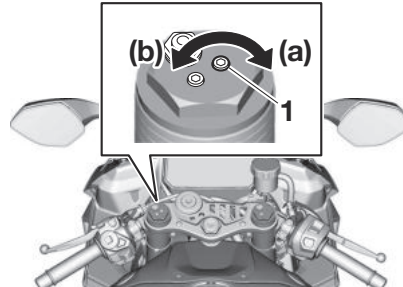

1. Slow compression damping force adjuster

Slow compression damping setting:

Minimum (soft):

14 click(s) in direction (b)

Standard:

7 click(s) in direction (b)

Maximum (hard):

1 click(s) in direction (b)

TIP

- When turning the damping force adjuster in direction (a), the 0 click position and the 1 click position may be the same.
- When turning the damping force adjuster in direction (b), it may click beyond the stated specifications, however such adjustments are ineffective and may damage the suspension.

Instrument and control functions

Adjusting the shock absorber assembly

EUAU5190

The shock absorber assembly has adjusters for spring preload, rebound damping, and both fast/slow compression damping.

ECA10102

NOTICE

To avoid damaging the mechanism, do not attempt to turn beyond the maximum or minimum settings.

Spring preload

Turn the adjuster in direction (a) to increase the spring preload.

Turn the adjuster in direction (b) to decrease the spring preload.

To set the spring preload, turn the adjuster in direction (b) until it stops, and then count the clicks in direction (a).

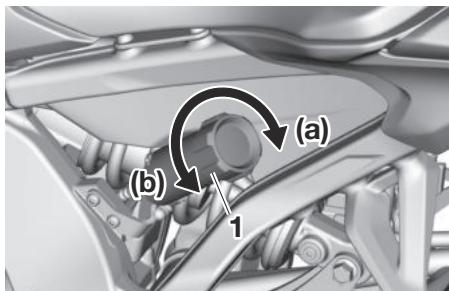

1. Spring preload adjuster

Spring preload setting:

Minimum (soft):

1 click(s) in direction (a)

Standard:

14 click(s) in direction (a)

Maximum (hard):

24 click(s) in direction (a)

TIP

- When turning the spring preload adjuster in direction (b), the 0 click position and the 1 click position may be the same.
- When turning the spring preload adjuster in direction (a), it may click beyond the stated specifications, however such adjustments are in-

effective and may damage the suspension.

Rebound damping force

Turn the adjuster in direction (a) to increase the rebound damping force.

Turn the adjuster in direction (b) to decrease the rebound damping force.

To set the rebound damping force, turn the adjuster in direction (a) until it stops, and then count the clicks in direction (b).

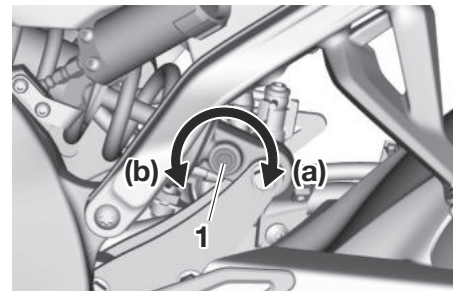

1. Rebound damping force adjuster

Rebound damping setting:

- Minimum (soft):
23 click(s) in direction (b)
- Standard:
6 click(s) in direction (b)
- Maximum (hard):
1 click(s) in direction (b)

TIP

- When turning the damping force adjuster in direction (a), the 0 click position and the 1 click position may be the same.
- When turning the damping force adjuster in direction (b), it may click beyond the stated specifications, however such adjustments are ineffective and may damage the suspension.

Compression damping force

Fast compression damping force

Turn the adjuster in direction (a) to increase the compression damping force.

Turn the adjuster in direction (b) to decrease the compression damping force.

To set the compression damping force, turn the adjuster in direction (a) until it stops, and then count the turns in direction (b).

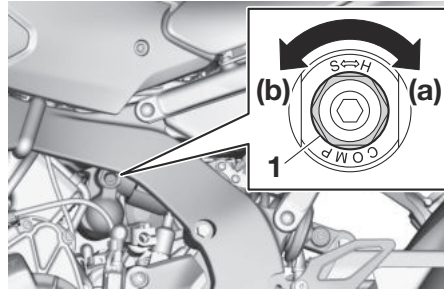

1. Fast compression damping force adjuster

Fast compression damping setting:

- Minimum (soft):
5.5 turn(s) in direction (b)
- Standard:
3 turn(s) in direction (b)
- Maximum (hard):
0 turn(s) in direction (b)

TIP

When turning the adjuster in direction (b), it may turn beyond the stated specifications, however such adjustments are ineffective and may damage the suspension.

Slow compression damping force

Turn the adjuster in direction (a) to increase the compression damping force.

Turn the adjuster in direction (b) to decrease the compression damping force.

To set the compression damping force, turn the adjuster in direction (a) until it stops, and then count the clicks in direction (b).

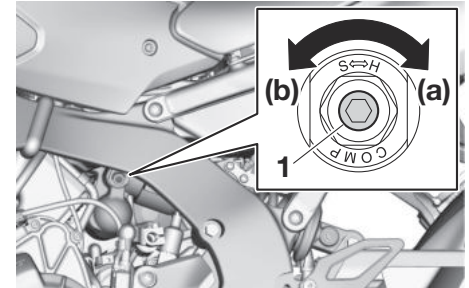

1. Slow compression damping force adjuster

Slow compression damping setting:

- Minimum (soft):
18 click(s) in direction (b)
- Standard:
11 click(s) in direction (b)
- Maximum (hard):
1 click(s) in direction (b)

Instrument and control functions

TIP

- When turning the adjuster in direction (a), the 0 click position and the 1 click position may be the same.
- When turning the adjuster in direction (b), it may click beyond the stated specifications, however such adjustments are ineffective and may damage the suspension.

EWA10222

WARNING

6

This shock absorber assembly contains highly pressurized nitrogen gas. Read and understand the following information before handling the shock absorber assembly.

- Do not tamper with or attempt to open the cylinder assembly.
- Do not subject the shock absorber assembly to an open flame or other high heat source. This may cause the unit to explode due to excessive gas pressure.
- Do not deform or damage the cylinder in any way. Cylinder damage will result in poor damping performance.

- Do not dispose of a damaged or worn-out shock absorber assembly yourself. Take the shock absorber assembly to a Yamaha dealer for any service.
-

EAU70642

DC connectors

This vehicle is equipped with additional wiring and DC connector(s) for the installation of optional electric accessories.

Consult a Yamaha dealer for more information regarding the location and capacity of the DC connector(s) and about what accessories are capable of being installed.

USB Type-C jack

EUA1832

This model is equipped with a 5 V 3 A USB Type-C jack. The USB Type-C jack can be used when the main switch is on.

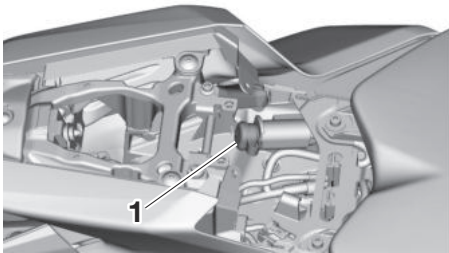

1. USB jack cap

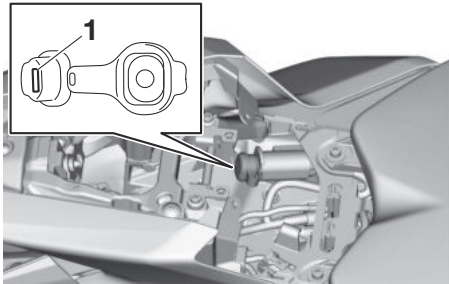

1. USB Type-C jack

TIP

- Do not use the USB Type-C jack when the engine is off or it will drain the battery.
- Under some conditions, the device battery level may drop even while the USB is plugged in.

ECA28531

NOTICE

- To protect the USB Type-C jack from water and collisions, install the cap when the jack is not being used.
- To prevent damage, avoid applying excessive force when opening and closing the USB jack cap.
- Ensure the USB jack cap is properly installed and do not use the USB Type-C jack when it rains or when washing the vehicle. If the USB Type-C jack gets wet, please dry it with the vehicle turned off before using it.
- Do not put tension or apply force to cables attached to the USB

Type-C jack as it may cause damage.

Instrument and control functions

Sidestand

EAU15306

The sidestand is located on the left side of the frame. Raise the sidestand or lower it with your foot while holding the vehicle upright.

TIP

The built-in sidestand switch is part of the ignition circuit cut-off system, which cuts the ignition in certain situations. (See the following section for an explanation of the ignition circuit cut-off system.)

EWA10242

WARNING

The vehicle must not be ridden with the sidestand down, or if the sidestand cannot be properly moved up (or does not stay up), otherwise the sidestand could contact the ground and distract the operator, resulting in a possible loss of control. Yamaha's ignition circuit cut-off system has been designed to assist the operator in fulfilling the responsibility of raising the sidestand before starting off. Therefore, check this system regularly and have a Yamaha

dealer repair it if it does not function properly.

EAU1272

Ignition circuit cut-off system

This system prevents in-gear engine starts unless the clutch lever is pulled and the sidestand is up. Also, it will stop the running engine should the sidestand be lowered while the transmission is in gear.

Periodically check this system via the following procedure.

TIP

- This check is most reliable if performed with a warmed-up engine.
 - See pages 6-2 and 6-3 for switch operation information.
-

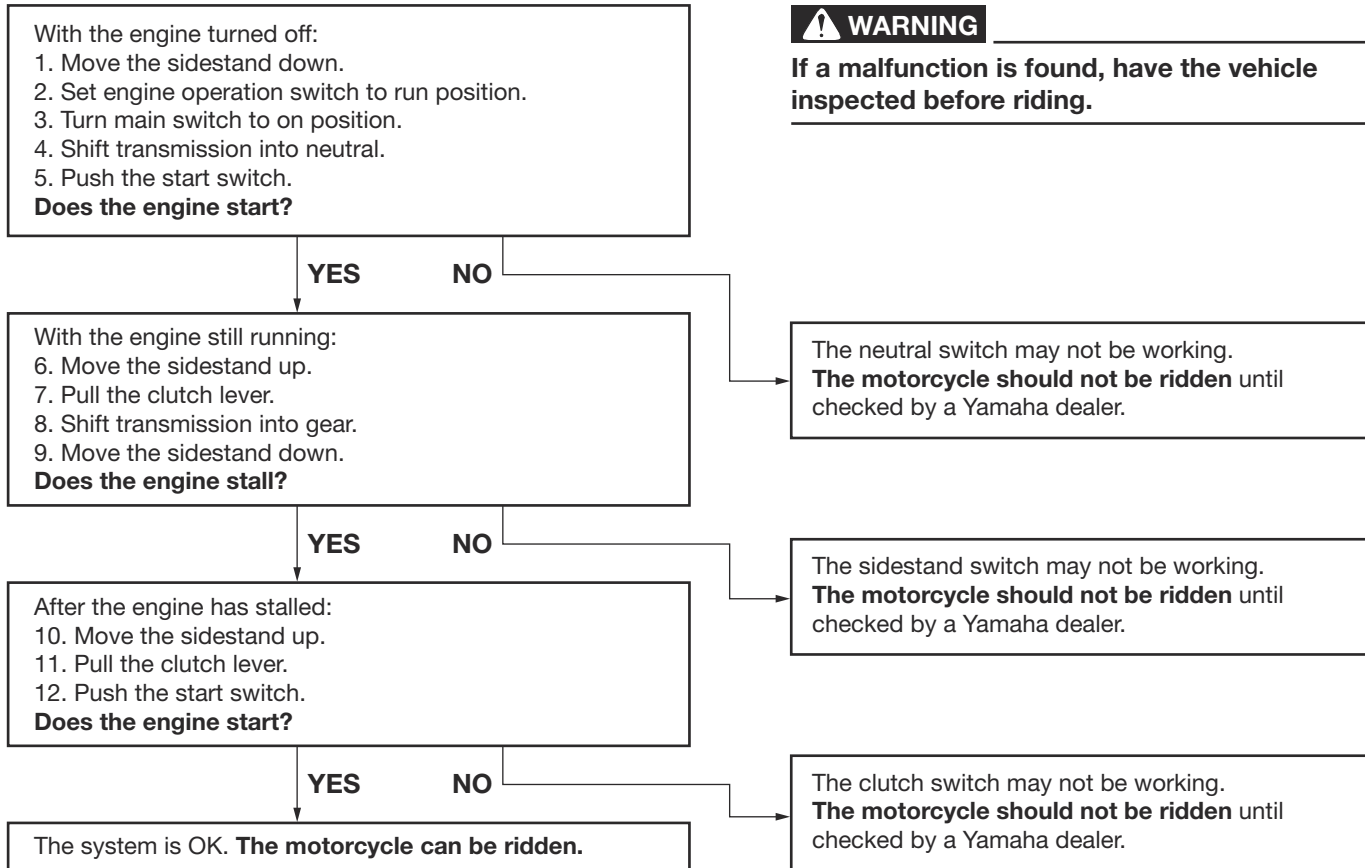

WARNING

If a malfunction is found, have the vehicle inspected before riding.

For your safety – pre-operation checks

EAU1559B

Inspect your vehicle each time you use it to make sure the vehicle is in safe operating condition. Always follow the inspection and maintenance procedures and schedules described in the Owner's Manual.

EWA11152

WARNING

Failure to inspect or maintain the vehicle properly increases the possibility of an accident or equipment damage. Do not operate the vehicle if you find any problem. If a problem cannot be corrected by the procedures provided in this manual, have the vehicle inspected by a Yamaha dealer.

Before using this vehicle, check the following points:

ITEM	CHECKS	PAGE
Fuel	<ul style="list-style-type: none">• Check fuel level in fuel tank.• Refuel if necessary.• Check fuel line for leakage.• Check fuel tank overflow hose for obstructions, cracks or damage, and check hose connection.	6-45, 6-46
Engine oil	<ul style="list-style-type: none">• Check oil level in engine.• If necessary, add recommended oil to specified level.• Check vehicle for oil leakage.	9-11
Coolant	<ul style="list-style-type: none">• Check coolant level in reservoir.• If necessary, add recommended coolant to specified level.• Check cooling system for leakage.	9-14
Front brake	<ul style="list-style-type: none">• Check operation.• If soft or spongy, have Yamaha dealer bleed hydraulic system.• Check brake pads for wear.• Replace if necessary.• Check fluid level in reservoir.• If necessary, add specified brake fluid to specified level.• Check hydraulic system for leakage.	9-21, 9-22

For your safety – pre-operation checks

ITEM	CHECKS	PAGE
Rear brake	<ul style="list-style-type: none"> • Check operation. • If soft or spongy, have Yamaha dealer bleed hydraulic system. • Check brake pads for wear. • Replace if necessary. • Check fluid level in reservoir. • If necessary, add specified brake fluid to specified level. • Check hydraulic system for leakage. 	9-21, 9-22
Clutch	<ul style="list-style-type: none"> • Check operation. • Lubricate cable if necessary. • Check lever free play. • Adjust if necessary. 	9-19
Throttle grip	<ul style="list-style-type: none"> • Check for smooth rotation and automatic return. 	9-27
Control cables	<ul style="list-style-type: none"> • Make sure that operation is smooth. • Lubricate if necessary. 	9-26
Drive chain	<ul style="list-style-type: none"> • Check chain slack. • Adjust if necessary. • Check chain condition. • Lubricate if necessary. 	9-24, 9-26
Wheels and tires	<ul style="list-style-type: none"> • Check for damage. • Check tire condition and tread depth. • Check air pressure. • Correct if necessary. 	9-17, 9-19
Brake and shift pedals	<ul style="list-style-type: none"> • Make sure that operation is smooth. • Lubricate pedal pivoting points if necessary. 	9-27
Brake and clutch levers	<ul style="list-style-type: none"> • Make sure that operation is smooth. • Lubricate lever pivoting points if necessary. 	9-28
Sidestand	<ul style="list-style-type: none"> • Make sure that operation is smooth. • Lubricate pivot if necessary. 	9-28
Chassis fasteners	<ul style="list-style-type: none"> • Make sure that all nuts, bolts and screws are properly tightened. • Tighten if necessary. 	—
Instruments, lights, signals and switches	<ul style="list-style-type: none"> • Check operation. • Correct if necessary. 	—

For your safety – pre-operation checks

ITEM	CHECKS	PAGE
Sidestand switch	<ul style="list-style-type: none">• Check operation of ignition circuit cut-off system.• If system is not working correctly, have Yamaha dealer check vehicle.	6-57

EAU15952

Read the Owner's Manual carefully to become familiar with all controls. If there is a control or function you do not understand, ask your Yamaha dealer.

EWA10272



Failure to familiarize yourself with the controls can lead to loss of control, which could cause an accident or injury.

EAU17094

Engine break-in

There is never a more important period in the life of your engine than the period between 0 and 1600 km (1000 mi). For this reason, you should read the following material carefully.

Since the engine is brand new, do not put an excessive load on it for the first 1600 km (1000 mi). The various parts in the engine wear and polish themselves to the correct operating clearances. During this period, prolonged full-throttle operation or any condition that might result in engine overheating must be avoided.

EAU16842

1000–1600 km (600–1000 mi)

Avoid prolonged operation above 6300 r/min.

1600 km (1000 mi) and beyond

The vehicle can now be operated normally.

ECA10311

NOTICE

- Keep the engine speed out of the tachometer red zone.
- If any engine trouble should occur during the engine break-in period, immediately have a Yamaha dealer check the vehicle.

EAU17094

0–1000 km (0–600 mi)

Avoid prolonged operation above 5300 r/min. **NOTICE: After 1000 km (600 mi) of operation, the engine oil must be changed and the oil filter cartridge or element replaced.**^[ECA10303]

Operation and important riding points

Starting the engine

EUA9131

The ignition circuit cut-off system will enable starting when:

- the transmission is in the neutral position or
- the transmission is in gear, the sidestand is up, and the clutch lever is pulled.

To start the engine:

1. Turn the main switch on and set the engine operation switch to the run position. (See page 6-3.)

TIP

For smart key equipped models: the smart key must be turned on and in range.

2. Confirm the appropriate display indicator(s) and meter indicator/warning light(s) come on, go off, and otherwise function as specified in this manual.
 - See page 6-5 for information about meter indicator and warning lights.
 - See page 6-16 for information about display indicators.

TIP

- Do not start the engine if any indicator or warning remains on, except for the oil pressure warning.
- The oil pressure warning should come on and stay on until the engine is started. After the engine is started, it should go off.
- If the oil pressure warning does not come on and stay on, do not start the engine.

ECA29080

NOTICE

If an indicator or warning is signaling a problem or abnormal condition, then stop all vehicle operation immediately. Have a Yamaha dealer inspect the vehicle.

3. Shift the transmission into the neutral position.
4. Start the engine by pushing the start switch.
5. Release the start switch when the engine starts, or after 5 seconds. Wait 10 seconds before pressing the switch again to allow battery voltage to restore.

TIP

- If the engine fails to start, try again with and the throttle grip turned by a 1/4 turn (20 degrees) open.

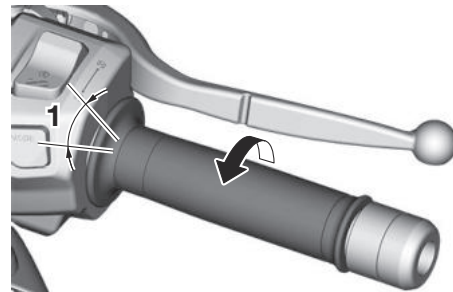

1. 1/4 turn (20 degrees)

ECA11043

NOTICE

For maximum engine life, never accelerate hard when the engine is cold!

EAU68221

EAU0073

EAU91544

TIP

This model is equipped with:

- an inertial measurement unit (IMU). This unit stops the engine in case of a turnover. Turn the main switch off and then on before attempting to restart the engine. Failing to do so will prevent the engine from starting even though the engine will crank when pushing the start switch.
- an engine auto-stop system. The engine stops automatically if left idling for 20 minutes. If the engine stops, simply push the start switch to restart the engine.

NOTICE

Do not ride through deep water, otherwise the engine may be damaged. Avoid puddles because they may be deeper than expected.

ECAN0072

Shifting

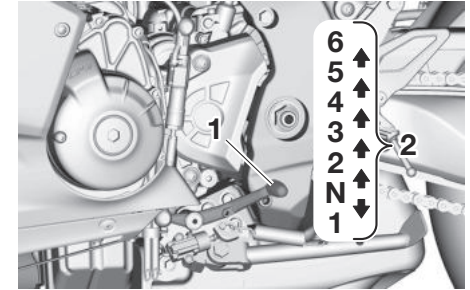

1. Shift pedal
2. Gear positions

Shifting gears lets you control the amount of engine power available for starting off, accelerating, climbing hills, etc. The gear positions are shown in the illustration.

TIP

- To shift the transmission into the neutral position (N), press the shift pedal down repeatedly until it reaches the end of its travel, and then slightly raise it.
- This model is equipped with a quick shifter. (See page 4-3.)

Operation and important riding points

ECA22523

NOTICE

- When shifting, press the shift pedal firmly until you feel the gear shift is complete.
- Even with the transmission in the neutral position, do not coast for long periods of time with the engine off, nor tow the motorcycle for long distances. The transmission is properly lubricated only when the engine is running. Inadequate lubrication may damage the transmission.
- Except when using the quick shifter, always pull the clutch lever when changing gears to avoid damaging the engine, transmission, and drivetrain.

EAU85370

To start out and accelerate

1. Pull the clutch lever to disengage the clutch.
2. Shift the transmission into first gear. The neutral indicator light should go out.

3. Open the throttle gradually, and at the same time, release the clutch lever slowly.
4. After starting out, close the throttle, and at the same time, quickly pull the clutch lever in.
5. Shift the transmission into second gear. (Make sure not to shift the transmission into the neutral position.)
6. Open the throttle part way and gradually release the clutch lever.
7. Follow the same procedure when shifting to the next higher gear.

EAU85380

To decelerate

1. Release the throttle and apply both the front and the rear brakes smoothly to slow the motorcycle.
2. As the vehicle decelerates, shift to a lower gear.
3. When the engine is about to stall or runs roughly, pull the clutch lever in, use the brakes to slow the motorcycle, and continue to downshift as necessary.
4. Once the motorcycle has stopped, the transmission can be shifted

into the neutral position. The neutral indicator light should come on and then the clutch lever can be released.

EWA17380

WARNING

- Improper braking can cause loss of control or traction. Always use both brakes and apply them smoothly.
- Make sure that the motorcycle and the engine have sufficiently slowed before shifting to a lower gear. Engaging a lower gear when the vehicle or engine speed is too high could make the rear wheel lose traction or the engine to over-rev. This could cause loss of control, an accident and injury. It could also cause engine or drive train damage.

EAU16811

Tips for reducing fuel consumption

Fuel consumption depends largely on your riding style. Consider the following tips to reduce fuel consumption:

- Shift up swiftly, and avoid high engine speeds during acceleration.
- Do not rev the engine while shifting down, and avoid high engine speeds with no load on the engine.
- Turn the engine off instead of letting it idle for an extended length of time (e.g., in traffic jams, at traffic lights or at railroad crossings).

EAU17214

Parking

When parking, stop the engine, and then remove the key from the main switch.

EWA10312

WARNING

- **Since the engine and exhaust system can become very hot, park in a place where pedestrians or children are not likely to touch them and be burned.**
 - **Do not park on a slope or on soft ground, otherwise the vehicle may overturn, increasing the risk of a fuel leak and fire.**
 - **Do not park near grass or other flammable materials which might catch fire.**
-

Periodic maintenance and adjustment

EAU17246

Periodic inspection, adjustment, and lubrication will keep your vehicle in the safest and most efficient condition possible. Safety is an obligation of the vehicle owner/operator. The most important points of vehicle inspection, adjustment, and lubrication are explained on the following pages.

The intervals given in the periodic maintenance charts should be simply considered as a general guide under normal riding conditions. However, depending on the weather, terrain, geographical location, and individual use, the maintenance intervals may need to be shortened.

EWA10322

WARNING

Failure to properly maintain the vehicle or performing maintenance activities incorrectly may increase your risk of injury or death during service or while using the vehicle. If you are not familiar with vehicle service, have a Yamaha dealer perform service.

EWA15123

WARNING

Turn off the engine when performing maintenance unless otherwise specified.

- **A running engine has moving parts that can catch on body parts or clothing and electrical parts that can cause shocks or fires.**
- **Running the engine while servicing can lead to eye injury, burns, fire, or carbon monoxide poisoning – possibly leading to death. See page 2-2 for more information about carbon monoxide.**

EWA15461

WARNING

Brake discs, calipers, drums, and linings can become very hot during use. To avoid possible burns, let brake components cool before touching them.

EAU17303

Emission controls not only function to ensure cleaner air, but are also vital to proper engine operation and maximum performance. In the following periodic maintenance charts, the services related to emissions control are grouped separately. These services require specialized data, knowledge, and equipment. Maintenance, replacement, or repair of the emission control devices and systems may be performed by any repair establishment or individual that is certified (if applicable). Yamaha dealers are trained and equipped to perform these particular services.

EAUJA2830

Tool kit

The tool kit should be stored separately from the vehicle. However, be sure to put a hexagon wrench in the pouch and store it in the location shown.

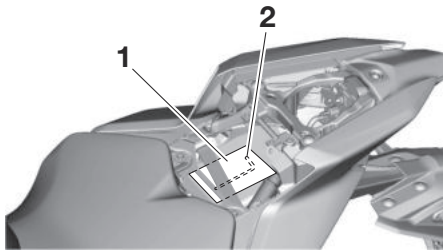

1. Storage pouch
2. Hexagon wrench

The information included in this manual and the tools provided are intended to assist you in the performance of preventive maintenance and minor repairs. However, a torque wrench and other tools are necessary to perform certain maintenance work correctly.

TIP

If you do not have the tools or experience required for a particular job, have your Yamaha dealer perform it for you.

Periodic maintenance and adjustment

EAU91891

TIP

- The annual checks must be performed every year, except if a kilometer-based maintenance is performed instead.
- For 31000 km or 30 months, repeat the maintenance intervals starting from 7000 km or 6 months.
- Items marked with an asterisk require special tools, data and technical skills, have a Yamaha dealer perform the service.

EAU91902

Periodic maintenance chart for the emission control system

No.	ITEM	ROUTINE	INITIAL	ODOMETER READINGS					ANNUAL CHECK
			1000 km or 1 month	7000 km or 6 months	13000 km or 12 months	19000 km or 18 months	25000 km or 24 months		
1	* Fuel line	<ul style="list-style-type: none"> • Check fuel hoses for cracks or damage. • Replace if necessary. 		√	√	√	√	√	
2	* Spark plugs	<ul style="list-style-type: none"> • Check condition. • Adjust gap and clean. • Replace. 		√					
			Every 19000 km (12000 mi) or 18 months						
3	* Valve clearance	<ul style="list-style-type: none"> • Check and adjust valve clearance when engine is cold. 	Every 42000 km (26600 mi)						
4	* Fuel injection	<ul style="list-style-type: none"> • Check engine idle speed. • Check and adjust synchronization. 	√	√	√	√	√	√	
5	* Exhaust system	<ul style="list-style-type: none"> • Check for leakage. • Tighten if necessary. • Replace gasket(s) if necessary. 	√	√	√	√	√		
6	* Evaporative emission control system	<ul style="list-style-type: none"> • Check control system for damage. • Replace if necessary. 			√		√		

Periodic maintenance and adjustment

EAU92131

General maintenance and lubrication chart

No.	ITEM	ROUTINE	INITIAL	ODOMETER READINGS					ANNUAL CHECK
			1000 km or 1 month	7000 km or 6 months	13000 km or 12 months	19000 km or 18 months	25000 km or 24 months		
1	* Diagnostic system check	<ul style="list-style-type: none"> Perform dynamic inspection using Yamaha diagnostic tool. Check the error codes. 	√	√	√	√	√	√	
2	* Air filter element	<ul style="list-style-type: none"> Replace. 	Every 40000 km (24000 mi)						
3	Clutch	<ul style="list-style-type: none"> Check operation. Adjust. 	√	√	√	√	√		
4	* Front brake	<ul style="list-style-type: none"> Check operation, fluid level, and for fluid leakage. Replace brake pads if necessary. 	√	√	√	√	√	√	
5	* Rear brake	<ul style="list-style-type: none"> Check operation, fluid level, and for fluid leakage. Replace brake pads if necessary. 	√	√	√	√	√	√	
6	* Brake hoses	<ul style="list-style-type: none"> Check for cracks or damage. Check for correct routing and clamping. 		√	√	√	√	√	
		<ul style="list-style-type: none"> Replace. 	Every 4 years						
7	* Brake fluid	<ul style="list-style-type: none"> Change. 	Every 2 years						
8	* Wheels	<ul style="list-style-type: none"> Check runout and for damage. Replace if necessary. 		√	√	√	√		
9	* Tires	<ul style="list-style-type: none"> Check tread depth and for damage. Replace if necessary. Check air pressure. Correct if necessary. 		√	√	√	√	√	
10	* Wheel bearings	<ul style="list-style-type: none"> Check bearings for looseness or damage. 		√	√	√	√		

Periodic maintenance and adjustment

No.	ITEM	ROUTINE	INITIAL	ODOMETER READINGS					ANNUAL CHECK
			1000 km or 1 month	7000 km or 6 months	13000 km or 12 months	19000 km or 18 months	25000 km or 24 months		
11	* Swingarm pivot bearings	<ul style="list-style-type: none"> Check operation and for excessive play. 		√	√	√	√		
		<ul style="list-style-type: none"> Lubricate with lithium-soap-based grease. 	Every 50000 km (30000 mi)						
12	Drive chain	<ul style="list-style-type: none"> Check chain slack, alignment and condition. Adjust and lubricate chain with a special O-ring chain lubricant thoroughly. 	Every 1000 km (600 mi) and after washing the motorcycle, riding in the rain or riding in wet areas						
13	* Steering bearings	<ul style="list-style-type: none"> Check bearing assemblies for looseness. 	√	√	√	√	√		
		<ul style="list-style-type: none"> Moderately repack with lithium-soap-based grease. 	Every 19000 km (12000 mi)						
14	* Chassis fasteners	<ul style="list-style-type: none"> Make sure that all nuts, bolts and screws are properly tightened. 		√	√	√	√	√	
15	Brake lever pivot shaft	<ul style="list-style-type: none"> Lubricate with silicone grease. 		√	√	√	√	√	
16	Brake pedal pivot shaft	<ul style="list-style-type: none"> Lubricate with lithium-soap-based grease. 		√	√	√	√	√	
17	Clutch lever pivot shaft	<ul style="list-style-type: none"> Lubricate with lithium-soap-based grease. 		√	√	√	√	√	
18	Shift pedal pivot shaft	<ul style="list-style-type: none"> Lubricate with lithium-soap-based grease. 		√	√	√	√	√	
19	Sidestand	<ul style="list-style-type: none"> Check operation. Lubricate with molybdenum disulfide grease. 		√	√	√	√	√	
20	* Sidestand switch	<ul style="list-style-type: none"> Check operation and replace if necessary. 	√	√	√	√	√	√	

Periodic maintenance and adjustment

No.	ITEM	ROUTINE	INITIAL	ODOMETER READINGS					ANNUAL CHECK
			1000 km or 1 month	7000 km or 6 months	13000 km or 12 months	19000 km or 18 months	25000 km or 24 months		
21	* Front fork	<ul style="list-style-type: none"> • Check operation and for oil leakage. • Replace if necessary. 		√	√	√	√		
22	* Shock absorber assembly	<ul style="list-style-type: none"> • Check operation and for oil leakage. • Replace if necessary. 		√	√	√	√		
23	* Rear suspension relay arm and connecting arm pivoting points	<ul style="list-style-type: none"> • Check operation. 		√	√	√	√		
24	Engine oil	<ul style="list-style-type: none"> • Change. • Check oil level and vehicle for oil leakage. 	√	√	√	√	√	√	
25	Engine oil filter cartridge	<ul style="list-style-type: none"> • Replace. 	√		√		√		
26	* Cooling system	<ul style="list-style-type: none"> • Check coolant level and vehicle for coolant leakage. 		√	√	√	√	√	
		<ul style="list-style-type: none"> • Change with Yamaha genuine coolant. 	Every 3 years						
27	* Front and rear brake switches	<ul style="list-style-type: none"> • Check operation. 	√	√	√	√	√	√	
28	Control cables	<ul style="list-style-type: none"> • Apply Yamaha cable lubricant or other suitable cable lubricant thoroughly. 		√	√	√	√	√	
29	* Throttle grip	<ul style="list-style-type: none"> • Check operation. • Lubricate throttle grip housing tube guides. 		√	√	√	√	√	
30	* Lights, signals and switches	<ul style="list-style-type: none"> • Check operation. • Adjust headlight beam. 	√	√	√	√	√	√	

Periodic maintenance and adjustment

EAU18681

TIP

- Air filter
 - This model's air filter is equipped with a disposable oil-coated paper element, which must not be cleaned with compressed air to avoid damaging it.
 - The air filter element needs to be replaced more frequently when riding in unusually wet or dusty areas.
 - Hydraulic brake service
 - Regularly check and, if necessary, correct the brake fluid level.
 - Every two years replace the internal components of the brake master cylinders and calipers, and change the brake fluid.
 - Replace the brake hoses every four years and if cracked or damaged.
-

Removing and installing cowlings

EAU18782

The cowlings shown need to be removed to perform some of the maintenance jobs described in this chapter. Refer to this section each time a cowling needs to be removed and installed.

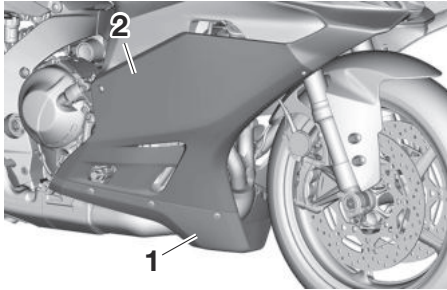

1. Cowling A
2. Cowling B

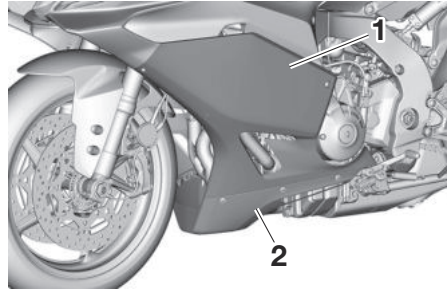

1. Cowling C
2. Cowling A

Cowling A

To remove the cowling

Remove the bolts on both sides, and then pull the cowling off as shown.

EAU5401

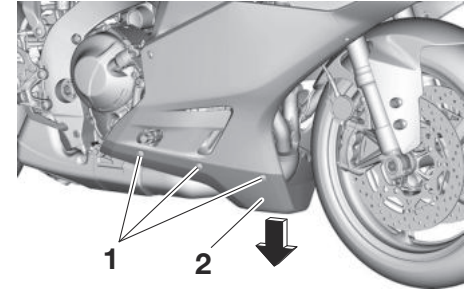

1. Bolt
2. Cowling A

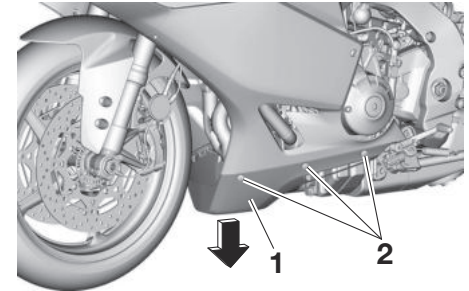

1. Cowling A
2. Bolt

To install the cowling

Place the cowling in its original position, and then install the bolts on both sides.

Periodic maintenance and adjustment

Cowling B and C

To remove the cowlings

1. Remove cowling A.
2. Remove the quick fasteners, bolts and washers from the cowling to be removed, and pull the cowling off as shown.

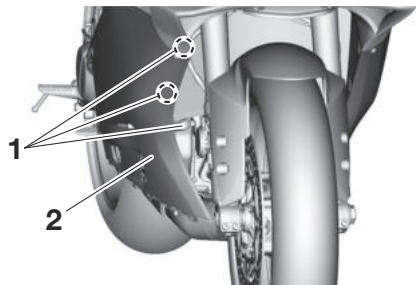

1. Quick fastener
2. Cowling B

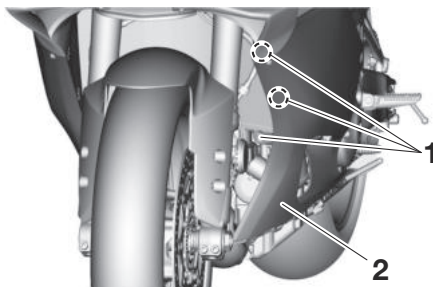

1. Quick fastener
2. Cowling C

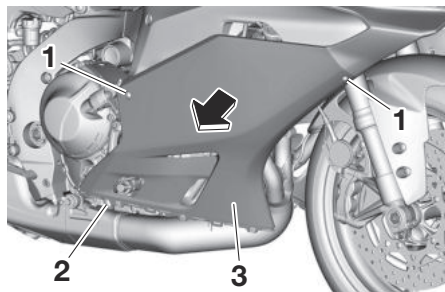

1. Bolt and washer
2. Bolt
3. Cowling B

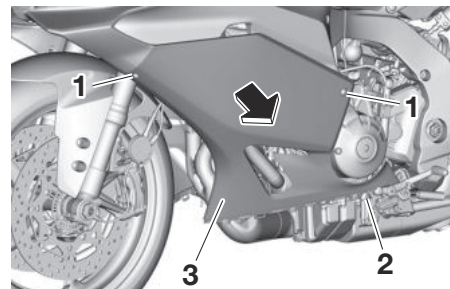

1. Bolt and washer
2. Bolt
3. Cowling C

To install the cowlings

1. Fit the upper projections into the slots, and then place the cowling in its original position.

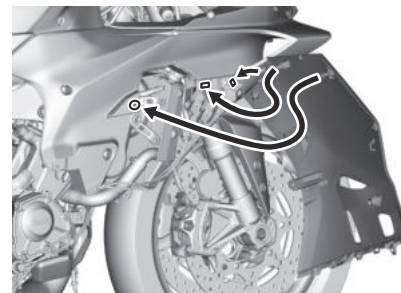

Periodic maintenance and adjustment

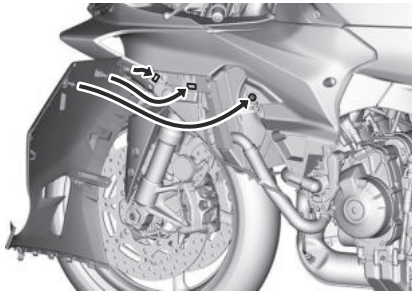

2. Install the quick fasteners, bolts and washers.
3. Install cowling A.

Checking the spark plugs

EAU19653

The spark plugs are important engine components, which should be checked periodically, preferably by a Yamaha dealer. Since heat and deposits will cause any spark plug to slowly erode, they should be removed and checked in accordance with the periodic maintenance and lubrication chart. In addition, the condition of the spark plugs can reveal the condition of the engine.

The porcelain insulator around the center electrode of each spark plug should be a medium-to-light tan (the ideal color when the vehicle is ridden normally), and all spark plugs installed in the engine should have the same color. If any spark plug shows a distinctly different color, the engine could be operating improperly. Do not attempt to diagnose such problems yourself. Instead, have a Yamaha dealer check the vehicle.

If a spark plug shows signs of electrode erosion and excessive carbon or other deposits, it should be replaced.

Specified spark plug:
NGK/LMAR9A-9

Before installing a spark plug, the spark plug gap should be measured with a wire thickness gauge and, if necessary, adjusted to specification.

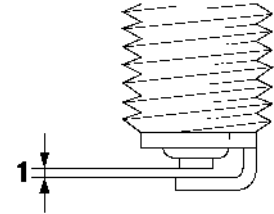

1. Spark plug gap

Spark plug gap:

0.8–0.9 mm (0.031–0.035 in)

Clean the surface of the spark plug gasket and its mating surface, and then wipe off any grime from the spark plug threads.

Tightening torque:

Spark plug:

13 N·m (1.3 kgf·m, 9.6 lb·ft)

Periodic maintenance and adjustment

TIP

If a torque wrench is not available when installing a spark plug, a good estimate of the correct torque is 1/4–1/2 turn past finger tight. However, the spark plug should be tightened to the specified torque as soon as possible.

ECA10841

NOTICE

Do not use any tools to remove or install the spark plug cap, otherwise the ignition coil coupler may get damaged. The spark plug cap may be difficult to remove because the rubber seal on the end of the cap fits tightly. To remove the spark plug cap, simply twist it back and forth while pulling it out; to install it, twist it back and forth while pushing it in.

9

Canister

EAU36114

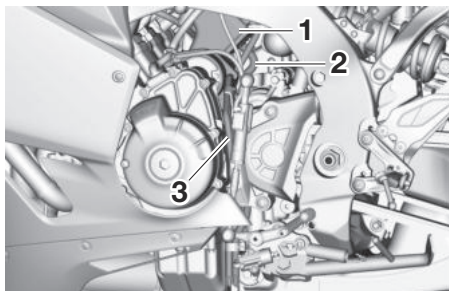

1. Canister
2. Canister breather hose
3. Fuel tank overflow hose

This model is equipped with a canister to prevent the discharging of fuel vapor into the atmosphere. Before operating this vehicle, make sure to check the following:

- Check each hose connection.
- Check each hose and canister for cracks or damage. Replace if damaged.
- Make sure that the canister breather is not blocked, and if necessary, clean it.

EAU1991A

Engine oil

The engine oil level should be checked regularly. In addition, the oil must be changed and the oil filter cartridge replaced at the intervals specified in the periodic maintenance chart.

Recommended engine oil:

See page 11-1.

Oil quantity:

Oil change:

2.80 L (2.96 US qt, 2.46 Imp.qt)

With oil filter removal:

3.20 L (3.38 US qt, 2.82 Imp.qt)

ECA11621

NOTICE

- In order to prevent clutch slippage (since the engine oil also lubricates the clutch), do not mix any chemical additives. Do not use oils with a diesel specification of “CD” or oils of a higher quality than specified. In addition, do not use oils labeled “ENERGY CONSERVING II” or higher.
- Make sure that no foreign material enters the crankcase.

Periodic maintenance and adjustment

To check the engine oil level

1. Place the vehicle on a level surface and hold it in an upright position. A slight tilt to the side can result in a false reading.
2. Start the engine, warm it up for several minutes, and then turn it off.
3. Wait a few minutes for the oil level to settle for an accurate reading, and then check the oil level through the engine oil level check window located at the bottom-right side of the crankcase.

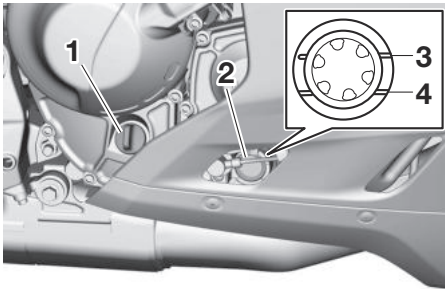

1. Engine oil filler cap
2. Engine oil level check window
3. Maximum level mark
4. Minimum level mark

TIP

The engine oil should be between the minimum and maximum level marks.

4. If the engine oil is below the minimum level mark, add sufficient oil of the recommended type to raise it to the correct level.

TIP

Check the O-ring for damage, and replace it if necessary.

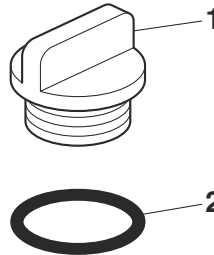

1. Engine oil filler cap
2. O-ring

To change the engine oil (and filter)

1. Start the engine and allow it to idle for a few minutes to warm up the oil, and then stop the engine.

2. Place an oil pan under the engine to collect the used oil.
3. Remove cowling C. (See page 9-8.)
4. Remove the engine oil filler cap, and then the engine oil drain bolt and gasket.

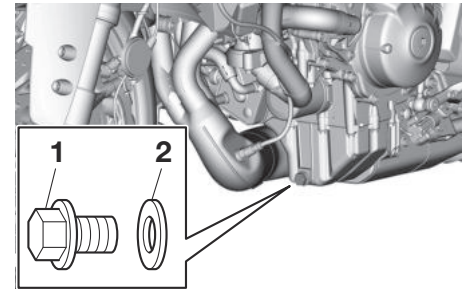

1. Engine oil drain bolt
2. Gasket

TIP

Skip steps 5-7 if the oil filter cartridge is not being replaced.

5. Remove the oil filter cartridge with an oil filter wrench.

Periodic maintenance and adjustment

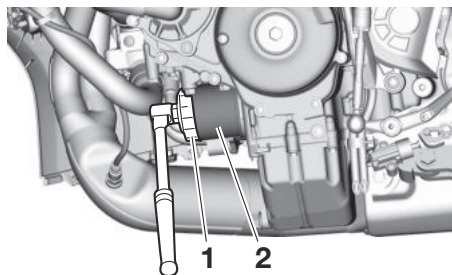

1. Oil filter wrench
2. Oil filter cartridge

TIP

An oil filter wrench is available at a Yamaha dealer.

6. Apply a thin coat of clean engine oil to the O-ring of the new oil filter cartridge.

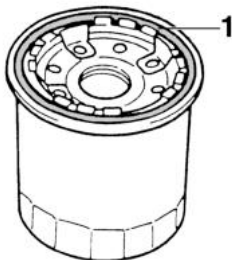

1. O-ring

TIP

Make sure that the O-ring is properly seated.

7. Install the new oil filter cartridge, and then tighten to the specified torque.

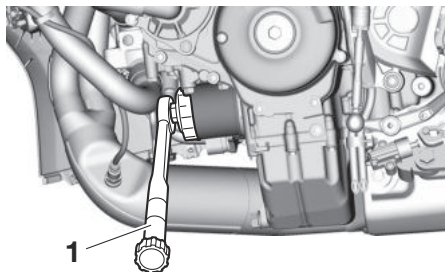

1. Torque wrench

Tightening torque:

Oil filter cartridge:
17 N·m (1.7 kgf·m, 13 lb·ft)

8. Install the engine oil drain bolt with a new gasket, and then tighten the bolt to the specified torque.

Tightening torque:

Engine oil drain bolt:
43 N·m (4.3 kgf·m, 32 lb·ft)

9. Pour the specified amount of the recommended oil into the crankcase.

TIP

Using a funnel is recommended.

10. After checking the engine oil filler cap O-ring, install the filler cap.

TIP

Wipe off any spilled oil before starting the engine.

11. Start the engine and let it idle while checking for oil leaks.

TIP

If any oil leaks are found which you cannot fix, have the vehicle inspected.

12. Stop the engine, wait a few minutes for the oil level to settle, and then check the oil level one last time. **NOTICE: Do not operate the vehicle until you know that the engine oil level is sufficient.**

[ECA10012]

13. Install the cowling.

Why Yamalube

EAU85450

YAMALUBE oil is a Genuine YAMAHA Part born of the engineers' passion and belief that engine oil is an important liquid engine component. We form teams of specialists in the fields of mechanical engineering, chemistry, electronics and track testing, and have them develop the engine together with the oil it will use. Yamalube oils take full advantage of the base oil's qualities and blend in the ideal balance of additives to make sure the final oil clears our performance standards. Thus, Yamalube mineral, semisynthetic and synthetic oils have their own distinct characters and value. Yamaha's experience gained over many years of research and development into oil since the 1960's helps make Yamalube the best choice for your Yamaha engine.



Coolant

EAU84230

The coolant level should be checked regularly. In addition, the coolant must be changed at the intervals specified in the periodic maintenance chart.

Recommended coolant:

YAMAHA GENUINE COOLANT

Coolant quantity:

Coolant reservoir (max level mark):
0.28 L (0.30 US qt, 0.25 Imp.qt)
Radiator (including all routes):
1.78 L (1.88 US qt, 1.57 Imp.qt)

TIP

If genuine Yamaha coolant is not available, use an ethylene glycol antifreeze containing corrosion inhibitors for aluminum engines and mix with distilled water at a 1:1 ratio.

EAU66512

To check the coolant level

Since the coolant level varies with engine temperature, check when the engine is cold.

1. Park the vehicle on a level surface.

Periodic maintenance and adjustment

2. With the vehicle in an upright position, look at the coolant level in the reservoir.

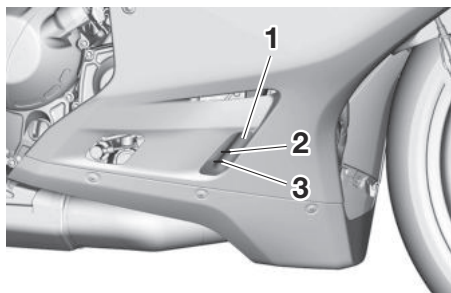

1. Coolant reservoir
2. Maximum level mark
3. Minimum level mark

3. If the coolant is at or below the minimum level mark, remove cowling B to access the coolant reservoir. (See page 9-8.)
4. Remove the coolant reservoir cap.
WARNING! Remove only the coolant reservoir cap. Never attempt to remove the radiator cap when the engine is hot.

[EWA15162]

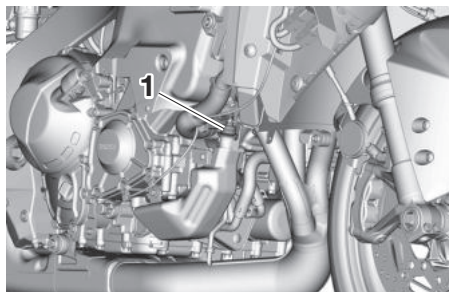

1. Coolant reservoir cap

5. Add coolant to the maximum level mark. **NOTICE: If coolant is not available, use distilled water or soft tap water instead. Do not use hard water or salt water since it is harmful to the engine. If water has been used instead of coolant, replace it with coolant as soon as possible, otherwise the cooling system will not be protected against frost and corrosion. If water has been added to the coolant, have a Yamaha dealer check the anti-freeze content of the coolant as soon as possible, otherwise the effectiveness of the coolant will be reduced.**[ECA10473]

6. Install the coolant reservoir cap.
7. Install the cowling.

EAU33032

Changing the coolant

The coolant must be changed at the intervals specified in the periodic maintenance and lubrication chart. Have a Yamaha dealer change the coolant. **WARNING! Never attempt to remove the radiator cap when the engine is hot.**[EWA10382]

Air filter element

EAU36765

The air filter element must be replaced at the intervals specified in the periodic maintenance and lubrication chart. Have a Yamaha dealer replace the air filter element.

Checking the engine idling speed

EAU44735

Check the engine idling speed and, if necessary, have it corrected by a Yamaha dealer.

Engine idling speed:
1200–1400 r/min

Valve clearance

EAU21403

The valves are an important engine component, and since valve clearance changes with use, they must be checked and adjusted at the intervals specified in the periodic maintenance chart. Unadjusted valves can result in improper air-fuel mixture, engine noise, and eventually engine damage. To prevent this from occurring, have your Yamaha dealer check and adjust the valve clearance at regular intervals.

TIP

This service must be performed when the engine is cold.

Periodic maintenance and adjustment

Tires

EAUA7801

Tires are the only contact between the vehicle and the road. Safety in all conditions of riding depends on a relatively small area of road contact. Therefore, it is essential to maintain the tires in good condition at all times and replace them at the appropriate time with the specified tires.

Tire air pressure

The tire air pressure should be checked and, if necessary, adjusted before each ride.

EWA10504

WARNING

Operation of this vehicle with improper tire pressure may cause severe injury or death from loss of control.

- The tire air pressure must be checked and adjusted on cold tires (i.e., when the temperature of the tires equals the ambient temperature).
- The tire air pressure must be adjusted in accordance with the riding speed and with the total

weight of rider, passenger, cargo, and accessories approved for this model.

Cold tire air pressure:

1 person:

Front:

250 kPa (2.50 kgf/cm², 36 psi)

Rear:

250 kPa (2.50 kgf/cm², 36 psi)

2 persons:

Front:

250 kPa (2.50 kgf/cm², 36 psi)

Rear:

250 kPa (2.50 kgf/cm², 36 psi)

Maximum load:

Vehicle:

164 kg (363 lb)

The vehicle's maximum load is the combined weight of the rider, passenger, cargo, and any accessories.

EWA10512

WARNING

Never overload your vehicle. Operation of an overloaded vehicle could cause an accident.

Tire inspection

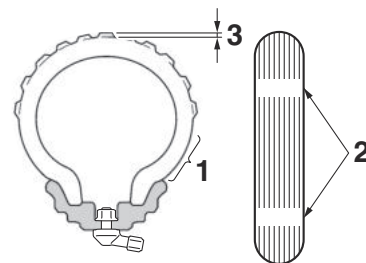

1. Tire sidewall
2. Tire wear indicator
3. Tire tread depth

The tires must be checked before each ride. If the tire shows crosswise lines (minimum tread depth), if the tire has a nail or glass fragments in it, or if the sidewall is cracked, have a Yamaha dealer replace the tire immediately.

Minimum tire tread depth (front and rear):

1.0 mm (0.04 in)

EWA10472

WARNING

- Have a Yamaha dealer replace excessively worn tires. Besides

Periodic maintenance and adjustment

being illegal, operating the vehicle with excessively worn tires decreases riding stability and can lead to loss of control.

- The replacement of all wheel and brake-related parts, including the tires, should be left to a Yamaha dealer, who has the necessary professional knowledge and experience to do so.
- Ride at moderate speeds after changing a tire since the tire surface must first be “broken in” for it to develop its optimal characteristics.

Tire information

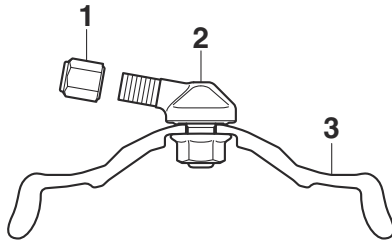

1. Tire air valve cap with seal

2. Clamp-in valve
3. Wheel rim

This model is equipped with tubeless tires and tire air valves.

Tires age, even if they have not been used or have only been used occasionally. Cracking of the tread and sidewall rubber, sometimes accompanied by carcass deformation, is an evidence of ageing. Old and aged tires shall be checked by tire specialists to ascertain their suitability for further use.

EWA22011

⚠ WARNING

- The front and rear tires should be of the same make and design, otherwise the handling characteristics of the motorcycle may be different, which could lead to an accident.
- Always make sure that the valve caps are securely installed to prevent air pressure leakage.
- Use only the specified tire valves and valve cores to avoid tire deflation while high-speed riding.
- The tire air valve original position is with the valve cap point-

ing to the right side of the vehicle, perpendicular (90 degree right angle) to the axis (center line) of the wheel. If the tire air valve becomes misaligned, do not twist it back to its original position by yourself. Otherwise, leakage may occur. Have a Yamaha dealer inspect the valve.

After extensive tests, only the tires listed below have been approved for this model by Yamaha.

Front tire:

Size:

120/70ZR17M/C(58W)

Manufacturer/model:

BRIDGESTONE/BATTLAX RACING STREET RS11F

Rear tire:

Size:

180/55ZR17M/C(73W)

Manufacturer/model:

BRIDGESTONE/BATTLAX RACING STREET RS11R

Periodic maintenance and adjustment

EWA10601

EAU21963

EAU55645

WARNING

This motorcycle is fitted with super-high-speed tires. Note the following points in order to make the most efficient use of these tires.

- Use only the specified replacement tires. Other tires may run the danger of bursting at super high speeds.
- Brand-new tires can have a relatively poor grip on certain road surfaces until they have been “broken in”. Therefore, it is advisable before doing any high-speed riding to ride conservatively for approximately 100 km (60 mi) after installing a new tire.
- The tires must be warmed up before a high-speed run.
- Always adjust the tire air pressure according to the operating conditions.

Cast wheels

To maximize the performance, durability, and safe operation of your vehicle, note the following points regarding the specified wheels.

- The wheel rims should be checked for cracks, bends, warp or other damage before each ride. If any damage is found, have a Yamaha dealer replace the wheel. Do not attempt even the smallest repair to the wheel. A deformed or cracked wheel must be replaced.
- The wheel should be balanced whenever either the tire or wheel has been changed or replaced. An unbalanced wheel can result in poor performance, adverse handling characteristics, and a shortened tire life.

Adjusting the clutch lever free play

Measure the clutch lever free play as shown.

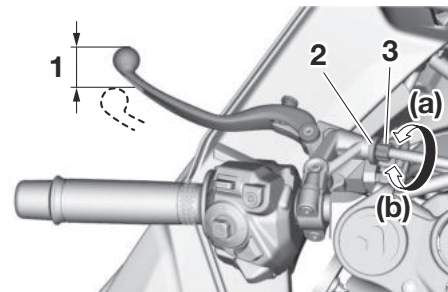

1. Clutch lever free play
2. Locknut (clutch lever)
3. Clutch lever free play adjusting bolt

Clutch lever free play:

5.0–10.0 mm (0.20–0.39 in)

Periodically check the clutch lever free play and, if necessary, adjust it as follows.

1. Loosen the locknut at the clutch lever.
2. To increase the clutch lever free play, turn the clutch lever free play adjusting bolt in direction (a). To

Periodic maintenance and adjustment

decrease the clutch lever free play, turn the adjusting bolt in direction (b).

TIP

If the specified clutch lever free play could be obtained as described above, skip steps 3–6.

3. Fully turn the adjusting bolt at the clutch lever in direction (a) to loosen the clutch cable.
4. Loosen the locknut at the crankcase.

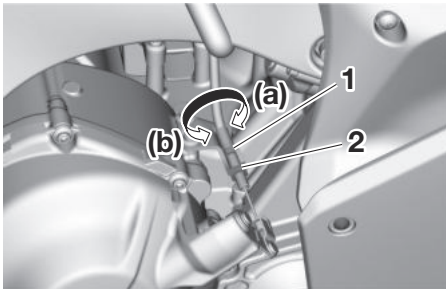

1. Clutch lever free play adjusting nut
 2. Locknut (crankcase)
5. To increase the clutch lever free play, turn the clutch lever free play adjusting nut in direction (a). To

decrease the clutch lever free play, turn the adjusting nut in direction (b).

6. Tighten the locknut at the crankcase.
7. Tighten the locknut at the clutch lever.

Checking the brake lever free play

EAU37914

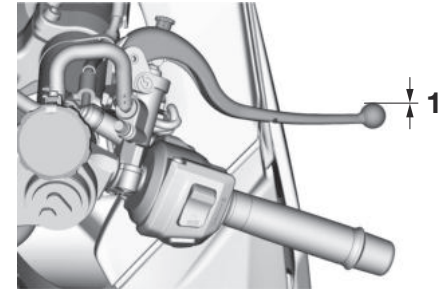

1. No brake lever free play

There should be no free play at the brake lever end. If there is free play, have a Yamaha dealer inspect the brake system.

EWA14212

⚠ WARNING

A soft or spongy feeling in the brake lever can indicate the presence of air in the hydraulic system. If there is air in the hydraulic system, have a Yamaha dealer bleed the system before operating the vehicle. Air in the hydraulic system will diminish the

Periodic maintenance and adjustment

braking performance, which may result in loss of control and an accident.

Brake light switches

EAU36505

The brake light should come on just before braking takes effect. The brake light is activated by switches connected to the brake lever and brake pedal. Since the brake light switches are components of the anti-lock brake system, they should only be serviced by a Yamaha dealer.

Checking the front and rear brake pads

EAU22393

The front and rear brake pads must be checked for wear at the intervals specified in the periodic maintenance and lubrication chart.

Front brake pads

EAU22434

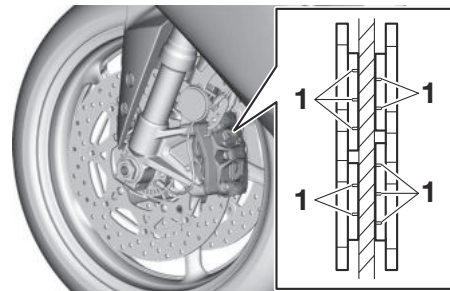

1. Brake pad wear indicator groove

Each front brake pad is provided with wear indicator grooves, which allow you to check the brake pad wear without having to disassemble the brake. To check the brake pad wear, check the wear indicator grooves. If a brake pad has worn to the point that the wear indicator grooves have almost

Periodic maintenance and adjustment

disappeared, have a Yamaha dealer replace the brake pads as a set.

Rear brake pads

EAU46292

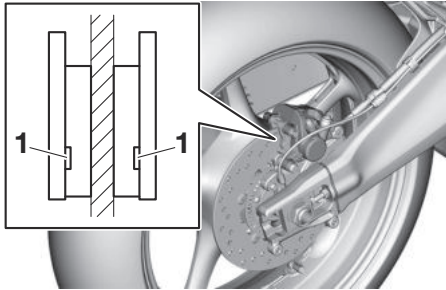

1. Brake pad wear indicator groove

Each rear brake pad is provided with wear indicator grooves, which allow you to check the brake pad wear without having to disassemble the brake. To check the brake pad wear, check the wear indicator grooves. If a brake pad has worn to the point that a wear indicator groove almost appears, have a Yamaha dealer replace the brake pads as a set.

Checking the brake fluid level

EAU66670

Before riding, check that the brake fluid is above the minimum level mark. Check the brake fluid level with the top of the reservoir level. Replenish the brake fluid if necessary.

Front brake

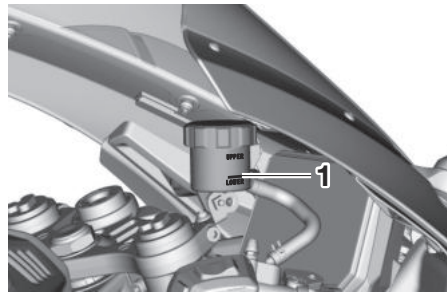

1. Minimum level mark

Rear brake

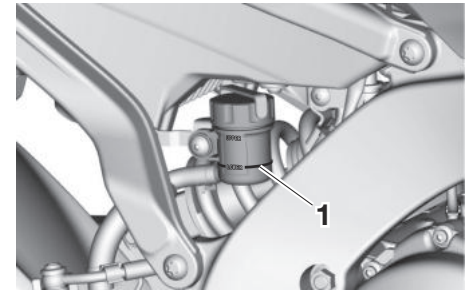

1. Minimum level mark

Specified brake fluid:

YAMAHA GENUINE BRAKE FLUID
(DOT 4)

EWA16011

WARNING

Improper maintenance can result in loss of braking ability. Observe these precautions:

- Insufficient brake fluid may allow air to enter the brake system, reducing braking performance.
- Clean the filler cap before removing. Use only DOT 4 brake fluid from a sealed container.

Periodic maintenance and adjustment

- **Use only the specified brake fluid; otherwise, the rubber seals may deteriorate, causing leakage.**
- **Refill with the same type of brake fluid. Adding a brake fluid other than DOT 4 may result in a harmful chemical reaction.**
- **Be careful that water or dust does not enter the brake fluid reservoir when refilling. Water will significantly lower the boiling point of the fluid and may result in vapor lock, and dirt may clog the ABS hydraulic unit valves.**

fluid level goes down suddenly, have a Yamaha dealer check the cause before further riding.

EAU22734

Changing the brake fluid

Have a Yamaha dealer change the brake fluid every 2 years. In addition, have the seals of the master cylinders and brake calipers, as well as the brake hoses replaced at the intervals listed below or sooner if they are damaged or leaking.

- Brake seals: every 2 years
- Brake hoses: every 4 years

ECA17641

9 **NOTICE**

Brake fluid may damage painted surfaces or plastic parts. Always clean up spilled fluid immediately.

As the brake pads wear, it is normal for the brake fluid level to gradually go down. A low brake fluid level may indicate worn brake pads and/or brake system leakage; therefore, be sure to check the brake pads for wear and the brake system for leakage. If the brake

Periodic maintenance and adjustment

Drive chain slack

EAU22762

The drive chain slack should be checked before each ride and adjusted if necessary.

To check the drive chain slack

EAU45160

1. Place the motorcycle on the side-stand.

TIP

When checking and adjusting the drive chain slack, there should be no weight on the motorcycle.

2. Shift the transmission into the neutral position.
3. Find the center point of the chain (position B) by measuring (approx. 49.0 mm (1.93 in)) forward from the edge of the drive chain guard as shown.

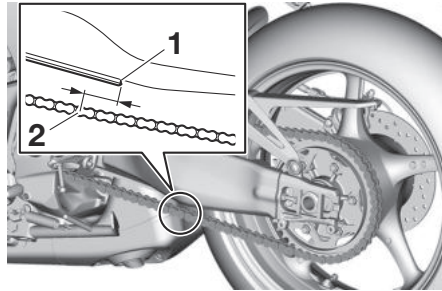

1. Edge of the drive chain guard
2. Position B
4. Push down on the center of the drive chain and measure the distance A from the drive chain guard to the middle of the chain link being pressed down at position B.

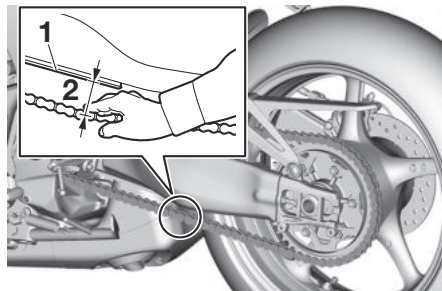

1. Drive chain guard
2. Distance A

Distance A:

35.0–40.0 mm (1.38–1.57 in)

5. If distance A is incorrect, adjust it as follows. **NOTICE: Improper drive chain slack will overload the engine as well as other vital parts of the motorcycle and can lead to chain slippage or breakage. If distance A is more than 45.0 mm (1.77 in), the chain can damage the frame, swingarm, and other parts. To prevent this from occurring, keep the drive chain slack within the specified limits.**^[ECA23070]

To adjust the drive chain slack

EAU74260

Consult a Yamaha dealer before adjusting the drive chain slack.

1. Loosen the axle nut and the lock-nut on each side of the swingarm.

Periodic maintenance and adjustment

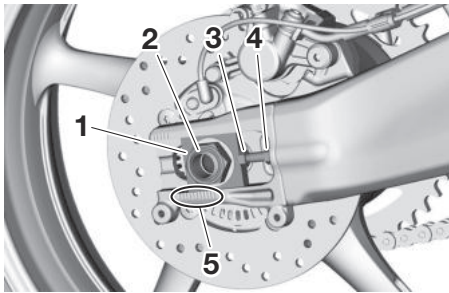

1. Drive chain puller
2. Axle nut
3. Drive chain slack adjusting bolt
4. Locknut
5. Alignment marks

2. To tighten the drive chain, turn the drive chain slack adjusting bolt on each side of the swingarm in direction (a). To loosen the drive chain, turn the adjusting bolt on each side of the swingarm in direction (b), and then push the rear wheel forward.

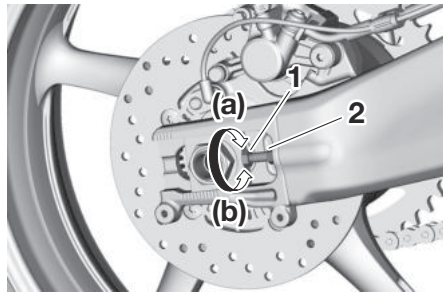

1. Drive chain slack adjusting bolt
2. Locknut

TIP

Using the alignment marks on each side of the swingarm, make sure that both drive chain pullers are in the same position for proper wheel alignment.

3. Tighten the axle nut, then the locknuts to their specified torques.

Tightening torques:

Axle nut:
105 N·m (10.5 kgf·m, 77 lb·ft)
Locknut:
16 N·m (1.6 kgf·m, 12 lb·ft)

4. Make sure that the drive chain pullers are in the same position, the

drive chain slack is correct, and the drive chain moves smoothly.

Cleaning and lubricating the drive chain

EAU23027

The drive chain must be cleaned and lubricated at the intervals specified in the periodic maintenance and lubrication chart, otherwise it will quickly wear out, especially when riding in dusty or wet areas. Service the drive chain as follows.

ECA10584

NOTICE

The drive chain must be lubricated after washing the motorcycle, riding in the rain or riding in wet areas.

1. Clean the drive chain with a drive chain cleaner and a small soft brush. **NOTICE: To prevent damaging the O-rings, do not clean the drive chain with steam cleaners, high-pressure washers or inappropriate solvents.**

[ECA11122]

2. Wipe the drive chain dry.
3. Thoroughly lubricate the drive chain with a special O-ring chain lubricant. **NOTICE: Do not use engine oil or any other lubricants**

for the drive chain, as they may contain substances that could damage the O-rings.[ECA11112]

Checking and lubricating the cables

EAU23098

The operation of all control cables and the condition of the cables should be checked before each ride, and the cables and cable ends should be lubricated if necessary. If a cable is damaged or does not move smoothly, have a Yamaha dealer check or replace it. **WARNING! Damage to the outer housing of cables may result in internal rusting and cause interference with cable movement. Replace damaged cables as soon as possible to prevent unsafe conditions.**[EWA10712]

Recommended lubricant:

Yamaha cable lubricant or other suitable cable lubricant

Periodic maintenance and adjustment

Checking and lubricating the throttle grip

EAU82490

The operation of the throttle grip should be checked before each ride. In addition, the throttle grip housing should be lubricated by a Yamaha dealer at the intervals specified in the periodic maintenance chart.

Checking and lubricating the brake and shift pedals

EAU44276

The operation of the brake and shift pedals should be checked before each ride, and the pedal pivots should be lubricated if necessary.

Brake pedal

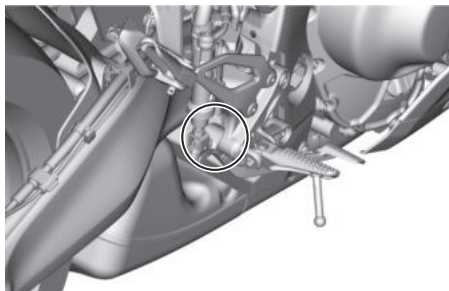

Shift pedal

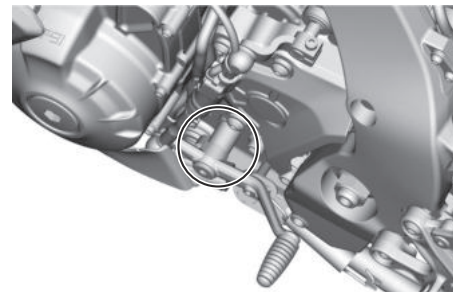

Recommended lubricant:
Lithium-soap-based grease

Periodic maintenance and adjustment

Checking and lubricating the brake and clutch levers

EAU23146

The operation of the brake and clutch levers should be checked before each ride, and the lever pivots should be lubricated if necessary.

Brake lever

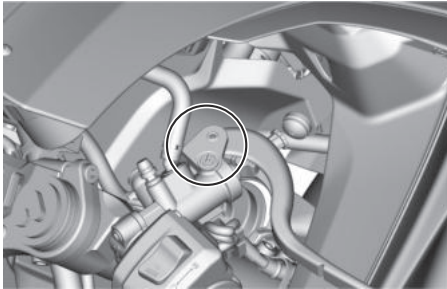

Clutch lever

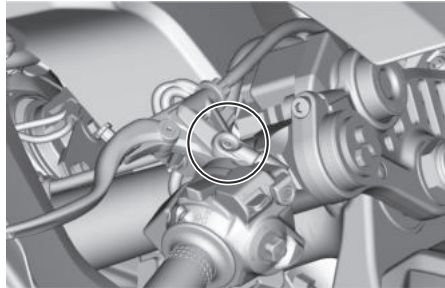

Recommended lubricants:

- Brake lever:
Silicone grease
- Clutch lever:
Lithium-soap-based grease

Checking and lubricating the sidestand

EAU89101

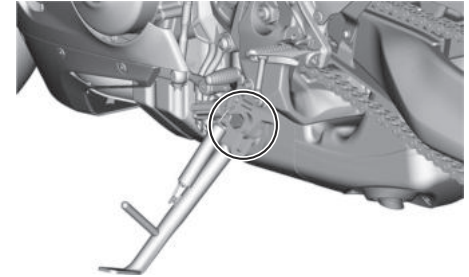

The operation of the sidestand should be checked before each ride, and the sidestand pivot and metal-to-metal contact surfaces should be lubricated if necessary.

EWA10732

WARNING

If the sidestand does not move up and down smoothly, have a Yamaha dealer check or repair it. Otherwise, the sidestand could contact the ground and distract the operator, resulting in a possible loss of control.

- Recommended lubricant:
Molybdenum disulfide grease

Periodic maintenance and adjustment

Lubricating the swingarm pivots

EAM1653

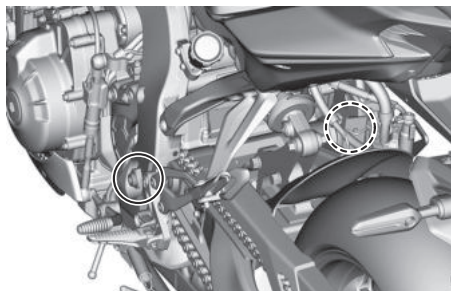

The swingarm pivots must be lubricated by a Yamaha dealer at the intervals specified in the periodic maintenance and lubrication chart.

Recommended lubricant:
Lithium-soap-based grease

Checking the front fork

EAU23273

The condition and operation of the front fork must be checked as follows at the intervals specified in the periodic maintenance and lubrication chart.

To check the condition

Check the inner tubes for scratches, damage and excessive oil leakage.

To check the operation

1. Place the vehicle on a level surface and hold it in an upright position.
WARNING! To avoid injury, securely support the vehicle so there is no danger of it falling over.^[EWA10752]
2. While applying the front brake, push down hard on the handlebars several times to check if the front fork compresses and rebounds smoothly.

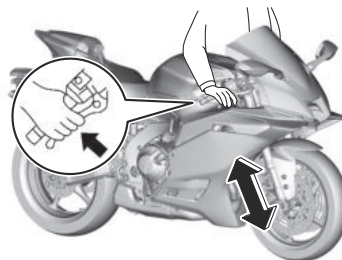

ECA10591

NOTICE

If any damage is found or the front fork does not operate smoothly, have a Yamaha dealer check or repair it.

Checking the steering

EAU23285

Worn or loose steering bearings may cause danger. Therefore, the operation of the steering must be checked as follows at the intervals specified in the periodic maintenance and lubrication chart.

1. Raise the front wheel off the ground. (See page 9-35.)
WARNING! To avoid injury, securely support the vehicle so there is no danger of it falling over.^[EWA10752]
2. Hold the lower ends of the front fork legs and try to move them forward and backward. If any free play can be felt, have a Yamaha dealer check or repair the steering.

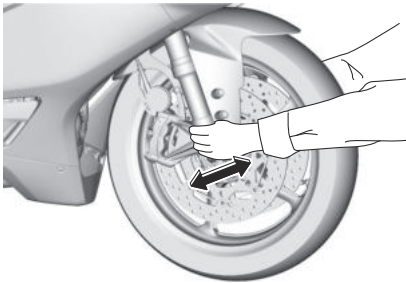

Checking the wheel bearings

EAU23292

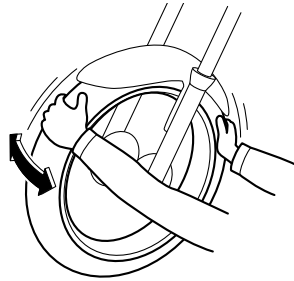

The front and rear wheel bearings must be checked at the intervals specified in the periodic maintenance and lubrication chart. If there is play in the wheel hub or if the wheel does not turn smoothly, have a Yamaha dealer check the wheel bearings.

Battery

EAUJ5810

ECA22960

NOTICE

Use only the specified genuine YAMAHA battery. Using a different battery may cause the IMU to fail and the engine to stall.

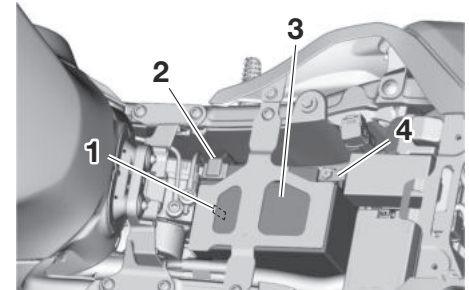

1. Damper
2. Positive battery lead (red)
3. Battery
4. Negative battery lead (black)

The battery is located under the rider seat. (See page 6-47.)

This model is equipped with a VRLA (Valve Regulated Lead Acid) battery. There is no need to check the electrolyte or to add distilled water. However,

Periodic maintenance and adjustment

the battery lead connections need to be checked and, if necessary, tightened.

EWA10761

WARNING

- **Electrolyte is poisonous and dangerous since it contains sulfuric acid, which causes severe burns. Avoid any contact with skin, eyes or clothing and always shield your eyes when working near batteries. In case of contact, administer the following FIRST AID.**
 - **EXTERNAL:** Flush with plenty of water.
 - **INTERNAL:** Drink large quantities of water or milk and immediately call a physician.
 - **EYES:** Flush with water for 15 minutes and seek prompt medical attention.
- **Batteries produce explosive hydrogen gas. Therefore, keep sparks, flames, cigarettes, etc., away from the battery and provide sufficient ventilation when**

charging it in an enclosed space.

- **KEEP THIS AND ALL BATTERIES OUT OF THE REACH OF CHILDREN.**

To charge the battery

Have a Yamaha dealer charge the battery as soon as possible if it seems to have discharged. Keep in mind that the battery tends to discharge more quickly if the vehicle is equipped with optional electrical accessories.

ECA16522

NOTICE

To charge a VRLA (Valve Regulated Lead Acid) battery, a special (constant-voltage) battery charger is required. Using a conventional battery charger will damage the battery.

To store the battery

1. If the vehicle will not be used for more than one month, remove the battery, fully charge it, and then place it in a cool, dry place.
NOTICE: When removing the battery, be sure to turn the main

switch off, then disconnect the negative lead before disconnecting the positive lead.^[ECA16304]

2. If the battery will be stored for more than two months, check it at least once a month and fully charge it if necessary.
3. Fully charge the battery before installation. **NOTICE:** When installing the battery, be sure to turn the main switch off, then connect the positive lead before connecting the negative lead.^[ECA16842]
4. After installation, make sure that the battery leads are properly connected to the battery terminals.

TIP

When installing the battery, take care not to scrape off the damper attached to the inside of the battery box.

ECA16531

NOTICE

Always keep the battery charged. Storing a discharged battery can cause permanent battery damage.

Periodic maintenance and adjustment

Replacing the fuses

EAUJA1844

The fuse box is located under the rider seat. (See page 6-47.)

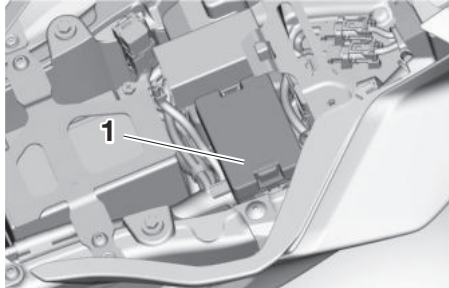

1. Fuse box

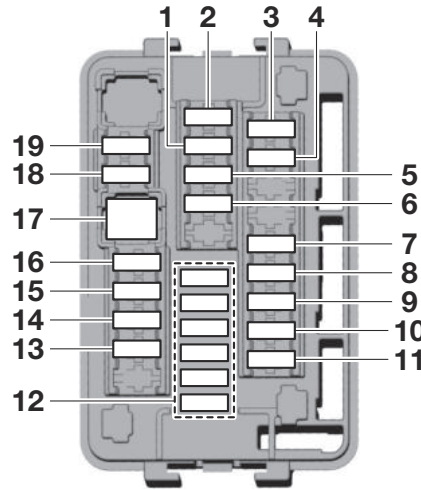

1. Cruise control fuse
2. Brake light fuse
3. Terminal fuse 1
4. Accessory fuse
5. Radiator fan motor fuse
6. Sub radiator fan motor fuse
7. Signaling system fuse
8. Ignition fuse
9. Ignition fuse 2
10. Headlight fuse
11. ABS control unit fuse
12. Spare fuse
13. Electronic throttle valve fuse

14. Fuel injection system fuse
15. Backup fuse 2 (for ECU and immobilizer system)
16. Backup fuse
17. Main fuse
18. ABS motor fuse
19. ABS solenoid fuse

If a fuse is blown, replace it as follows.

TIP

Use a fuse puller to remove the fuse.

1. Turn the main switch off and turn off the electrical circuit in question.
2. Remove the fuse box cover by pressing inwards at the two points indicated on the cover and pulling upwards.

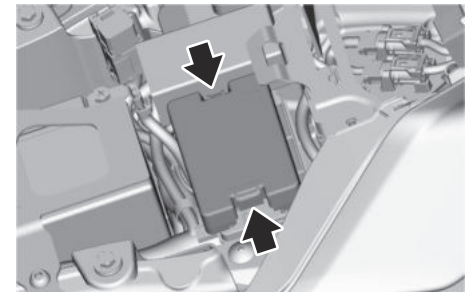

3. Remove the blown fuse using the fuse puller.

Periodic maintenance and adjustment

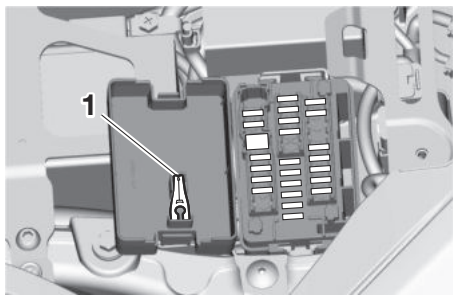

1. Fuse puller

4. Install a new fuse of the specified amperage. **WARNING! Do not use a fuse of a higher amperage rating than recommended to avoid causing extensive damage to the electrical system and possibly a fire.**^[EWA15132]

Specified fuses:

- Main fuse:
50.0 A
- Terminal fuse 1:
5.0 A
- Headlight fuse:
7.5 A
- Brake light fuse:
2.0 A
- Signaling system fuse:
7.5 A
- Ignition fuse:
10.0 A
- Ignition fuse 2:
7.5 A
- Radiator fan motor fuse:
15.0 A
- Sub radiator fan motor fuse:
15.0 A
- ABS motor fuse:
30.0 A
- Fuel injection system fuse:
7.5 A
- ABS solenoid fuse:
15.0 A
- ABS control unit fuse:
7.5 A
- Cruise control fuse:
2.0 A
- Backup fuse:
7.5 A
- Backup fuse 2:
15.0 A

- Electronic throttle valve fuse:
7.5 A
- Accessory fuse:
2.0 A

5. Insert the fuse puller, and then install the fuse box cover.
6. Turn the main switch on and turn on the electrical circuit in question to check if the device operates.
7. If the fuse immediately blows again, have a Yamaha dealer check the electrical system.

ECA27210

NOTICE

Do not drive while the fuse box cover is removed.

Vehicle lights

EAU80381

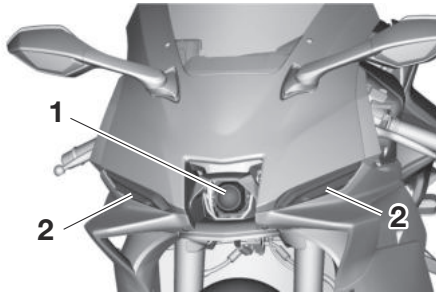

1. Headlight
2. Auxiliary light

Except for the license plate light bulb, this model's lights are all LED. If an LED light does not come on, check the fuses and then have a Yamaha dealer check the vehicle. If the license plate light does not come on, check and replace the bulb. (See page 9-34.)

ECA16581

NOTICE

Do not affix any type of tinted film or stickers to the headlight lens.

Replacing a license plate light bulb

EAU49722

1. Remove the license plate light unit bolts.

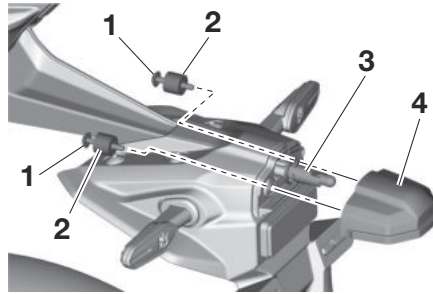

1. Bolt
2. Collar
3. License plate light bulb socket
4. License plate light unit

2. Remove the license plate light bulb socket (together with the bulb) by turning it counterclockwise, and then pulling it out.
3. Remove the burnt-out bulb by pulling it out.

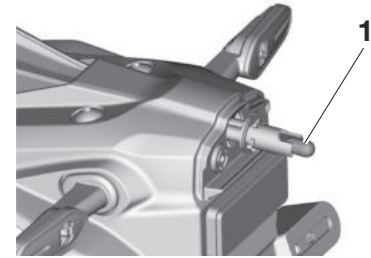

1. License plate light bulb

4. Insert a new bulb into the socket.
5. Install the socket (together with the bulb) by pushing it in, and then turning it clockwise until it stops.
6. Place the license plate light unit in the original position, and then install the bolts.

Periodic maintenance and adjustment

Supporting the motorcycle

EAU67131

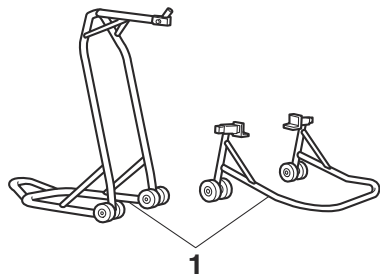

1. Maintenance stand (example)

Since this model is not equipped with a centerstand, use maintenance stands when removing the front or rear wheel or when performing other maintenance that requires the motorcycle to stand up right.

Check that the motorcycle is in a stable and level position before starting any maintenance.

Troubleshooting

EAU25873

Although Yamaha motorcycles receive a thorough inspection before shipment from the factory, trouble may occur during operation. Any problem in the fuel, compression, or ignition systems, for example, can cause poor starting and loss of power.

The following troubleshooting charts represent quick and easy procedures for checking these vital systems yourself. However, should your motorcycle require any repair, take it to a Yamaha dealer, whose skilled technicians have the necessary tools, experience, and know-how to service the motorcycle properly.

Use only genuine Yamaha replacement parts. Imitation parts may look like Yamaha parts, but they are often inferior, have a shorter service life and can lead to expensive repair bills.

EWA15142



WARNING

When checking the fuel system, do not smoke, and make sure there are no open flames or sparks in the area, including pilot lights from water

heaters or furnaces. Gasoline or gasoline vapors can ignite or explode, causing severe injury or property damage.

Troubleshooting chart

1. Fuel

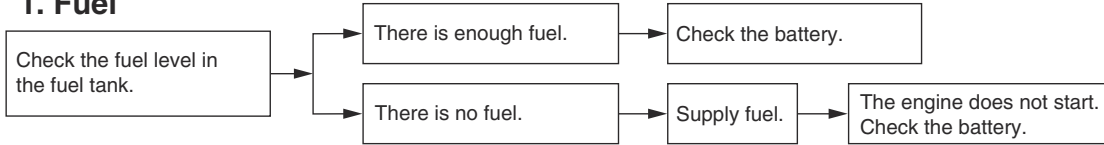

2. Battery

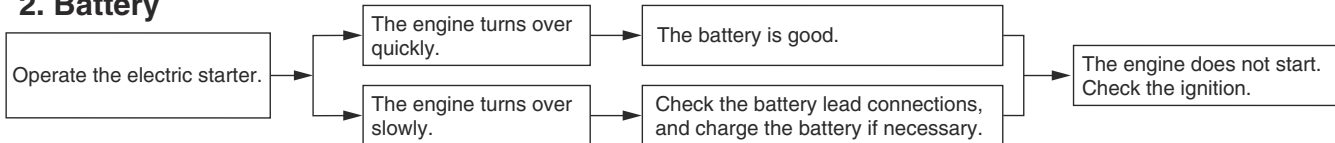

3. Ignition

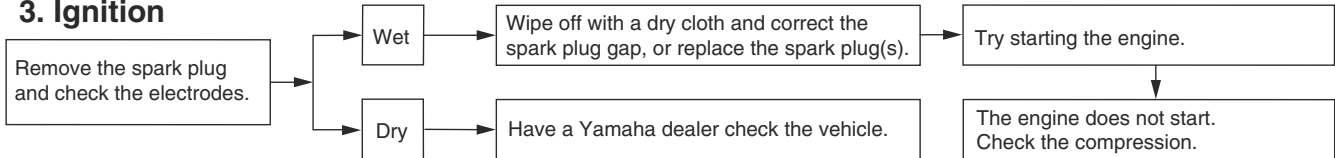

4. Compression

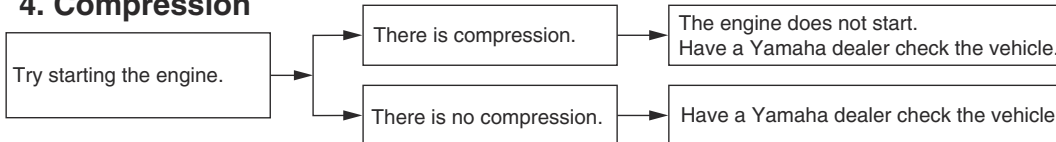

Periodic maintenance and adjustment

EAU86420

Engine overheating

EWAT1041

⚠ WARNING

- Do not remove the radiator cap when the engine and radiator are hot. Scalding hot fluid and steam may be blown out under pressure, which could cause serious injury. Be sure to wait until the engine has cooled.
- Place a thick rag, like a towel, over the radiator cap, and then slowly rotate the cap counterclockwise to the detent to allow any residual pressure to escape. When the hissing sound has stopped, press down on the cap while turning it counterclockwise, and then remove the cap.

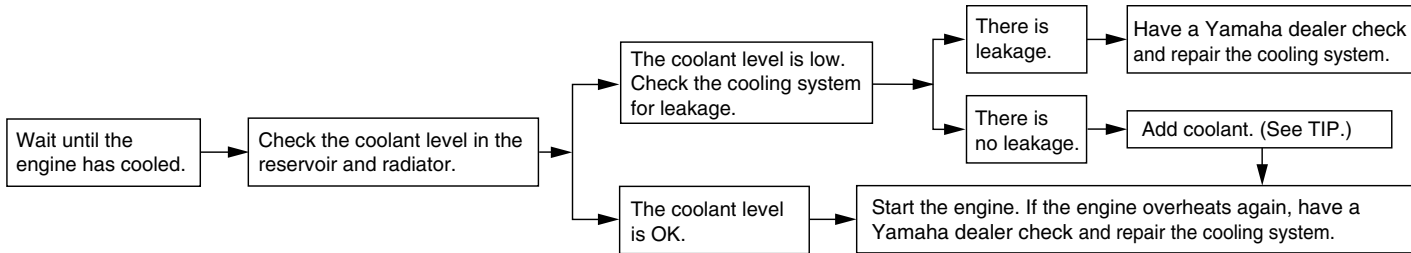

9

TIP

If coolant is not available, tap water can be temporarily used instead, provided that it is changed to the recommended coolant as soon as possible.

Matte color caution

EAU37834

EAU0990

NOTICE

ECA15193

Some models are equipped with matte colored finished parts. Be sure to consult a Yamaha dealer for advice on what products to use before cleaning the vehicle. Using a brush, harsh chemical products or cleaning compounds when cleaning these parts will scratch or damage their surface. Wax also should not be applied to any matte colored finished parts.

Care

Frequent, thorough cleaning of the vehicle will not only enhance its appearance but also will improve its general performance and extend the useful life of many components. Washing, cleaning, and polishing will also give you a chance to inspect the condition of the vehicle more frequently. Be sure to wash the vehicle after riding in the rain or near the sea, because salt is corrosive to metals.

TIP

- Genuine Yamaha care and maintenance products are sold under the YAMALUBE brand in many markets worldwide.
- See your Yamaha dealer for additional cleaning tips.

ECA26280

NOTICE

Improper cleaning can cause cosmetic and mechanical damage. Do not use:

- high-pressure washers or steam-jet cleaners. Excessive water pressure may cause wa-

ter seepage and deterioration of wheel bearings, brakes, transmission seals and electrical devices. Avoid high-pressure detergent applications such as those available in coin-operated car washers.

- harsh chemicals, including strong acidic wheel cleaners, especially on spoke or magnesium wheels.
- harsh chemicals, abrasive cleaning compounds, or wax on matte-finished parts. Brushes can scratch and damage the matte-finish, use soft sponge or towel only.
- towels, sponges, or brushes contaminated with abrasive cleaning products or strong chemicals such as, solvents, gasoline, rust removers, brake fluid, or antifreeze, etc.

Before washing

1. Park the vehicle out of direct sunlight and allow it to cool. This will help avoid water spots.

Motorcycle care and storage

2. Make sure all caps, covers, electrical couplers and connectors are tightly installed.
3. Cover the muffler end with a plastic bag and a strong rubber band.
4. Pre-soak stubborn stains like insects or bird droppings with a wet towel for a few minutes.
5. Remove road grime and oil stains with a quality degreasing agent and a plastic-bristle brush or sponge. **NOTICE: Do not use degreasing agent on areas requiring lubrication such as seals, gaskets, and wheel axles. Follow product instructions.**^[ECA26290]

Washing

1. Rinse off any degreaser and spray down the vehicle with a garden hose. Use only enough pressure to do the job. Avoid spraying water directly into the muffler, instrument panel, air inlet, or other inner areas such as underseat storage compartments.
2. Wash the vehicle with a quality automotive-type detergent mixed with cool water and a soft, clean

towel or sponge. Use an old toothbrush or plastic-bristle brush for hard-to-reach places. **NOTICE: Use cold water if the vehicle has been exposed to salt. Warm water will increase salt's corrosive properties.**^[ECA26301]

3. For windshield-equipped vehicles: Clean the windshield with a soft towel or sponge dampened with water and a pH neutral detergent. If necessary, use a high-quality windshield cleaner or polish for motorcycles. **NOTICE: Never use any strong chemicals to clean the windshield. Additionally, some cleaning compounds for plastic may scratch the windshield, so be sure to test all cleaning products before general application.**^[ECA26310]
4. Rinse off thoroughly with clean water. Be sure to remove all detergent residues, as they can be harmful to plastic parts.

After washing

1. Dry the vehicle with a chamois or absorbent towel, preferably microfiber terrycloth.
2. For drive chain-equipped models: Dry and then lubricate the drive chain to prevent rust.
3. Use a chrome polish to shine chrome, aluminum, and stainless steel parts. Often the thermally induced discoloring of stainless steel exhaust systems can be removed through polishing.
4. Apply a corrosion protection spray on all metal parts including chrome or nickel-plated surfaces. **WARNING! Do not apply silicone or oil spray to seats, hand grips, rubber foot pegs or tire treads. Otherwise these parts will become slippery, which could cause loss of control. Thoroughly clean the surfaces of these parts before operating the vehicle.**^[EWA20651]
5. Treat rubber, vinyl, and unpainted plastic parts with a suitable care product.

Storage

Always store the vehicle in a cool, dry place. If necessary, protect it against dust with a porous cover. Be sure the engine and the exhaust system are cool before covering the vehicle. If the vehicle often sits for weeks at a time between uses, the use of a quality fuel stabilizer is recommended after each fill-up.

NOTICE

- **Storing the vehicle in a poorly ventilated room or covering it with a tarp, while it is still wet, will allow water and humidity to seep in and cause rust.**
- **To prevent corrosion, avoid damp cellars, stables (because of the presence of ammonia) and areas where strong chemicals are stored.**

Long term storage

Before storing the vehicle long term (60 days or more):

6. Touch up minor paint damage caused by stones, etc.
7. Wax all painted surfaces using a non-abrasive wax or use a detail spray for motorcycles.
8. When finished cleaning, start the engine and let it idle for several minutes to help dry any remaining moisture.
9. If the headlight lens has fogged up, start the engine and turn on the headlight to help remove the moisture.
10. Let the vehicle dry completely before storing or covering it.

ECA26320

NOTICE

- **Do not apply wax to rubber or unpainted plastic parts.**
- **Do not use abrasive polishing compounds as they will wear away the paint.**
- **Apply sprays and wax sparingly. Wipe off excess afterwards.**

EWA20660



Contaminants left on the brakes or tires can cause loss of control.

Motorcycle care and storage

1. Make all necessary repairs and perform any outstanding maintenance.
2. Follow all instructions in the Care section of this chapter.
3. Fill up the fuel tank, adding fuel stabilizer according to product instructions. Run the engine for 5 minutes to distribute treated fuel through the fuel system.
4. For vehicles equipped with a fuel cock: Turn the fuel cock lever to the off position.
5. For vehicles with a carburetor: To prevent fuel deposits from building up, drain the fuel in the carburetor float chamber into a clean container. Retighten the drain bolt and pour the fuel back into the fuel tank.
6. Use a quality engine fogging oil according to product instructions to protect internal engine components from corrosion. If engine fogging oil is not available, perform the following steps for each cylinder:
 - a. Remove the spark plug cap and spark plug.
 - b. Pour a teaspoonful of engine oil into the spark plug bore.
 - c. Install the spark plug cap onto the spark plug, and then place the spark plug on the cylinder head so that the electrodes are grounded. (This will limit sparking during the next step.)
 - d. Turn the engine over several times with the starter. (This will coat the cylinder wall with oil.)
WARNING! To prevent damage or injury from sparking, make sure to ground the spark plug electrodes while turning the engine over.
[EWA10952]
 - e. Remove the spark plug cap from the spark plug, and then install the spark plug and the spark plug cap.
7. Lubricate all control cables, pivots, levers and pedals, as well as the sidestand and centerstand (if equipped).
8. Check and correct the tire air pressure, and then lift the vehicle so that all wheels are off the ground. Otherwise, turn the wheels a little once a month in order to prevent the tires from becoming degraded in one spot.
9. Cover the muffler outlet with a plastic bag to prevent moisture from entering it.
10. Remove the battery and fully charge it, or attach a maintenance charger to keep the battery optimally charged. **NOTICE: Confirm that the battery and its charger are compatible. Do not charge a VRLA battery with a conventional charger.**[ECA26330]

TIP

- If the battery will be removed, charge it once a month and store it in a temperate location between 0-30 °C (32-90 °F).
 - See page 9-30 for more information on charging and storing the battery.
-

Dimensions:

- Overall length:
2070 mm (81.5 in)
- Overall width:
705 mm (27.8 in)
- Overall height:
1180 mm (46.5 in)
- Seat height:
830 mm (32.7 in)
- Wheelbase:
1420 mm (55.9 in)
- Ground clearance:
140 mm (5.51 in)
- Minimum turning radius:
3.4 m (11.16 ft)

Weight:

- Curb weight:
195 kg (430 lb)

Engine:

- Combustion cycle:
4-stroke
- Cooling system:
Liquid cooled
- Valve train:
DOHC
- Cylinder arrangement:
Inline
- Number of cylinders:
3-cylinder
- Displacement:
890 cm³
- Bore × stroke:
78.0 × 62.1 mm (3.07 × 2.44 in)

- Starting system:
Electric starter

Engine oil:

- Recommended brand:



- SAE viscosity grades:
10W-40
- Recommended engine oil grade:
API service SG type or higher, JASO standard MA
- Engine oil quantity:
Oil change:
2.80 L (2.96 US qt, 2.46 Imp.qt)
- With oil filter removal:
3.20 L (3.38 US qt, 2.82 Imp.qt)

Coolant quantity:

- Coolant reservoir (up to the maximum level mark):
0.28 L (0.30 US qt, 0.25 Imp.qt)
- Radiator (including all routes):
1.78 L (1.88 US qt, 1.57 Imp.qt)

Fuel:

- Recommended fuel:
Unleaded gasoline (E10 acceptable)
- Octane number (RON):
95
- Fuel tank capacity:
14 L (3.7 US gal, 3.1 Imp.gal)
- Fuel reserve amount:
2.5 L (0.66 US gal, 0.55 Imp.gal)

Fuel injection:

- Throttle body:
ID mark:
BME1

Drivetrain:

- Gear ratio:
1st:
2.571 (36/14)
- 2nd:
1.947 (37/19)
- 3rd:
1.619 (34/21)
- 4th:
1.381 (29/21)
- 5th:
1.190 (25/21)
- 6th:
1.037 (28/27)

Front tire:

- Type:
Tubeless
- Size:
120/70ZR17M/C(58W)
- Manufacturer/model:
BRIDGESTONE/BATTLAX RACING STREET RS11F

Rear tire:

- Type:
Tubeless
- Size:
180/55ZR17M/C(73W)
- Manufacturer/model:
BRIDGESTONE/BATTLAX RACING STREET RS11R

Specifications

Loading:

Maximum load:

164 kg (363 lb)

(Total weight of rider, passenger, cargo and accessories)

Auxiliary light:

LED

License plate light:

5.0 W

Front brake:

Type:

Hydraulic dual disc brake

Rear brake:

Type:

Hydraulic single disc brake

Front suspension:

Type:

Telescopic fork

Rear suspension:

Type:

Swingarm (link suspension)

Electrical system:

System voltage:

12 V

Battery:

Model:

YTZ10S

Voltage, capacity:

12 V, 8.6 Ah (10 HR)

Bulb wattage:

Headlight:

LED

Brake/tail light:

LED

Front turn signal light:

LED

Rear turn signal light:

LED

Identification numbers

Record the vehicle identification number, engine serial number, and the model label information in the spaces provided below. These identification numbers are needed when registering the vehicle with the authorities in your area and when ordering spare parts from a Yamaha dealer.

VEHICLE IDENTIFICATION NUMBER:

ENGINE SERIAL NUMBER:

MODEL LABEL INFORMATION:

EAU53562

Vehicle identification number

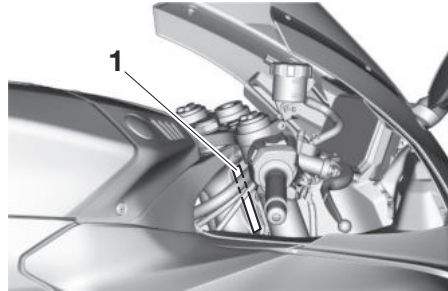

1. Vehicle identification number

The vehicle identification number is stamped into the steering head pipe. Record this number in the space provided.

TIP

The vehicle identification number is used to identify your motorcycle and may be used to register your motorcycle with the licensing authority in your area.

EAU26401

Engine serial number

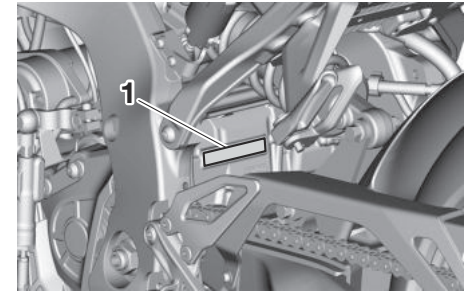

1. Engine serial number

The engine serial number is stamped into the crankcase.

EAU26442

Model label

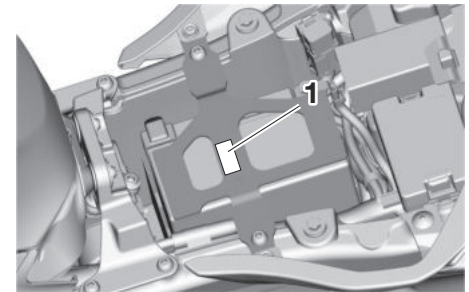

1. Model label

EAU5150

Consumer information

The model label is affixed to the battery plate under the rider seat. (See page 6-47.) Record the information on this label in the space provided. This information will be needed when ordering spare parts from a Yamaha dealer.

EAU69910

Diagnostic connector

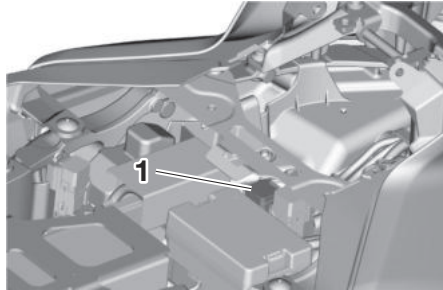

1. Diagnostic connector

The diagnostic connector is located as shown.

Use of your data

This is a brief summary of how Yamaha (Yamaha Motor Co., Ltd., and the local subsidiaries) uses your data. For more details for Yamaha's use of your data, please see our Privacy Policy.

<https://global.yamaha-motor.com/en/privacy/>

What data we collect? and How we collect your data?

This vehicle collects three types of data through integrated Engine Control Units (ECU).:

(1) Vehicle Identification Number (VIN); (2) live data showing the performance of the vehicle such as engine/motor operating state, vehicle speed, mileage; and (3) other data showing the status of the vehicle such as diagnostic trouble code (DTC).

The collected data will be uploaded to server at Yamaha Motor Co., Ltd. by attaching a special Yamaha diagnostic tool to the vehicle, only when maintenance checks or service procedures are performed.

How will we use your data?

Yamaha use collected data from your vehicle, (1) to conduct adequate maintenance service including diagnostics, (2) to implement proper warranty claim judgement, (3) to conduct research and development of vehicle, (4) to provide and improve quality of products, features, and services, (5) to ensure our business purpose, and (6) to comply with legal obligations or lawful orders, and to establish or defend legal claims.

How we share your data?

We may share your data with: (i) our subsidiaries, affiliates, and business partners; (ii) dealers and distributors in your country or region, and (iii) contractors within the scope necessary to achieve the purpose of use described above.

How to contact us

Any questions or complaints regarding the processing of your Personal Data can be submitted in writing to the local subsidiaries.

<https://global.yamaha-motor.com/link/>

The SOLE PURPOSE of above provided contact information is TO RESPOND DATA PROCESSING INQUIRY AND OTHER KINDS OF INQUIRIES WILL NOT BE RESPONDED. Please provide the following information for the proper

Consumer information

handling of your inquiry: **(1) Your Name; (2) Your Email Address; (3) Your Country of Residence; and (4) Your VIN.** We will use your personal information provided only for the purpose of supporting your data processing inquiry.

- A**
- ABS warning light..... 6-6
 - Air filter element..... 9-16
 - Anti-lock brake system (ABS)..... 6-43
- B**
- Battery..... 9-30
 - BC (Brake control system)..... 4-4
 - Brake and clutch levers, checking and lubricating..... 9-28
 - Brake and shift pedals, checking and lubricating..... 9-27
 - Brake fluid level, checking..... 9-22
 - Brake fluid, changing..... 9-23
 - Brake lever..... 6-42
 - Brake lever free play, checking..... 9-20
 - Brake light switches..... 9-21
 - Brake pedal..... 6-43
 - Brake system..... 6-43
 - BSR (Back slip regulator)..... 4-4
- C**
- Cables, checking and lubricating..... 9-26
 - Canister..... 9-11
 - Care..... 10-1
 - Catalytic converter..... 6-47
 - Clutch lever..... 6-41
 - Clutch lever free play, adjusting..... 9-19
 - Connection troubleshooting..... 5-8
 - Coolant..... 9-14
 - Cowlings, removing and installing..... 9-8
 - Cruise control system..... 4-6
 - Cruise control/YVSL switches..... 6-5
- D**
- DC connectors..... 6-55
 - Diagnostic connector..... 12-2
- Dimmer/Pass switch..... 6-3
- Display..... 6-8
- Display, menu system..... 6-21
- Drive chain slack..... 9-24
- Drive chain, cleaning and lubricating..... 9-26
- E**
- EBM (Engine brake management)..... 4-3
 - Engine break-in..... 8-1
 - Engine idling speed, checking..... 9-16
 - Engine oil..... 9-11
 - Engine operation switch..... 6-4
 - Engine overheating..... 9-37
 - Engine serial number..... 12-1
 - Engine trouble warning light..... 6-6
 - ESS (emergency stop signaling) system..... 4-11
- F**
- Front and rear brake pads, checking..... 9-21
 - Front fork, adjusting..... 6-50
 - Front fork, checking..... 9-29
 - Fuel..... 6-45
 - Fuel consumption, tips for reducing..... 8-5
 - Fuel tank cap..... 6-44
 - Fuel tank overflow hose..... 6-46
 - Fuses, replacing..... 9-32
- H**
- Handlebar switches..... 6-3
 - Hazard switch..... 6-4
 - Helmets..... 2-5
 - High beam indicator light..... 6-6
 - Horn switch..... 6-4
- I**
- Identification numbers..... 12-1
 - Ignition circuit cut-off system..... 6-57
 - Immobilizer system..... 6-1
- Immobilizer system indicator light..... 6-6
- Indicator lights and warning lights..... 6-5
- J**
- Joystick and home button..... 6-5
- L**
- Labels, location..... 1-1
 - LCS (Launch control system)..... 4-5
 - License plate light bulb, replacing..... 9-34
 - LIF (Lift control system)..... 4-3
- M**
- Main switch/steering lock..... 6-2
 - Maintenance and lubrication, periodic..... 9-4
 - Maintenance, emission control system..... 9-3
 - Matte color, caution..... 10-1
 - Menu system controls..... 5-1
 - Model label..... 12-1
- N**
- Navigation system: Garmin StreetCross..... 5-5
 - Neutral indicator light..... 6-6
- P**
- Parking..... 8-5
 - Part locations..... 3-1
 - PWR (Power delivery mode)..... 4-1
- Q**
- QS (Quick shifter)..... 4-3
- R**
- Rear view mirrors..... 6-50
 - Rider footrest position, adjusting..... 6-49
- S**
- Safety information..... 2-1
 - SC (Stability control system)..... 4-1
 - SCS (Slide control system)..... 4-2
 - Seats..... 6-47
 - Shift indicator light..... 6-6

Index

Shift pedal..... 6-42
Shifting..... 8-3
Shock absorber assembly, adjusting..... 6-53
Sidestand..... 6-57
Sidestand, checking and lubricating..... 9-28
Smart features initial setup..... 5-3
Smart features: Introduction..... 5-1
Spark plugs, checking..... 9-10
Special features..... 4-1
Specifications..... 11-1
Stability control indicator light..... 6-7
Starting the engine..... 8-2
Steering, checking..... 9-30
Storage..... 10-3
Storage compartment..... 6-49
Supporting the motorcycle..... 9-35
Swingarm pivots, lubricating..... 9-29

T

TCS (Traction control system)..... 4-2
Telephone..... 5-7
Throttle grip, checking and lubricating..... 9-27
Tires..... 9-17
Tool kit..... 9-2
Troubleshooting..... 9-35
Troubleshooting chart..... 9-36
Turn signal indicator lights..... 6-6
Turn signal switch..... 6-4

U

USB Type-C jack..... 6-56
Use, your vehicle data..... 12-3

V

Valve clearance..... 9-16
Vehicle identification number..... 12-1
Vehicle lights..... 9-34

W

Wheel bearings, checking..... 9-30
Wheels..... 9-19

Y

Y-TRAC Rev app..... 5-2
Yamaha Motorcycle Connect app..... 5-2
Yamalube..... 9-14
YRC (Yamaha Ride Control)..... 4-1
YRC mode switch..... 6-5
YVSL..... 4-9



PRINTED IN JAPAN
2025.12-0.3×1 CR (E)